



McCROMETER, INC.'S STANDARD TERMS AND CONDITIONS OF PURCHASE

Rev. 1.2, November 14, 2022

1. CONTRACT FORMATION

1.A. ACCEPTANCE - ENTIRE AGREEMENT - MODIFICATION

1.A.1 This order (hereinafter "order") is for the purchase and sale of Goods and services described on the face of this order (hereinafter "Goods") issued by McCrometer, Inc. (hereinafter "Buyer"). Acceptance of this order will be limited to the terms and conditions contained herein and incorporated herein by reference. This order will be deemed accepted upon the return of the acknowledgment copy of this order or the commencement of performance by Seller. Buyer rejects any additional or inconsistent terms and conditions offered by Seller at any time, whether or not such terms or conditions materially alter the order and irrespective of Buyer's acceptance of or payment for Seller's Goods or services. Any reference to Seller's quotation, bid or proposal does not imply acceptance of any term, condition, or instruction contained in such document. Trade custom and/or trade usage is superseded by this order and will not be applied in the interpretation of this order.

1.A.2 These terms and conditions together with the specifications, drawings, or other documents referred to on the face of the order or incorporated by reference to the part number of the Goods and which form the basis for the specifications, designs and/or quality requirements of the Goods constitute the entire agreement between the parties and no change to or modification of this order will be binding upon Buyer unless in writing and signed by an authorized representative of Buyer. In the event of any ambiguities, express conflicts or discrepancies in the specifications, drawings, or other documents which are a part of this order, Seller will immediately submit the matter to Buyer for its determination and will comply with the determination of Buyer in such matter.

2. CONTRACT PERFORMANCE

2.A. MATERIAL, EQUIPMENT, TOOLS AND FACILITIES

2.A.1 Title to property furnished to Buyer by Seller or paid for by Buyer under this order, including without limitation drawings, patterns, tools, dies and any other Goods made in support of this order, as well as any replacements thereof, (all hereinafter referred to as "Property") will be vested in Buyer with the right to demand possession at any time. Seller will physically identify and mark the Property as Buyer's Property. Seller will use said Property only in the performance of work for Buyer. Seller will bear the risk of loss of all Property while in Seller's custody or control and while in the custody or control of Seller's suppliers. All Property is subject to removal and return at Buyer's written request, in which event Seller, at Buyer's expense, will prepare such Property for shipment and deliver them to Buyer in the same condition as originally received by Seller, reasonable wear and tear excepted.

2.A.2 Seller will maintain all Property in good condition and repair or replace them to the extent necessary for performance of this order. Seller will establish and maintain a system to control, protect, preserve and maintain all Property. Buyer will have the right to enter Seller's premises at all reasonable times to inspect Property and Seller's records with respect thereto. Buyer does not warrant any aspect of the Property that it furnishes and all Goods delivered by Seller must be in strict accordance with the requirements of this order. Upon completion or termination of this order, Seller will retain all Property at

Copyright © 2022 McCrometer, Inc. All printed material should not be changed or altered without permission of McCrometer. Any published technical data, instructions and Terms And Conditions are subject to change without notice. Contact your McCrometer representative for current content.

3255 WEST STETSON AVENUE • HEMET, CALIFORNIA 92545 USA

TEL: 951-652-6811 • 800-220-2279 • FAX: 951-652-3078

www.mccrometer.com

Page 1 of 20

30124-99 Rev. 1.2 | 14NOV2022

its expense until disposition directions are received from Buyer. Seller will pay personal property taxes on all Goods in its possession. Manufacturing location and processing may not be changed without Buyer's written consent.

2.B. DELIVERIES AND SHIPMENTS

2.B.1 Unless otherwise specified on the face of the order, Goods must be shipped Incoterms delivered duty paid. Itemized packing lists will accompany each shipment. Buyer's count will be accepted as final and conclusive on shipments not accompanied by Seller's itemized packing list. No charge will be allowed for packing, shipment, or handling unless otherwise stated in the order. Delivery of the Goods and related data and/or documentation and/or performance of required services in accordance with the schedule are a material requirement of this order. TIME IS OF THE ESSENCE. Seller will not, without Buyer's prior written consent, manufacture or procure materials in advance of Seller's reasonable flow time. Seller will promptly notify Buyer of any actual or anticipated delay of delivery and take all reasonable steps to avoid or end delay without additional cost to Buyer. Seller will, at its expense, ship by express or air shipment or by the most expeditious way if the delivery schedule is endangered for any reason other than Buyer's fault. Buyer reserves the right to reject all or any part of any delivery that varies from the quantity authorized by Buyer for shipment.

2.B.2 IMPORTANT: All Goods must be packaged in accordance with Buyer's instructions or, if none are specified, in accordance with good commercial practice in a manner sufficient to ensure arrival in an undamaged condition. (See Attachment A contained herein.) If any Goods are not packaged/loaded in accordance with Attachment A, the Goods will not be unloaded at the McCrometer site, and will be returned to the Seller at Seller's expense. Goods shipped in advance of Buyer's delivery schedule may be returned or stored at Seller's expense. Seller will give notice of shipment to Buyer at the time of delivery of any shipment of Goods to a carrier for transportation. Title and risk of loss to Goods pass to Buyer Incoterms delivered duty paid unless otherwise specified on the face of this order. Notwithstanding the foregoing, title and risk of loss to Goods subject to a consignment stock agreement pass upon release of the Goods from the consignment stock.

2.C. LIQUIDATED DAMAGES

Supplier agrees that if it exceeds the scheduled delivery date set forth on the purchase order, McCrometer shall be entitled to liquidated damages according to the following schedule: 0.5% of the Purchase Order Value for each complete week of delay up to a maximum of 10% of the value of the delayed Goods from the agreed delivery date, with no grace period.

3. INSPECTION

3.A. INSPECTION OF GOODS BY BUYER

3.A.1 Notwithstanding (i) payment, (ii) passage of title, or (iii) prior inspection or test, all Goods are subject to final inspection and acceptance or rejection by Buyer at Buyer's facility. At all reasonable times, including the period of manufacture, Buyer, its representatives, its customers, and/or representatives of applicable regulatory agencies may inspect and/or test the Goods to be furnished hereunder at the places where the work is being performed, including those of the Seller's suppliers, and Seller will provide, without additional charge, reasonable facilities and assistance for safe and convenient inspection and test. Buyer may inspect 100% or a sample of all Goods or any lot of Goods at Buyer's option, and Buyer has the right to reject all or any portion of the Goods or lot of Goods if any such inspection reveals them to be, in Buyer's sole opinion, defective or nonconforming. Seller will provide and maintain a quality control, test and inspection system acceptable to Buyer and its customers, if required. Seller will keep complete records of all inspection work and will make them available to Buyer and its customers during

the performance hereof and for ten (10) years after final payment by Buyer. Buyer is not required to inspect Goods delivered, and no inspection or failure to inspect will reduce or alter Seller's obligations under this order. Seller is responsible for the performance of all activities affecting the Goods quality and delivery, including those of its sub-suppliers.

4. WARRANTY

4.A. NON-CONFORMING GOODS

4.A.1 Seller warrants to Buyer, its successors and customers that all Goods furnished (including all replacement Goods and all replacement or corrected components which Seller furnishes pursuant to this warranty) will be free from defects in material and workmanship for a period of thirty six (36) months from the date of delivery to the retail purchaser or such longer period of time as may have been accepted by Buyer from Buyer's customer or as required by applicable regulations or law. Further, all Goods furnished will conform to applicable drawings, designs, quality control plans, specifications and samples and other descriptions furnished or specified by Buyer and, to the extent such Goods are not of a detailed design furnished by Buyer, will be merchantable, suitable for the intended purposes and free from all other defects, including defects in design. To the extent this order calls for services to be performed, such services will be free from defects in workmanship, will meet all of the requirements of this order and will be performed to the highest standards of workmanship in the industry. All of the preceding are hereinafter collectively called "conforming products and/or services."

4.A.2 In the event conforming products and/or services are not furnished, within twenty four (24) hours after the nonconforming product is returned to Seller or notice to Seller of a nonconforming service is received or such longer period as may be commercially reasonable under the circumstances, Seller will correct nonconforming products and/or correct such nonconforming services. The failure of Seller to repair or replace and redeliver such nonconforming products and/or to correct such nonconforming services within such period entitles Buyer, at its election and in addition to any other rights or remedies it may have at law or in equity, to have such nonconforming products repaired or replaced or such nonconforming services corrected at Seller's expense. In addition to the costs of repairing or replacing such nonconforming products and/or correcting such nonconforming services, Seller is responsible for all related costs including, but not limited to, the costs of removal, disassembly, failure analysis, fault isolation, reinstallation, re-inspection and retrofit of the nonconforming products or services or of Buyer's affected end-product; all freight charges; all customer charges; and all corrective action costs (i.e. costs of additional inspection or quality control systems). Unless set-off by Buyer, Seller will reimburse Buyer for all such costs within thirty (30) days of receipt of Buyer's invoice.

4.A.3 Seller warrants full and unrestricted title to Buyer for the Goods furnished by Seller under this order, free and clear of any and all liens, restrictions, reservations, security interests or encumbrances.

5. CONTRACT PERFORMANCE REVISIONS

5.A. CHANGES

5.A.1 Buyer may, at any time, by written order, to include emails and/or a revised purchase order, change order, without notice to any sureties, make changes in any one or more of the following: (i) drawings, designs, specifications, where the Goods to be furnished are to be specially manufactured for the Buyer in accordance therewith; (ii) method of shipment or packing; (iii) place or time of inspection, delivery, or acceptance; (iv) the quantity and/or type of services ordered, (v) the work or service schedules, and (vi) the amount of any Buyer furnished property. If Seller believes that any such change affects the price or delivery for such Goods or services, then Seller will so notify Buyer in writing, with

adequate supporting documentation, within ten (10) calendar days after receipt of such direction. Buyer and Seller will mutually agree, in writing, upon an equitable adjustment in the price and/or delivery date to reflect the effect of such change within ten (10) calendar days of Seller's notification. If Buyer and Seller are unable to agree on the adjustment, Buyer will make a good faith adjustment which will be binding on Seller. Seller's request for any adjustments will be deemed waived unless submitted in writing within such ten (10) calendar days after Seller receives direction to make such changes. If Seller considers that the conduct, statement or direction of any of Buyer's employees constitutes a change hereunder, Seller will notify Buyer and take no action on the perceived change pending written approval of Buyer. Only Buyer has authority to approve a change. Any change made by Seller without such written approval will be deemed voluntary by Seller and not compensable in the cost of or time required for performance. Nothing in this Article excuses Seller from proceeding with performance of this order as changed including the parties' failure to agree on the equitable adjustment. Notwithstanding the above or any other provision of this order, the Seller hereby agrees that no changes to the Goods that may be required in order to meet the specified performance requirements of this order entitle the Seller to any adjustment in either price or delivery.

5.B. DESIGN CHANGES

5.B.1 During performance of this order, Seller will not make any changes in the design of Goods to be furnished or the manufacturing processes by Seller under this order without advance written notification to and written approval of the Buyer. The above requirement applies whether or not there is a cost impact associated with the change and regardless of the type of change involved, including product improvements.

5.C. STOP WORK ORDERS

5.C.1 Buyer may, at any time by written order, require Seller to stop all or any part of the work under this order for a period of up to one hundred eighty (180) days. Immediately upon receipt of such stop work order, Seller shall comply with its terms and take all reasonable steps to minimize the incurrence of costs allocable to the work stoppage. At any time during such period, Buyer may, in whole or in part, either cancel the stop work order or terminate the work in accordance with subparagraph A or B of the "Cancellation" Article of this order (see Article 9, below). To the extent the stop work order is canceled or expires, Seller shall resume work. If a stop work order is the sole and exclusive cause of a material change in cost or delivery, an adjustment shall be made in the price (excluding profit) or the delivery schedule, or both and this order modified accordingly; provided, however, that no adjustment in price or delivery shall be made under this Article if, (i) the work would have been otherwise interrupted or delayed, or (ii) such adjustment is available or expressly excluded under any other provision of this order. No claim for adjustment shall be allowed unless submitted to Buyer in writing in a specified amount within twenty (20) days after the work is terminated or the stop work order expires or is canceled, whichever first occurs. In no event shall Seller be entitled to any loss of prospective profits, contributions to overhead, or any incidental, consequential or other damages because of such suspension or withdrawal of suspension.

5.D. CANCELLATION

5.D.1 Buyer reserves the right to cancel this order in whole or, from time to time, in part for Seller's default (i) if Seller fails or refuses to perform in accordance with any of the requirements of this order or to make progress so as to endanger performance hereunder, or (ii) if Seller becomes insolvent or suspends any of its operations or if any petition is filed or proceeding commenced by or against Seller under any state, Federal, or other jurisdiction's law relating to bankruptcy, arrangement, reorganization, receivership or assignment for the benefit of creditors, or if Seller fails to pay any sums owed to any government agency or landlord when due, or if Seller's credit rating drops by more than one class based

on the rating of any generally recognized credit rating agency. Any such cancellation will be without liability to Buyer except for completed Goods delivered and accepted by Buyer, payment for which can be set off against damages to Buyer. Buyer may require Seller to transfer title and deliver to Buyer any or all property produced or procured by Seller for performance of the work canceled and Seller will be credited with the reasonable value thereof not to exceed Seller's cost or the contract price, whichever is less. Seller will be liable for damages caused by or resulting from its default including but not limited to excess costs of re-procurement. If, after a default cancellation, it is determined that Seller was not in default, the cancellation will be considered to have been made pursuant to subparagraph B of this Article. Buyer or its designee will have the right to audit all elements of any termination claim and Seller will make available to Buyer or Buyer's designee on request all books, records, and papers relating thereto. Cancellation of the order for default will be without prejudice to any other rights and remedies of the Buyer under applicable law.

5.D.2 Buyer may cancel this order in whole or in part at any time by written notice stating the extent and effective date of such cancellation if Buyer's customer stops purchasing from Buyer for any reason, or if Seller is no longer competitive in price, quality, delivery, or other service(s). Upon receipt, Seller will to the extent directed by Buyer (i) stop work under this order and place no further orders hereunder, (ii) cancel work under outstanding orders which relate to work canceled by such notice, and (iii) preserve and protect property in Seller's possession in which Buyer has or may acquire an interest. Seller will submit to Buyer a written claim, if any, as soon as possible, but in any event not later than thirty (30) days from the effective date of cancellation. Seller gives Buyer the right to audit and inspect its books, records and other papers relating to its cancellation claim. If the parties cannot agree within a reasonable time upon the amount of fair compensation for such cancellation, Buyer's liability to Seller will be limited to making prompt payment of the following amounts only without duplication: (a) the contract price, not previously paid, for Goods delivered or performed and accepted by Buyer, or completed in accordance with the provisions of this order prior to the effective date of cancellation and (b) the actual costs incurred by Seller for work in process or other physical inventory, subject to the restrictions on advance manufacture or procurement set forth in Article 3, the cost of which is properly allocable to the canceled portion of this order. Seller may, with Buyer's written consent, retain at an agreed price or sell at an approved price any such completed items or any Goods, work in process or other physical inventory. Buyer will credit or pay the amounts so agreed or received with appropriate adjustment for delivery cost savings. Seller will, if directed by Buyer, transfer title to and make delivery of any such Goods, work in process or other physical inventory not so retained or sold, with all applicable warranties. In no event will Buyer be liable for capital equipment expenditures, overhead, research and development costs, labor-related costs or other similar costs or expenditures.

5.D.3 To the extent this order is not canceled pursuant to subparagraphs A or B above, Seller will continue performance.

6. EXCUSABLE DELAYS

6.A. BEYOND CONTROL OF SELLER OR SUPPLIER

6.A.1 Neither party will be in default for any delay or failure to perform hereunder due to causes beyond its control and without its fault or negligence; provided, that any delay or failure to perform caused by the default of a supplier of the Seller at any lower-tier will be excused only if it is beyond the control of both Seller and such supplier and without the fault or negligence of either and the Goods to be furnished are not obtainable from other sources in sufficient time to permit Seller to meet the delivery schedule; and provided further, that Seller furnishes prompt written notice to Buyer of the occurrence of any such cause that will or may delay Seller's performance. If delivery of any item is delayed by any

excusable delay for more than three (3) months, Buyer may, without any additional extension, cancel all or part of any order with respect to the delayed product, and exercise any of its remedies in accordance with Article 9.A., provided, however, that the Buyer will not be entitled to monetary damages or specific performance where Seller's breach is the result of an Excusable Delay.

7. PRICING AND PAYMENT TERMS

7.A. PRICES, TAXES AND NEW MATERIAL

7.A.1 Seller warrants that none of the Goods furnished under this order are surplus, used, remanufactured or reconditioned or of such age or so deteriorated as to impair the usefulness or safety thereof, unless otherwise specifically stated on the face of this order. Seller warrants that each price for Goods sold to Buyer under this order is no less favorable than that extended during the term of this order to any other customer for the same or like Goods in equal or less quantities on similar terms and conditions. Unless otherwise provided on the face of this order, the prices appearing herein include all packaging, crating and federal, state and local taxes, if applicable, and are firm for the delivery or "valid to" period shown.

7.B. PAYMENT TERMS

7.B.1 Payment periods and cash discount periods will be computed from either the date of delivery or acceptance of the Goods ordered or the date of receipt of correct and proper invoices prepared in accordance with the terms of the order or the date Buyer takes title if the Goods are consigned, whichever is later. The payment date will be delayed on a day-for-day basis for any item that is delivered later than called for by Buyer's schedule. Unless otherwise stated on the face of this order, payment terms are NET 90 Days.

7.C. SETOFF

7.C.1 Buyer may set-off any amount due from Seller, or its affiliates, to Buyer or its affiliates, whether or not under this order, from any amounts due to Seller or its affiliates under this order.

7.D. LIENS

7.D.1 Final payment to Seller operates as a release of any and all claims, actions, and liens against the Buyer on account of the order and Seller agrees to save harmless the Buyer from future claims, actions, and liens. Application for final payment must be accompanied by Waivers and Releases of Liens for all subcontractors, if required by Buyer.

7.E. FUNDS TRANSFERS (PAYMENTS)

7.E.1 Seller and McCrometer both recognize that there is a risk of banking fraud when individuals impersonating a business demand payment under new banking or mailing instructions. To avoid this risk, Seller must verbally confirm any new or changed bank transfer or mailing instructions by calling McCrometer at +1-951-652-6811 and speaking with McCrometer's Credit Manager before the mailing or transferring any monies using the new instructions. Both parties agree that they will not institute mailing or bank transfer instruction changes and require immediate payment under the new instructions but will instead provide a ten (10) day grace period to verify any payment instruction changes before any new or outstanding payments are due using the new instructions.

8. DESIGN, OWNERSHIP, INDEMNITY

8.A. DESIGNS, DRAWINGS AND DATA

8.A.1 This provision governs information (including, but not limited to, technical or commercial information, hardware, software, designs, drawings, data, tooling, processes, systems or methods), written, oral or otherwise, that (i) has been made available to Seller by or on behalf of Buyer; or (ii) Seller has designed at Buyer's expense; or (iii) Seller has designed specifically to meet Buyer-furnished requirements (hereinafter designated "Information"). Seller, in consideration of Buyer's furnishing of such Information and/or funding, agrees that it will not use, or assist others in using such Information, or disclose such Information to anyone, or sell any Goods incorporating such Information to anyone other than Buyer, either as production, spare or repaired Goods, without Buyer's prior written consent, except in the performance of orders for Buyer. Upon Buyer's request, Seller will return to Buyer such Information and all copies thereof, or confirm deletion or destruction. If Seller develops, or sells the Goods hereunder, or assists others in doing so, (or similar interchangeable or substitute Goods, or parts thereof) to anyone other than Buyer, Seller bears the burden to establish that Buyer's Information was not used.

8.A.2 The copyright including the right to copy, distribute, sell, use for commercial purposes, translate, and make derivative works. Information prepared by Seller specifically in connection with performance of this order, including original works of authorship created by Seller, is automatically transferred from Seller to Buyer. Buyer is deemed the author of such works. If any such work is determined by a court of competent jurisdiction not to be a work made for hire, this agreement operates as an irrevocable assignment by the author of such work to Buyer, of the copyright in the work, including all right, title and interest throughout the world.

8.A.3 Where such Information is furnished to Seller's suppliers for use in performance of Buyer's orders, Seller will insert the substance of this Article 16 in all such orders to Seller's suppliers and subcontractors.

8.B. PATENT, TRADEMARK AND COPYRIGHT INDEMNITY

8.B.1 Seller indemnifies and holds harmless Buyer from any and all damages, costs, including legal fees, losses, and liabilities resulting from a suit or proceeding from infringement of any patent, trademark or copyright by reason of the sale or use of any item sold to Buyer hereunder, and from reasonable expenses incurred by Buyer in defense of such suit or proceeding to the extent Seller does not undertake the defense thereof; provided, that Seller is promptly notified of any such suit and Buyer offers Seller full and exclusive control of the defense of such suit or proceeding when products of Seller only are involved therein or the right to participate in the defense of such suit or proceeding when products other than those of Seller are also involved therein; except that this indemnity shall not extend to infringement resulting solely from Seller's compliance with Buyer's detailed design drawings, processes or formulas. In the event of an injunction or restraining order, Seller will, at its own expense, either procure for Buyer the right to continue to sell and use the item, or replace or modify the item so that it becomes non-infringing. Seller will also indemnify Buyer's customers and agents for such infringement if and to the extent that Buyer has agreed so to indemnify them, but to no greater extent than Seller has indemnified Buyer herein and under the same conditions as set forth herein.

8.C. INDEMNIFICATION AND INSURANCE

8.C.1 Seller indemnifies and holds harmless Buyer, its directors, officers, employees, agents and invitees from and against all liability, demands, claims, losses, costs, damages and expenses, including but not limited to attorneys' fees, by reason or on account of property damage, death or personal injury of whatsoever nature or kind arising out of, as a result of, or in connection with the performance of this order that is occasioned by the actions or omissions of Seller or its subcontractors or suppliers of any tier. Seller will maintain and carry liability insurance which includes but is not limited to commercial general liability (including product liability and for services to be performed, completed operations

liability) in a sum no less than \$5 million, automobile liability in a sum no less than \$5 million, workmen's compensation in an amount no less than the applicable statutory minimum requirement and employer's liability in an amount of no less than \$1 million, with internationally recognized insurance carriers. Seller will, if requested by Buyer, furnish certificates of insurance from its carrier(s) on the foregoing coverages, which will identify Buyer as an additional insured and provide that such coverage will not be changed without thirty (30) days advance written notification to Buyer from the carrier(s). Dollar amounts may be converted to local currency equivalents.

9. COMPLIANCE

9.A. STANDARDS OF CONDUCT, INTEGRITY, AND COMPLIANCE

9.A.1 Buyer conducts its business in strict compliance with applicable laws, rules, and regulations with honesty and integrity and with a strong commitment to the highest standards of health, safety and business ethics. In addition, it is the policy of Buyer to enter into representation or Supplier agreements only with companies which have a demonstrated record of, and commitment to, the highest ethical standards. Seller agrees that Seller will, at all times, adhere to the standards set forth in Danaher's "Code of Business Conduct" (hereinafter "Code") and will fully comply and take all necessary steps to assist Buyer in complying with the Code as well as any other customary standards of business conduct prescribed by law or regulation. (A copy of the Code may be obtained at <http://www.danaher.com/suppliers/>). Seller will, at all times, fully comply with all rules, laws and regulations pertaining to entertainment or providing gratuities. Buyer expects Seller to "Speak Up!" if aware of any violation of law, regulation or of the Code in relation to Buyer's business. The Danaher Integrity & Compliance Program Helpline portal is available www.danaherintegrity.com to report violations online or by phone. While on the premises of Buyer, Seller and its employees will comply with all applicable safety and health laws, regulations and ordinances and with Buyer's safety and plant rules.

9.B. NOTICE OF LABOR DISPUTES

9.B.1 Whenever Seller has knowledge that any actual or potential labor dispute is delaying or threatens to delay the timely performance of this order, Seller will immediately give notice thereof, including all relevant information with respect thereto, to Buyer. Seller will include this paragraph in each lower-tier Subcontract under this order.

9.C. SELLER'S STATUS

9.C.1 It is understood and agreed that Seller and/or its employees engaged in the performance of this order by the Seller, are not employees of Buyer and are not entitled to Buyer employee benefits or privileges or any payment from Buyer (other than as expressly provided for in this order) and the Seller will pay the salaries and expenses, and applicable taxes, including Social Security and unemployment of said employees. Seller will also pay any expenses normally paid by an employer in connection with its employees assigned to Buyer. The Seller is and will be deemed to be an Independent Contractor at all times during its performance of the work specified in this order.

9.D. COMPLIANCE WITH LAWS, GOVERNMENT PROVISIONS

9.D.1 Seller will comply with all applicable national, state and local laws, Executive Orders, rules and regulations during performance of this order including but not limited to, U.S. export/import compliance laws, the Occupational Safety and Health Act of 1970 as amended ("OSHA"), and State plans approved under this Act, the Toxic Substances Control Act as amended ("TSCA"), the Fair Labor Standards Act of 1938 as amended ("FLSA"), the Clean Air Act as amended, and the Anti Kickback Act of 1986 as amended.

9.D.2 Seller warrants that all representations and certifications furnished by Seller as required by law

or regulation in connection with this order are accurate, current and complete as of the effective date of this order, and that to Seller's knowledge no person has been paid a kickback or illegal gratuity in connection with this order.

9.D.3 Seller agrees to indemnify and hold Buyer and its customers harmless for any loss, damage or expenses sustained because any certification or representation herein or required by law or regulation made by Seller was inaccurate, non-current or incomplete or due to Seller's non compliance with any applicable law or regulation.

9.D.4 Seller agrees to provide Buyer, within five (5) business days of Buyer's request, written certification stating the extent of Seller's compliance with the above, including applicable laws or regulations newly coming into effect during the performance of the order.

9.D.5 If this order is issued under a U.S. Government contract or subcontract the provisions set forth in Buyer's form entitled "Government Contract Requirements" are incorporated herein by reference as though fully set forth.

9.D.6 CONFLICT MINERALS. Seller acknowledges that Buyer is required to comply with Section 1502 of the United States Dodd-Frank Wall Street Reform and Consumer Protection Act ("the Dodd-Frank Act") and among other requirements must file disclosures and reports with the United States Securities and Exchange Commission related to the use of tin, tantalum, tungsten and gold ("Conflict Minerals"). At Buyer's reasonable request, Seller must execute and deliver to Buyer declarations in the form of the EICC-GESI Conflict Minerals Reporting Template as adopted by EICC-GESI from time to time, or in any other form that Buyer reasonably requests. Unless the declarations provided by Seller pursuant to the prior sentence document to Buyer's reasonable satisfaction that Supplier is "Conflict Free" (as defined in the Dodd-Frank Act) with respect to all items supplied to Buyer, Seller agrees that it will source, and track the chain of custody of, all Conflict Minerals contained in any items provided by Seller to Buyer in accordance with the OECD Due Diligence Guidance for Responsible Supply Chains of Minerals from Conflict-Affected and High-Risk Areas (or such other internationally recognized due diligence standard as Buyer and Seller may jointly agree upon).

9.D.7 **Unless exempt, Buyer and Seller will abide by the requirements of 41 CFR §§ 60-1.4(a), 60-300.5(a) and 60-741.5(a). These regulations prohibit discrimination against qualified individuals based on their status as protected veterans or individuals with disabilities, and prohibit discrimination against all individuals based on their race, color, religion, sex, or national origin. Moreover, these regulations require that covered prime contractors and subcontractors take affirmative action to employ and advance in employment individuals without regard to race, color, religion, sex, national origin, protected veteran status or disability.** If applicable, Seller and Buyer will also abide by the requirements 41 CFR § 61-300.10 regarding veterans' employment reports and 29 CFR Part 471, Appendix A to Subpart A regarding posting a notice of employee rights.

10. COUNTERFEIT PARTS OR MATERIALS

10.A. INDEMNIFICATION

10.A.1 Seller shall not deliver any Product to Buyer containing any "Counterfeit Parts" as defined in Buyer's Standard Operating Procedure – Counterfeit Parts (McCrometer OP-233, reprinted herein as Attachment B) as such procedure may be amended from time to time. Seller shall indemnify and hold harmless Buyer and its officers, directors and affiliated companies from any and all losses, damages, claims, costs and expenses for Seller's failure to comply with McCrometer OP-233.

10.A.2 Seller shall indemnify Buyer, its agents, and assignees for any financial loss, injury, or property damage resulting directly or indirectly from material, components, or parts furnished or used under this

Purchase Order that are not genuine, original, and unused, or otherwise not suitable for the intended purpose. Seller's indemnity includes any financial loss, injury, or property damage resulting directly or indirectly from items furnished or used under this Purchase Order that are defective, suspect, or counterfeit; or that have been provided under false pretenses; or that are materially altered, damaged, deteriorated, degraded, or result in product failure.

10.A.3 Suspect/counterfeit items furnished under any Purchase Order will be impounded by Buyer. Seller must promptly replace them with items acceptable to Buyer, and Seller shall be liable for all costs relating to discovery, removal, impoundment, and replacement of materials and equipment that contain or exhibit suspect or counterfeit item characteristics or conditions.

10.A.4 The rights of Buyer in this clause are in addition to any other rights provided by law or contract.

10.A.5 Seller shall include this clause in Subsupplier agreements hereunder.

11. OTHER TERMS

11.A. RELEASE OF INFORMATION TO PUBLIC

11.A.1 Seller will not, without the prior written consent of Buyer, make any release of information concerning this order or any other information related to the Buyer (other than to Seller's employees and subcontractors that is required for the performance of their duties), including providing copies of this order or identifying the Goods sold by Seller to Buyer, nor use the name of Buyer in any advertising or publicity, except as may be necessary to comply with a subpoena or other proper mandatory legal demand.

11.B. ORDER OF PRECEDENCE

11.B.1 In the event of any conflict among the provisions of this order, the following order of precedence applies in interpreting this order: (i) the text of Buyer's order, then (ii) any special or supplemental terms and conditions that Buyer incorporates by reference into the order, then (iii) these McCrometer, Inc's Terms and Conditions of Purchase, and finally (iv) other contract documents.

11.C. APPLICABLE LAW AND DISPUTE RESOLUTION

11.C.1 The construction, interpretation and performance hereof and all transactions hereunder shall be governed by the laws of the State of California, U.S.A. without regard to or application of its principles or laws regarding conflicts of laws, and excluding the United Nations Convention on the International Sale of Goods of 1980 (and any amendments or successors thereto). Any dispute not resolved by the parties shall be adjudicated in order of preference (i) by a court of competent jurisdiction in the State of California, U.S.A. if Seller has minimum contacts with California and the United States, (ii) by a court of competent jurisdiction elsewhere in the United States if Seller has minimum contacts with the United States but not California, or (iii) by a court of competent jurisdiction in a neutral location if Buyer does not have minimum contacts with the United States.

11.D. RIGHTS AND REMEDIES OF BUYER

11.D.1 The rights and remedies of Buyer set forth herein are in addition to any other rights and remedies provided in law or equity, including all implied warranties and all of Buyer's remedies set forth in the Uniform Commercial Code.

11.E. NON-WAIVER

11.E.1 No failure by Buyer to assert its rights under any provision of this order, or failure of Seller to perform any provision of this order, is effective as a waiver thereof unless consented to in writing by

the Buyer; nor does any such waiver constitute an advance waiver of any other provision or failure to perform.

11.F. ASSIGNMENT AND SUBCONTRACTING

11.F.1 Any assignment or subcontract by Seller for all or a majority of the materials and/or labor to be supplied by Seller under this order are void unless consented to by Buyer in writing. Buyer may assign this order to one of Buyer's subsidiaries or affiliates or in connection with the sale or transfer of all or substantially all of the assets of the business to which it pertains.

11.G. HEADINGS

11.G.1 Headings and captions set forth in this order are for convenience of reference only and are not intended to, nor do they, alter the meaning, content or enforceability of any Article hereof.

11.H. SEVERABILITY

11.H.1 In the event any provision of this order is determined to be illegal, invalid, or unenforceable, the validity and enforceability of the remaining provisions of this order will not be affected and, in lieu of such illegal, invalid, or unenforceable provision, there will be added as part of this order one or more provisions as similar in terms as may be legal, valid and enforceable under applicable law.

11.I. SURVIVAL

11.I.1 Articles 1, 2, 5, 6, 7 and 8 will survive expiration or any cancellation or termination of this Order.

Remainder of page left intentionally blank.

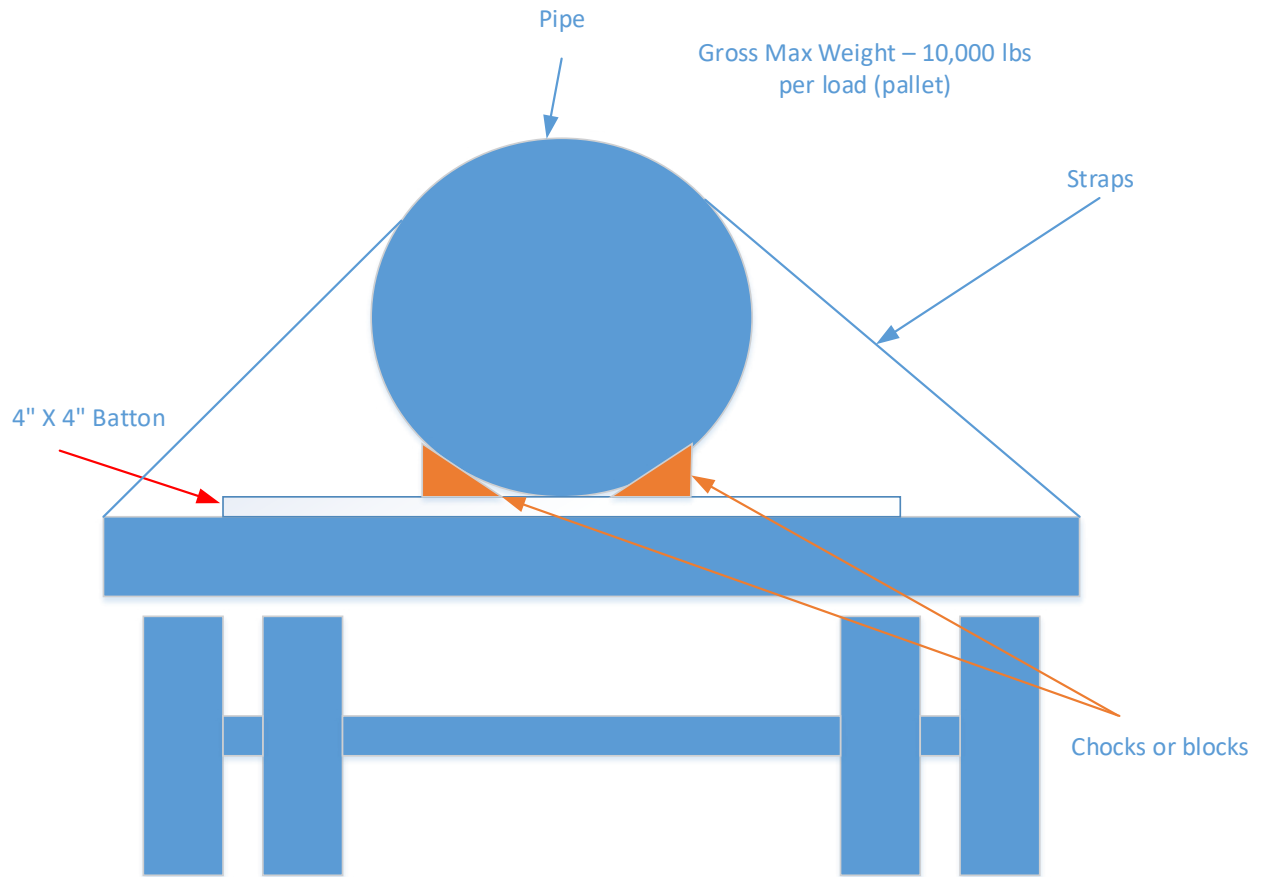

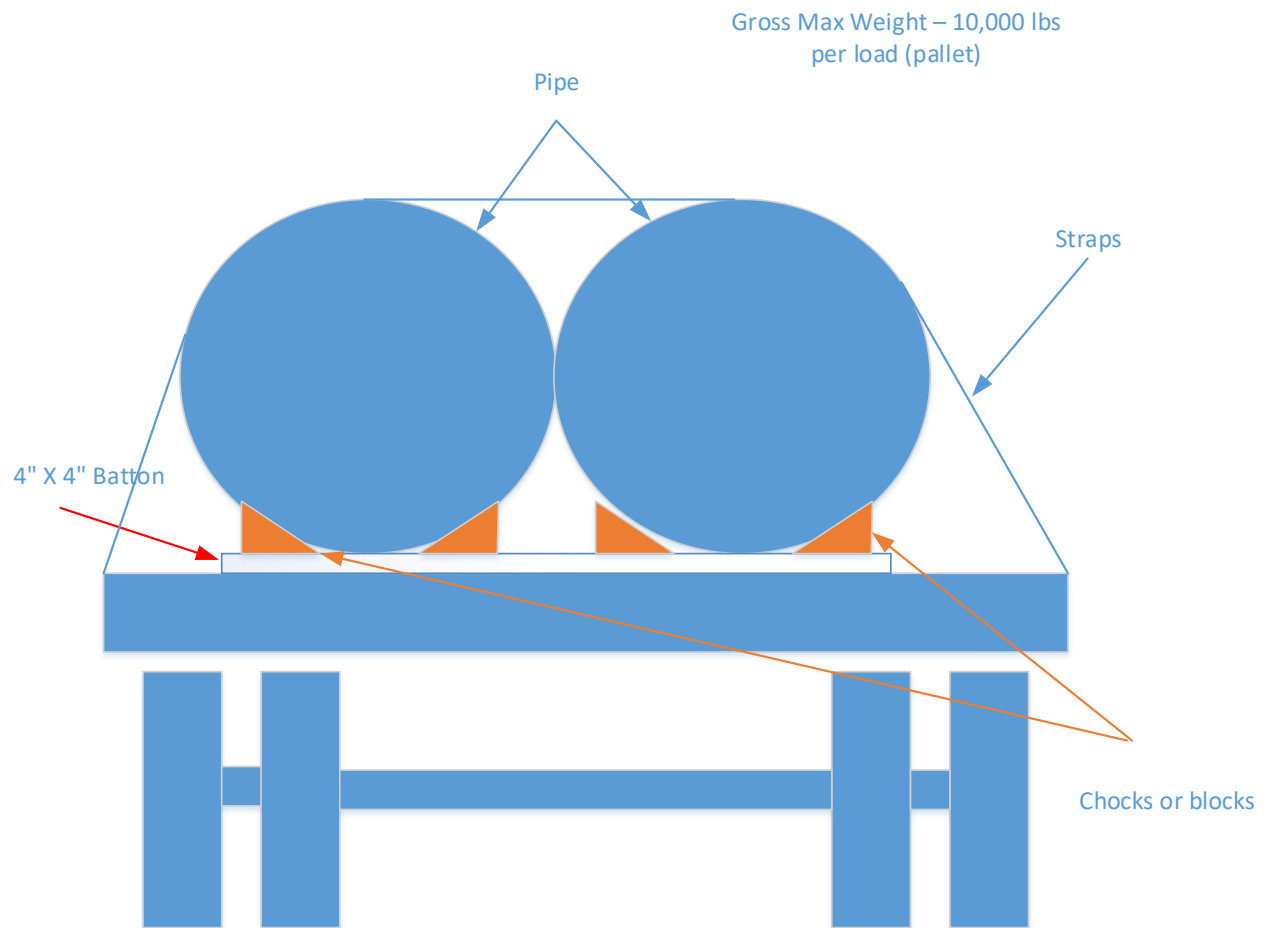

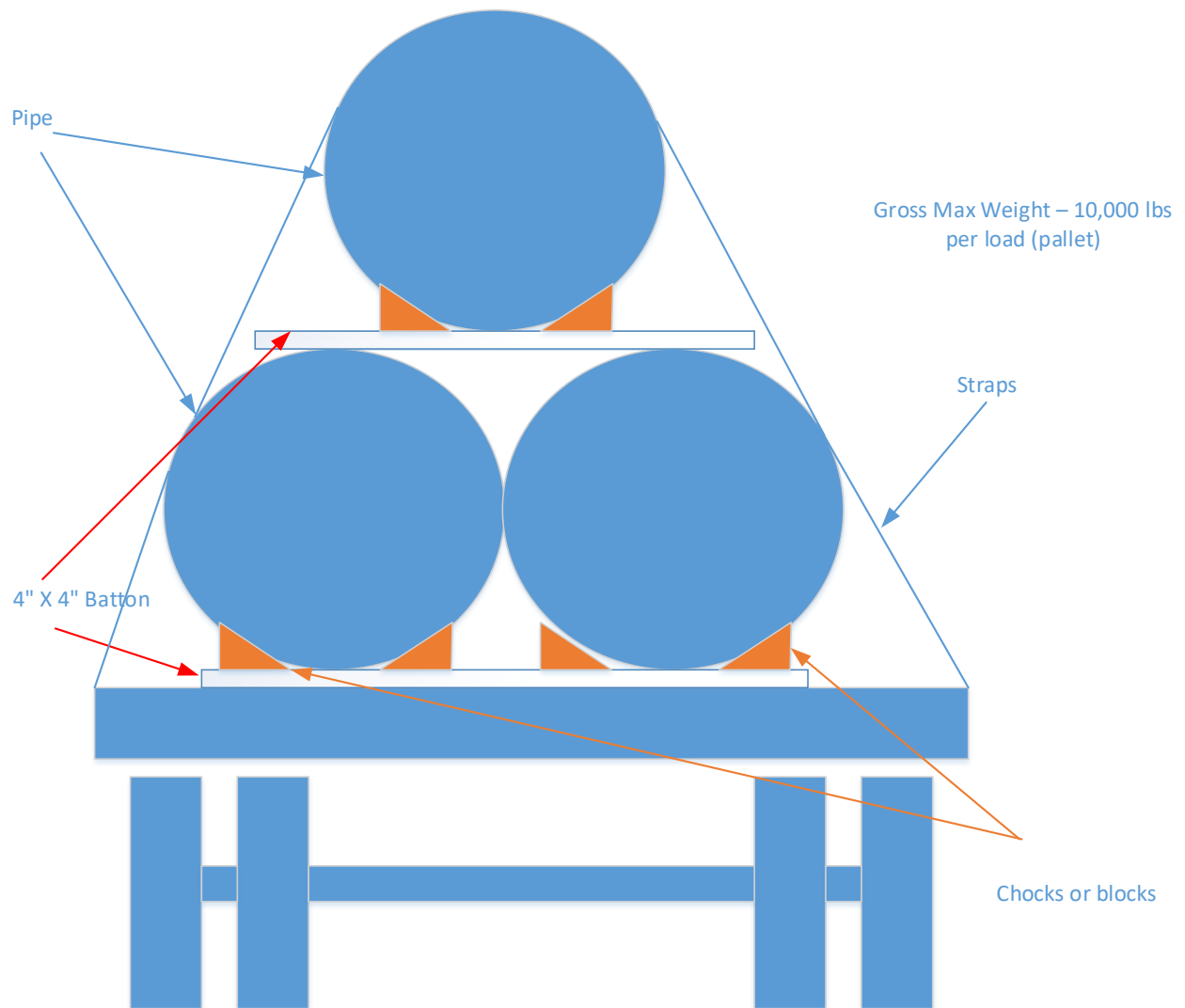

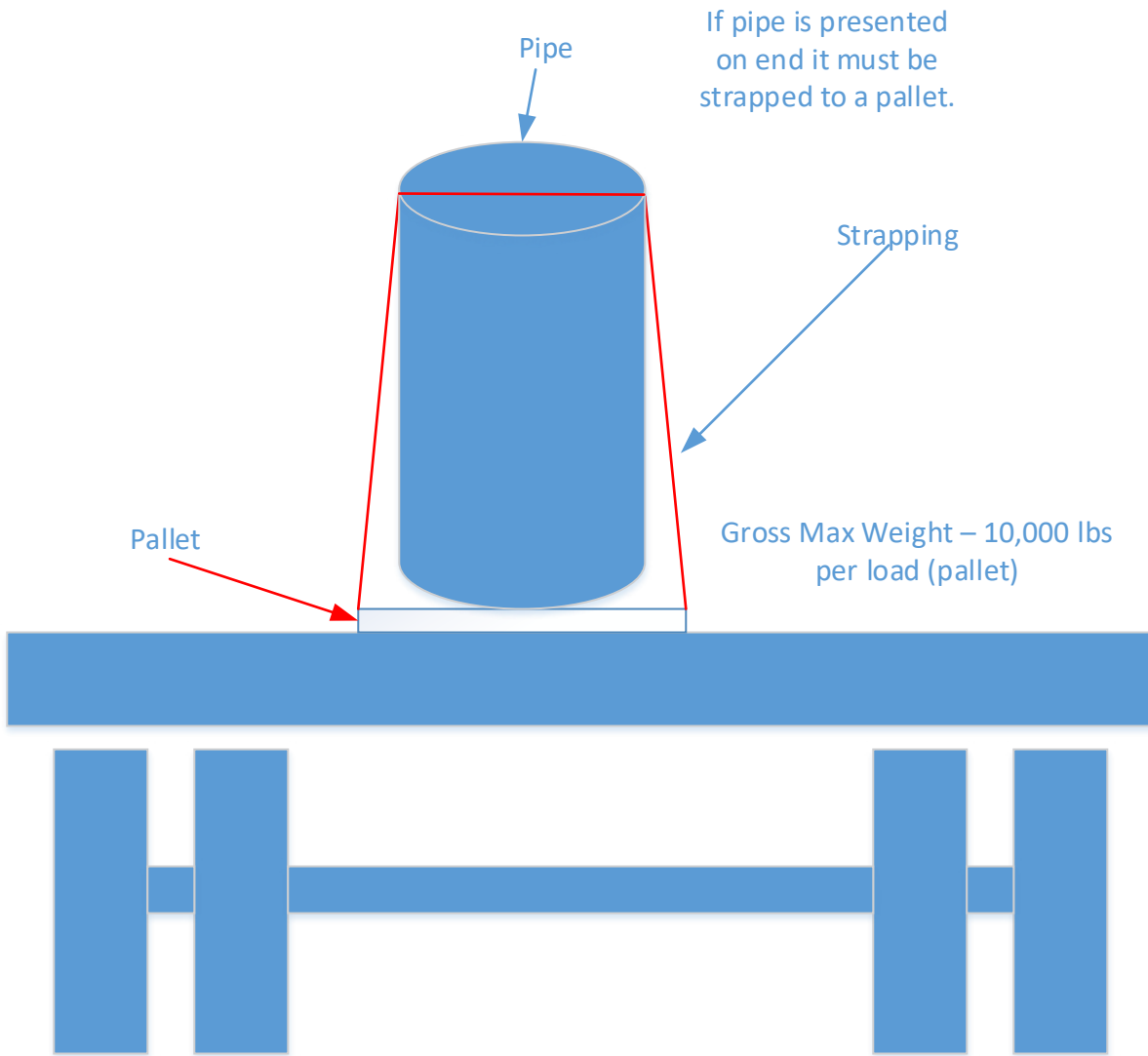

QUALITY OPERATING PROCEDURE**Procedure for Suspect/Counterfeit Items**

MCC-OP-233	Rev: 1.0	Date: 7/23/2018
Approval:		Memphis Huff

Revision Record: Maintained in Controlled Document Library.

1.0 Purpose

- 1.1 This document defines the process and due diligence performed by McCrometer to identify and prevent the procurement, installation, use, and/or delivery of Suspect and Counterfeit Parts.

2.0 Scope

- 2.1 This document applies to the procurement and inspection activities at McCrometer to the extent specified within.

3.0 Responsibility

Purchasing, engineering, receiving / material distribution, quality, and other designated associates are responsible to comply with the requirements and processes identified in this document.

- 3.1 Purchasing is responsible for procuring the correct part(s) using the applicable drawing, specification, description, or other information to meet the intended use. Purchasing is responsible to reference and / or attach the following statement to each purchase order. "Seller shall not deliver any Product to Buyer containing any "Counterfeit Parts" as defined in Buyer's Standard Operating Procedure – Counterfeit Parts (McCrometer OP-233) as such procedure may be amended from time to time. Seller shall indemnify and hold harmless Buyer and its officers, directors and affiliated companies from any and all losses, damages, claims, costs and expenses for Seller's failure to comply with McCrometer OP-233."
- 3.2 Engineering is responsible for ensuring the drawing, specification, process, or other description identifies the applicable type, class, style, part number, manufacturer, or other related information so the correct part or product is identified.
- 3.3 Receiving / Materials Associates may be responsible to examine, inspect, select, kit, and / or maintain the parts to identify or mitigate the receipt and / or use of counterfeit parts.
- 3.4 Quality is responsible to control parts identified as counterfeit and report the counterfeit parts to other potential users and Government investigative authorities.

Procedure for Suspect/Counterfeit Items**MCC-OP-233****Rev: 1.0****Date: 7/23/2018****Approval: Memphis Huff**

- 3.5 Materials Supervisor is responsible to train, direct and maintain training of Receiving / Materials Associates to examine, inspect, select, kit, and / or maintain the parts to identify or mitigate the receipt and / or use of counterfeit parts.

4.0 Definitions

- 4.1 Suspect Part - A part in which there is an indication by visual inspection, testing or other information that it may not conform to established Government – or industry – accepted specifications or national consensus standards.
- 4.2 Counterfeit Part – A suspect part identified as a copy or substitute without legal right or authority to do so or one whose materials, performance, or characteristics are knowingly misrepresented by the vendor, supplier, distributor, or manufacturer. The Counterfeit Parts include but are not limited to:
- 4.2.1 Parts not containing the proper internal construction consistent with the desired produced or ordered part.
- 4.2.2 Used, refurbished, or reclaimed parts represented as new product.
- 4.2.3 Parts with different package style, type, or surface plating / finish than the product ordered.
- 4.2.4 Parts not successfully completing the full production and / or required testing of the Original Equipment Manufacturer (OEM) or Original Component Manufacturer (OCM) that are represented by a completed product.
- 4.2.5 Parts that fail to meet the specifications of Material Test Reports (MTR).
- 4.2.6 Parts sold or delivered as upscreens product that have not successfully completed the upscreens process.
- 4.2.7 Parts sold or delivered with modified labeling or markings intended to misrepresent the form, fit, function, or grade of the intended product.

Procedure for Suspect/Counterfeit Items**MCC-OP-233****Rev: 1.0****Date: 7/23/2018****Approval: Memphis Huff**

Note: Parts sold as refinished, upscreened, or uprated and have been identified as such are not considered counterfeit product.

- 4.3 Approved Supplier – Suppliers who are formally assessed and determined to have a low risk of providing counterfeit product. These suppliers are incorporated and listed as an approved suppliers on McCrometer's Approved Supplier List (ASL) (McCrometer OP-211 Supplier Controls)
- 4.4 Authorized Supplier – Aftermarket manufacturers (reference Section 4.3) and OCM authorized sources of supply for a specific part.
- 4.5 Certificate of Conformance (C of C) – A separate document provided by the supplier formally declaring the purchase order requirements are met. This separate document may include information relative to the manufacturer, distributor, quantity, and the date code. This separate document must be signed and dated by an associate authorized to represent the Supplier.
- 4.6 Certificate of Conformance and Traceability (C of CT) – A certificate of conformance applicable to some military specifications requiring documented traceability of the product from the Qualified Parts List / Qualified Materials manufacturer through the product delivery to the Government.
- 4.7 Packaging – Component packaging refers to the manner the electronic parts are packaged in preparation for use. There are four basic types of packaging: (A) Bulk, (B) Tray, (C) Tube, and (D) Reel.
- 4.8 Refinished – Using a plating process method after manufacture to alter the original plating composition on a part lead or a lead wire.
- 4.9 Refurbished – Subjecting parts to a process to brighten, polish, or renovate the item in an effort to restore the item to a “like new” condition. Refurbished parts may have the leads realigned and tinned.
- 4.10 Uprated – Assessment resulting in an extension of a parts rating to meet performance requirements for an application where the part is used outside the specification range of the manufacturer.
- 4.11 Upscreened – Additional part testing performed to produce parts verified beyond the specification parameters of the manufacturer.

Procedure for Suspect/Counterfeit Items**MCC-OP-233****Rev: 1.0****Date: 7/23/2018****Approval: Memphis Huff****5.0 Process**

- 5.1 Purchasing, planning, and design associates assess the availability of original or authentic product in support of manufacturing operations.
- 5.2 Purchasing must examine every potential source of supply to assess the risk of receiving counterfeit parts. Assessment may be a survey, audit, product alert review, and a review of the supplier quality data to determine performance.
- 5.3 Purchasing should obtain parts directly from an OEM or OCM, approved distributor, authorized resell organization, or franchised aftermarket supplier.
- 5.4 Purchasing should obtain parts from an independent distributor or part broker **ONLY** as a last resort. Purchasing must contact Quality for guidance to determine if McCrometer must obtain documented permission from the Customer on the use of an independent distributor or part broker before processing the purchase order.
- 5.5 Purchasing must maintain a list of approved suppliers to minimize the risk associated with the supply and / or receipt of counterfeit parts. Suppliers referenced in the McCrometer's Approved Supplier List are considered approved (McCrometer OP-211).
- 5.6 Purchasing must specify the flowdown requirements from the Counterfeit Parts Procedure applicable to the supplier or subcontractor. Purchasing must perform some level of risk assessment if the supplier or subcontractor does not maintain a documented counterfeit part control plan.
- 5.8 The purchase order must specify the applicable requirements of the Counterfeit Part Procedure to the supplier to minimize the risk of receiving counterfeit parts. The language should include requirements to ensure conforming, original, and authentic parts are provided. The purchasing document may list certification or traceability requirements, test and / or inspection results, Quality System requirements for the supplier, a statement of financial responsibility, the length of obligation, and any penalties associated with fraud.
- 5.9 Per the specified inspection or test instructions by McCrometer, associates receiving or processing the parts must examine the product to ensure the drawing, specification, type, class, style, marking, part number, manufacturer, date code, or other related information is present and correct to detect or identify suspect or counterfeit parts.

When the evidence indicates the material may be suspect or counterfeit parts the lot of product is placed in a bonded location and Quality is notified of the nonconformance. The purpose is to identify, separate, and segregate the nonconforming parts to the proper location.

Procedure for Suspect/Counterfeit Items**MCC-OP-233****Rev: 1.0****Date: 7/23/2018****Approval: Memphis Huff**

- 5.10 When further investigation removes all doubt the parts are suspect or counterfeit, the nonconforming material document may be dispositioned "Accept" and moved into stock.
- 5.11 Purchasing, quality, and operations may aid supplier quality in the disposition of suspect or counterfeit parts. McCrometer may contact legal counsel for guidance.
- 5.12 A suspect and verified counterfeit part must be reported to Management and must remain at McCrometer. Management should contact legal counsel.
- 5.13 Management is responsible to determine how the counterfeit part occurrence is reported internally, to Customers, to the Government, the Government Cooperative (GIDEP), other industry reporting programs, and criminal authorities.

6.0 Reference Documentation

- 6.1 10 CFR 830.120
- 6.2 DOE O 414.1C, Quality Assurance
- 6.3 DOE G 414.1-3 Suspect/Counterfeit Items Guide for Use with 10 CFR 830 Subpart A. Quality Assurance Requirements
- 6.4 McCrometer OP-211 Supplier Controls