

CASE STUDY

Pacific Klamath Energy Utilizes V-Cone[®] Flow Meter To Solve Problem In Co-Generation Plant

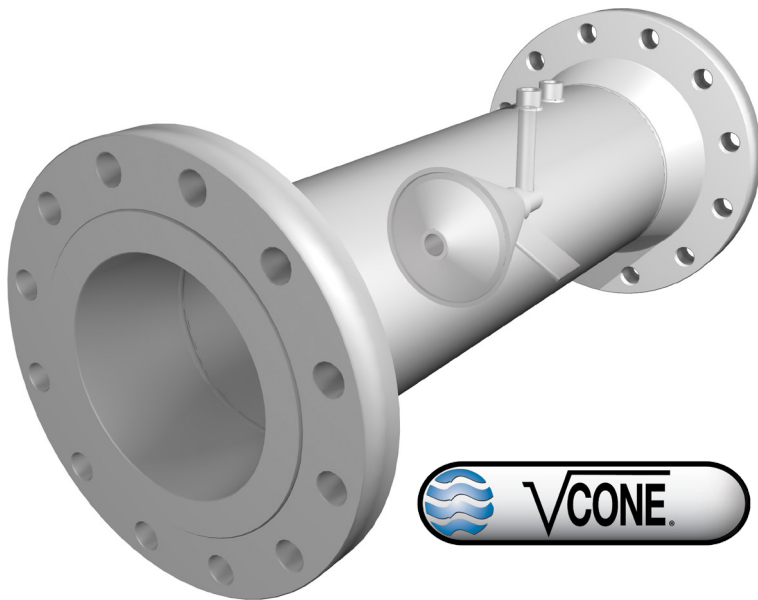

Pacific Klamath Energy Utilizes V-Cone Flow Meter To Solve Problem In Co-Generation Plant

By Nick Voss V-Cone Product Manager, McCrometer, Inc.
& Bruce Willard Pacific Klamath Energy Plant Engineer

Pacific Klamath Energy operates a 500 MW electric co-generating station for the City of Klamath Falls in Klamath Falls, Oregon. The plant also provides steam service to a local wood products manufacturing facility (steam host). The co-generation station provides electricity for about 450,000 residents, and the wood products manufacturing plant employs about 100 people.

The co-generation station is located on 25 acres in Klamath Falls next to its steam host. The plant's co-generation source is augmented by 3 different steam systems and has provided greater than 95% reliability.

Pacific Klamath Energy is a subsidiary of PPM Energy that is based in Portland, Oregon. PPM Energy is also involved in natural gas resources, wind, and solar energy projects throughout the U.S.

The Problem

Providing accurate and reliable steam flow measurement to the steam host is a very important aspect in generating revenue for the co-generation facility. The existing annubar flow measurement system could not measure the low end of the steam flow requirements without major changes to the piping and purchasing a new annubar.

Steam design flows were up to 150,000 pph maximum, with the average steam flow of

70,000 pph annually. Steam conditions are controlled to 320 psig with 10 degrees of superheat or greater at the customer's delivery point which is about 1 mile away.

The Solution

To eliminate this problem, Klamath Pacific Energy contacted McCrometer and asked them about the V-Cone Flow Meter, which relies on differential pressure (DP) technology. We then decided to replace the annubar system based on the expected accuracy of the V-Cone Flow Meter and its space-saving installation requirements that allowed us to make only minimal changes to our piping layout.

Accurate to +0.5%, with a repeatability of +0.1%, over a 10:1 flow range, the V-Cone typically requires only 0-3 pipe straight diameters upstream and 0-1 diameters downstream from the meter for accurate flow measurement. Nearly all other types of flow meters require as many as 10 pipe straight diameters upstream and 5 pipe diameters downstream from the meter to prevent swirl and other pipeline disturbances from affecting measurement accuracy.

The V-Cone typically reduces plant real estate needs, piping material, associated pipe support structure and installation labor by 50 percent or more. The bigger the line size, the bigger the savings with the V-Cone. For example

when the V-Cone is installed in a typical 36-inch steam process line, it requires from 0 to 3 straight pipe diameters (0-108 inches) upstream and 0-1 (0-36 inches) downstream. A conventional flow meter would require a straight run of 360 inches upstream and 180 inches downstream. Add an elbow or U-joint if the pipeline needs to double back and the straight pipe diameter requirements will then double in cost.

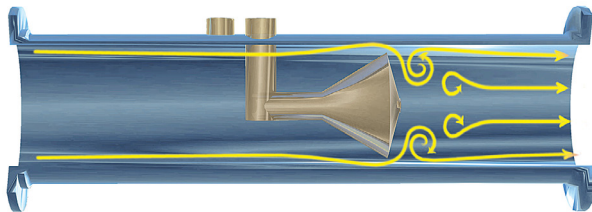

The V-Cone Built-In Flow Conditioning

Unlike traditional DP instruments, such as orifice plates and Venturi tubes, the V-Cone Flow Meter's design is inherently more accurate because the flow conditioning function is built-into the basic instrument. The V-Cone conditions fluid flow to provide a stable flow profile that increases accuracy. It features a centrally-located cone inside a tube. The cone interacts with the fluid flow and reshapes the velocity profile to create a lower pressure region immediately downstream.

The pressure difference, which is exhibited between the static line pressure and the low pressure created downstream of the cone, can be measured via two pressure sensing taps. One tap is placed slightly upstream of the cone and the other is located in the downstream face of the cone itself. The pressure difference can then be incorporated into a derivation of the Bernoulli equation to determine the fluid flow rate.

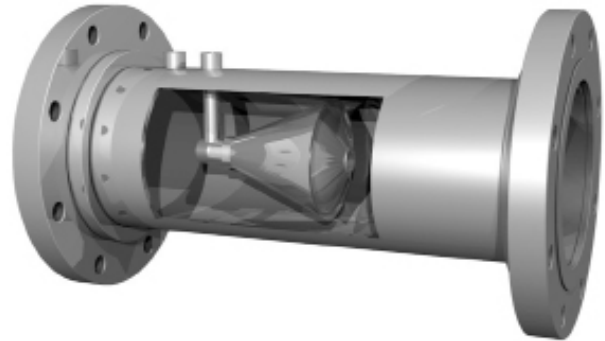

The V-Cone Flow Meter's Centrally Located Cone

The cone's central position in the line optimizes the velocity of the liquid flow at the point of measurement. It forms very short vortices as the flow passes the cone. These short vortices create a low amplitude, high frequency signal for excellent signal stability. The result is a highly stable flow profile that is repeatable for continuously accurate flow measurement.

Conclusion

McCrometer matched both ends of the flow meter to the existing steam system piping dimensions and provided multiple taps for flow readings. With the aid of their sales and engineering departments we were guaranteed a flow accuracy of + 0.5 percent that included equations to assist in the setup and calibration of their flow meter at our site. The installation was easy and the calibration by a third party was accomplished on-time and under budget.

[**Click Here To Learn More
About McCrometer's V-Cone Flow Meter**](#)