

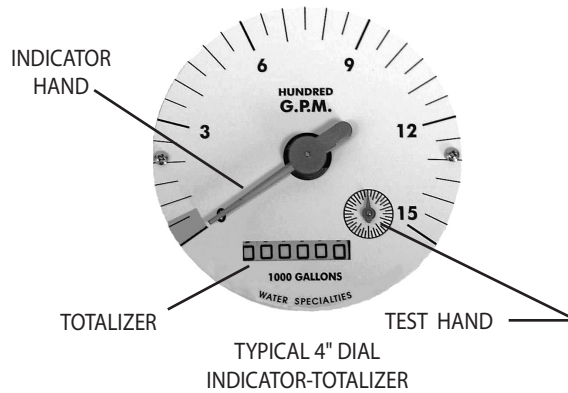

MODEL ML12
 150 psi PLAIN END TUBE METER
 SEALED METER MECHANISM - MAGNETIC DRIVE
 INDICATOR - TOTALIZER
 SIZES 3" thru 48"



DESCRIPTION

MODEL ML12 PLAIN END TUBE METERS are manufactured to the highest standards. Materials used on all meters and flow ranges meet or exceed AWWA standard C704-02. The plain end tube design permits use in a wide range of applications with up to 150 psi working pressure. Fabricated steel meter tubes have straightening vanes and are protected internally and externally with 12-15 mils of fusion epoxy resin.

INSTALLATION is made similar to placing a short length of plain end pipe in the line by using one of the many types of pipe couplings available. The meter can be installed in any of the following positions: horizontally or inclined on suction or discharge lines. The meter must have a full flow of liquid for proper accuracy. Fully opened gate valves, fittings or other obstructions that tend to set up flow disturbances should be a minimum of five pipe diameters upstream and one pipe diameter downstream from the meter.

PROPELLER is magnetically coupled with the drive mechanism through the sealed oil filled gearbox. This completely eliminates water entering the meter assembly, as well as the need for any packing gland. The propeller is a conical shaped three bladed propeller, injection molded of thermoplastic material resistant to normal water corrosion and deformity due to high flow velocities.

BEARING in propeller is a water lubricated ceramic sleeve and spindle bearing system with a ceramic/stainless steel spindle. Dual ceramic thrust bearings, standard on all meters, handle flows in both forward and reverse directions. The bearing design promotes extended periods of maintenance free propeller operation. Bearings within the sealed meter mechanism are shielded precision stainless steel bearings and are factory lubricated for the life of the meter.

INDICATOR-TOTALIZER is mechanically driven by the meter mechanism and features a full 4" diameter, 250 degree sweep dial with a six digit, straight reading type totalizer and sweep test hand. The indicator drive mechanism is temperature compensated so the indicator will be accurate at all points on the dial when operated between 32° and 140° F. The indicator dial can be furnished in GPM, CFS, MGD or any standard liquid measuring units with choice of standard totalizer measuring units. The bonnet, with padlock hasp, is o-ring sealed to the meter head.

CHANGE GEARS may be easily exchanged in the field when changing the dial, or when recalibrating for different pipe sizes. It is not necessary to remove pressure from the line for these changes.

O-RING SEALS are used at the meter head and all points where seals are required, making the meter mechanism completely immune to any of the corrosive effects of atmospheric moisture or the liquids measured by the meter assembly.

SPECIFICATIONS

ACCURACY	Plus or minus 2% of actual flow within the range specified for each meter size.
PRESSURE RANGE	Up to 150 PSI maximum working pressure.
TEMPERATURE RANGE	140° F Maximum. Consult factory for special construction for higher temperatures.
MINIMUM FLOWS	As shown for each meter size and construction are required for accurate registration. See flow chart. NOTE: Minimum flow will be higher when auxiliary equipment is added.
MAXIMUM FLOWS	As shown for each meter size and construction are required for accurate registration. See flow chart.
INTERMITTENT FLOWS	As shown for each meter size are rated for 10% to 15% of the total time the meter is operating. Consult factory for High Velocity construction when intermittent flows are higher than shown on flow chart and/or when longer operating periods are required.
MATERIALS	Used in construction are chosen to minimize the corrosive effects of the liquids measured by the meter assembly. MAGNETS - anticorrosive aluminized barrier coated magnets; Everlube 6155. INTERIOR BEARINGS - shielded stainless steel. PROPELLER BEARING - ceramic sleeve type. PROPELLER SPINDLE - ceramic coated stainless steel. PROPELLER - injection molded thermoplastic. GEARBOX - stainless steel. SEPARATOR - stainless steel. SHAFTS - stainless steel. METER HEAD BOLTS - stainless steel (3"-20"), plated steel (24"-48"). METER HEAD - cast iron or fabricated steel, fusion epoxy coated. METER TUBE - fabricated steel with straightening vanes, coated inside and out with 12-15 mils of fusion epoxy by the fluidized bed method.
OPTIONAL EQUIPMENT	A meter mounted Fwd. & Rev. Totalizer, Totalizer Extensions and a wide range of controls and instruments for indicating, totalizing and recording flow data for each meter. Special constructions and materials are available upon request.
ORDERING INFO	Must be specified by the customer and includes: Minimum & maximum flow ranges, temperature of meter environment, totalizer dial units, type of materials and construction, and optional equipment desired.

MODEL ML12
 150 psi PLAIN END TUBE METER
 SEALED METER MECHANISM - MAGNETIC DRIVE
 INDICATOR - TOTALIZER
 SIZES 3" thru 48"

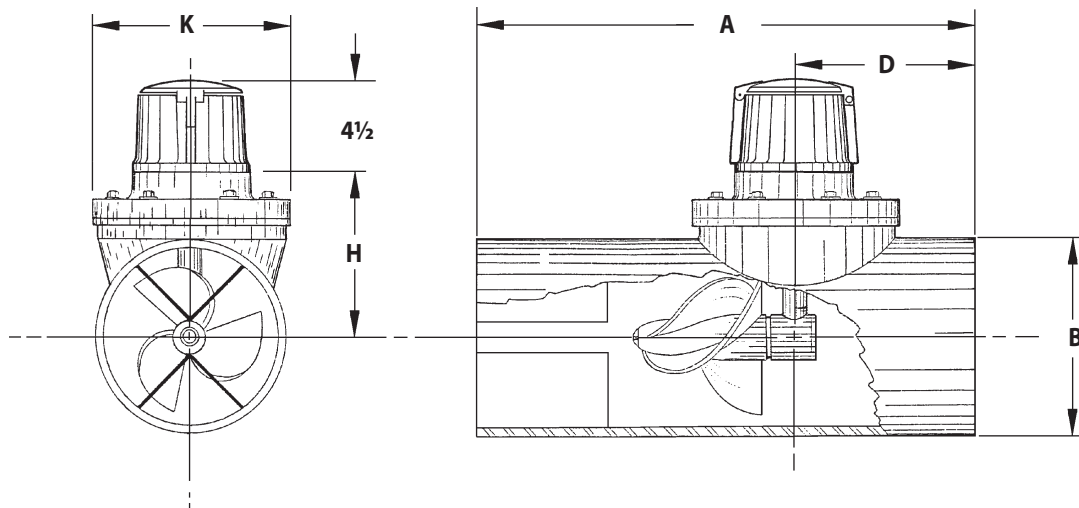

METER & PIPE SIZE	FLOW RANGES, GPM STANDARD CONSTRUCTION MIN-MAX-INT	HIGH VELOCITY CONSTRUCTION MIN-MAX	DIMENSIONS					EST. SHIPPING WEIGHT POUNDS
			A	B	D	H	K	
3	45-250-350	N/A	17	3½	6½	5 ³ / ₁₆	9	45
4	55-500-700	200-700	17	4½	6½	5 ³ / ₁₆	9	60
6	120-1200-1500	300-1500	21	6 ⁵ / ₈	8½	6¼	9	95
8	150-1500-2000	400-2500	23	8 ⁵ / ₈	8½	7¼	9	115
10	180-2000-3000	500-3500	25	10¾	9½	8¼	11	170
12	200-3000-3500	800-5000	27	12¾	9½	9½	11	195
14	300-4000-4500	1000-6000	41	14	11½	10½	13½	295
16	400-5000-6000	1200-7500	47	16	11½	11½	13½	435
18	700-6000-7500	1500-9000	53	18	14½	12½	13½	520
20	850-8000-9000	2000-12000	59	20	14½	13½	13½	610
24	1000-10000-13500	3000-15000	71	24	17½	17½	21	1010
30	1800-15000-21000	4000-25000	83	30	17½	20½	21	1660
36	2000-20000-30000	5000-35000	95	36	19½	23½	21	2290
42	3000-30000-40000	6000-50000	95	42	23½	27	32	3500
48	5500-35000-50000	7000-60000	95	48	23½	30	32	3780

Standard construction will be supplied for all mainline meters unless special flow range, materials or construction are required.