

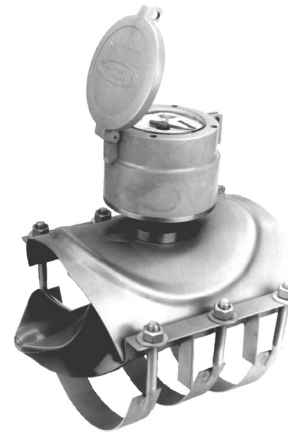

**MODEL LP32**  
 150 PSI STRAP-ON SADDLE METER  
 SEALED METER MECHANISM - MAGNETIC DRIVE  
 STAINLESS STEEL STRAP-ON SADDLE  
 INDICATOR-TOTALIZER  
 SIZES 6" thru 20"

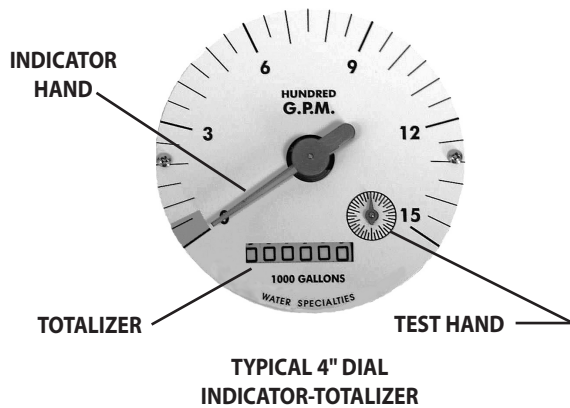

TYPICAL 4" DIAL  
 INDICATOR-TOTALIZER

#### DESCRIPTION

**MODEL LP32 STRAP-ON SADDLE METERS** are designed for irrigation or other low pressure service up to 150 PSI working pressure. The stainless steel saddle and u-straps permit installation on a wide range of steel, cast-iron, plastic (3/16" PVC wall minimum), asbestos, and other pipe materials for each nominal meter size. It is necessary upon ordering to furnish the I.D. dimension of the pipe the meter is to be mounted on, for calibration purposes. The pipe O.D. dimension (20" max.) or wall thickness must also be furnished for proper sizing of the U-straps. NOTE: Consult factory for O.D. larger than 20".

**INSTALLATION** is made by cutting a hole in the existing pipe line and then attaching the meter securely to the line. U-straps for attaching the meter saddle to the line are furnished with each meter. The meter can be installed horizontally, or inclined on suction or discharge lines. The meter must have a full flow of liquid for proper accuracy. Fully opened gate valves, fittings or other obstructions that tend to set up flow disturbances should be a minimum of ten pipe diameters upstream and two pipe diameters downstream from the meter. Installations with less than ten pipe diameters of straight pipe require straightening vanes. Meters with straightening vanes require at least five pipe diameters upstream and two pipe diameters downstream.

**PROPELLER** is magnetically coupled with the drive mechanism through the sealed oil filled gearbox. This completely eliminates water entering the meter assembly, as well as the need for any packing gland. The propeller is a conical shaped three bladed propeller, injection molded of thermoplastic material resistant to normal water corrosion and deformity due to high flow velocities.

**BEARING** in propeller is a water lubricated ceramic sleeve and spindle bearing system with a ceramic/stainless steel spindle. Dual ceramic thrust bearings, standard on all meters, handle flows in both forward and reverse directions. The bearing design promotes extended periods of maintenance free propeller operation.

**INDICATOR-TOTALIZER** is mechanically driven by the meter mechanism and features a full 4" diameter, 250 degree sweep dial with a six digit, straight reading type totalizer and sweep test hand. The indicator drive mechanism is temperature compensated so the indicator will be accurate at all points on the dial when operated between 32° and 140° F. The indicator dial can be furnished in GPM, CFS, MGD or any standard liquid measuring units with choice of standard totalizer measuring units. The bonnet, with padlock hasp, is O-ring sealed to the meter head.

**CHANGE GEARS** may be easily exchanged in the field when changing the dial, or when recalibrating for different pipe sizes. It is not necessary to remove pressure from the line for these changes.

**O-RING SEALS** are used at the meter head and all points where seals are required, making the meter mechanism completely immune to any of the corrosive effects of atmospheric moisture or the liquids measured by the meter assembly.

#### SPECIFICATIONS

<b>ACCURACY</b>	Plus or minus 2% of actual flow within the range specified for each meter size.
<b>PRESSURE RANGE</b>	Up to 150 PSI maximum working pressure.
<b>TEMPERATURE RANGE</b>	140° F Maximum. Consult factory for special construction for higher temperatures.
<b>MINIMUM FLOWS</b>	As shown for each meter size and construction are required for accurate registration. See flow chart. NOTE: Minimum flow will be higher when auxiliary equipment is added.
<b>MAXIMUM FLOWS</b>	As shown for each meter size and construction are rated for continuous operation. See flow chart.
<b>INTERMITTENT FLOWS</b>	As shown for each meter size are rated for 10% to 15% of the total time the meter is operating. Consult factory for High Velocity construction when intermittent flows are higher than shown on flow chart and/or when longer operating periods are required.
<b>MATERIALS</b>	Used in construction are chosen to minimize the corrosive effects of the liquids measured by the meter assembly. <b>MAGNETS</b> – anticorrosive aluminized barrier coated magnets; Everlube 6155 <b>VERTICAL SHAFT BEARING</b> - shielded stainless steel <b>PROPELLER BEARING</b> - ceramic sleeve type <b>PROPELLER SPINDLE</b> - ceramic sleeve/stainless steel <b>PROPELLER</b> - injection molded thermoplastic <b>GEARBOX</b> - stainless steel <b>SEPARATOR</b> - stainless steel <b>SHAFTS AND BOLTS</b> - stainless steel <b>SADDLE</b> - stainless steel <b>LUG STRIPS</b> - stainless steel <b>U-STRAPS</b> - stainless steel
<b>OPTIONAL EQUIPMENT</b>	Totalizer extensions and a wide range of controls and instruments for indicating, totalizing and recording flow data for each meter. Special constructions and materials are available upon request.
<b>ORDERING INFO</b>	Must be specified by the customer and includes: minimum and maximum flow ranges, pipe I.D. and O.D. or wall thickness, 20" O.D. max. (Consult factory for larger diameter), position of meter (horizontal, inclined), temperature of meter environment, indicator scale and units, totalizer dial units, type of materials and construction, and optional equipment desired.

**MODEL LP32**

150 psi STRAP-ON SADDLE METER  
 SEALED METER MECHANISM - MAGNETIC DRIVE  
 STAINLESS STEEL STRAP-ON SADDLE  
 INDICATOR-TOTALIZER  
 SIZES 6" thru 20"

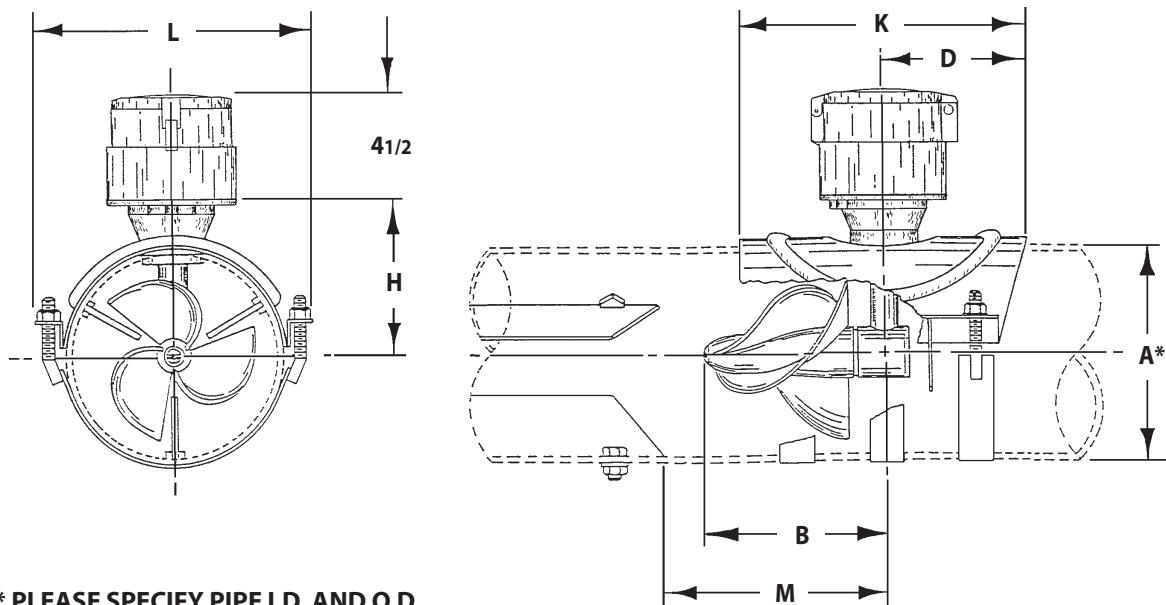

\* PLEASE SPECIFY PIPE I.D. AND O.D.

METER & PIPE SIZE	FLOW RANGES, GPM			DIMENSIONS						SHIPPING WEIGHT POUNDS	
	MIN.	MAX.	INT.	A	B	D	H	K	L		
6	200	1200	1500	6 <sup>5</sup> / <sub>8</sub>	8	6	5 <sup>1</sup> / <sub>4</sub>	12	13	10	20
8	250	1500	2000	8 <sup>5</sup> / <sub>8</sub>	8	6	6 <sup>1</sup> / <sub>4</sub>	12	12 <sup>1</sup> / <sub>2</sub>	10	25
10	300	2000	3000	10 <sup>3</sup> / <sub>4</sub>	8	6	7 <sup>3</sup> / <sub>8</sub>	12	13 <sup>1</sup> / <sub>4</sub>	10	28
12	350	3000	3500	12 <sup>3</sup> / <sub>4</sub>	8	6	8 <sup>3</sup> / <sub>8</sub>	12	15 <sup>1</sup> / <sub>4</sub>	10	32
14	450	4000	4500	14	8	6	9 <sup>1</sup> / <sub>4</sub>	12	15 <sup>1</sup> / <sub>2</sub>	10	35
16	500	5000	6000	16	8	6	10 <sup>1</sup> / <sub>4</sub>	12	17 <sup>1</sup> / <sub>2</sub>	10	38
18	800	6000	7500	18	8	6	11 <sup>1</sup> / <sub>4</sub>	12	19 <sup>1</sup> / <sub>2</sub>	10	43
20	950	8000	9000	20	8	6	12 <sup>1</sup> / <sub>4</sub>	12	21 <sup>1</sup> / <sub>2</sub>	10	49



www.mccrometer.com

3255 WEST STETSON AVENUE • HEMET, CALIFORNIA 92545 USA  
 TEL: 951-652-6811 • FAX: 951-652-3078

Copyright © 2019 McCrometer. All printed material should not be changed or altered without permission of McCrometer. The published technical data and instructions are subject to change without notice. Contact your McCrometer representative for current technical data and instructions.