



# **6"-20" STRAP-ON ELECTRONIC LOW PRESSURE METERS**

**MODEL  
LP04D, LP12D, LP32D**

## **OPERATION AND MAINTENANCE MANUAL PARTS LIST**

**FEATURING:**

- \* CERAMIC BEARING CARTRIDGE
- \* STAINLESS STEEL SADDLE & U-STRAP
- \* MODEL FC101 FLOWCOM REGISTER INDICATOR-TOTALIZER
- \* ONE PIECE SEPARATOR/SPINDLE AND THREADED REVERSE THRUST BEARING CARTRIDGE



**3255 WEST STETSON AVENUE  
HEMET, CALIFORNIA 92545 U.S.A.**

**PHONE: 951-652-6811  
FAX: 951-652-3078  
VISIT OUR WEBSITE: [www.mccrometer.com](http://www.mccrometer.com)**

## WARRANTY

This Warranty shall apply to and be limited to the original purchaser consumer of any McCrometer product. Meters or instruments defective because of faulty material or workmanship will be repaired or replaced, at the option of McCrometer, free of charge, FOB the factory in Hemet, California, within a period of one (1) year from the date of delivery.

Repairs or modifications by others than McCrometer or their authorized representatives shall render this Warranty null and void in the event that factory examination reveals that such repair or modification was detrimental to the meter or instrument. Any deviations from the factory calibration require notification in writing to McCrometer of such recalibrations or this Warranty shall be voided.

In case of a claim under this Warranty, the claimant is instructed to contact McCrometer, 3255 W. Stetson Ave., Hemet, California 92545, and to provide an identification or description of the meter or instrument, the date of delivery, and the nature of the problem.

The Warranty provided above is the only Warranty made by McCrometer with respect to its products or any parts thereof and is made expressly in lieu of any other warranties, by course of dealing, usages of trade or otherwise, expressed or implied, including but not limited to any implied warranties of fitness for any particular purpose or of merchantability under the uniform commercial code. It is agreed this Warranty is in lieu of and buyer hereby waives all other warranties, guarantees or liabilities arising by law or otherwise. Seller shall not incur any other obligations or liabilities or be liable to buyer, or any customer of buyer for any anticipated or lost profits, incidental or consequential damages, or any other losses or expenses incurred by reason of the purchase, installation, repair, use or misuse by buyer or third parties of its products (including any parts repaired or replaced); and seller does not authorize any person to assume for seller any other liability in connection with the products or parts thereof. This Warranty cannot be extended, altered or varied except by a written instrument signed by seller and buyer.

This Warranty gives you specific legal rights, and you may also have other rights which vary from state to state.

McCrometer reserves the right to make improvements and repairs on product components which are beyond the Warranty period at the manufacturer's option and expense, without obligation to renew the expired Warranty on the components or on the entire unit. Due to the rapid advancement of meter design technology, McCrometer reserves the right to make improvements in design and material without prior notice to the trade.

All sales and all agreements in relation to sales shall be deemed made at the manufacturer's place of business in Hemet, California and any dispute arising from any sale or agreement shall be interpreted under the laws of the State of California.

## ELECTRONIC LOW PRESSURE METER INDEX

- I. UNCRATING**
- II. INSTALLATION**
  - 1. Flanged Tube Meters
  - 2. Plain End Tube Meters
  - 3. Strap-On Saddle Meters
    - A. Align
    - B. Mark
    - C. Scribe
    - D. Cut Out
    - E. Straightening Vanes
    - F. Meter Assembly
- III. INSTRUCTION AND MAINTENANCE MANUAL**
- IV. METER SADDLE ASSEMBLY**
- V. WORKING AREA**
- VI. DISASSEMBLY & INSPECTION**
  - 1. Propeller Removal
  - 2. Reverse Thrust Bearing Cartridge
  - 3. Water Lubrication
  - 4. Ceramic Bearing Cartridge
  - 5. Spindle Ceramic Sleeve
  - 6. Separator/Support Spindle Assembly
- VII. REASSEMBLING METER**
  - 1. Propeller Installation
  - 2. Thrust Bearing Cartridge Assembly
  - 3. Propeller Bearing
- VIII. SENSOR & FC101 DIGITAL INDICATOR-TOTALIZER**
  - 1. FC101 Digital Indicator
  - 2. FC101 Removal
  - 3. Sensor Housing
  - 4. Replacing Sensor Housing
  - 5. Inspect O-ring
  - 6. Lithium Battery
  - 7. FC101 Digital Indicator-Totalizer
- IX. PREPARATION PRIOR TO INSTALLING METER**
  - 1. Propeller Assembly
  - 2. FC101
  - 3. Meter Saddle D-ring
- X. ORDERING PARTS OR RETURN TO FACTORY**

## ELECTRONIC LOW PRESSURE METER INSTALLATION

**I. UNCRATING.** When uncrating the meter, any damage due to rough or improper handling should be reported to the transportation firm and McCrometer. If for any reason it is determined that the unit or parts of the unit should be returned to the factory, please contact McCrometer for clearance prior to shipment. Each unit must be properly crated to prevent any further damage. The factory assumes no responsibility for equipment damage in return shipment due to improper packaging. The shipping crate contains the following items:

|   |   |
|---|---|
| Low Pressure Meter Assembly with FC101..... | 1 |
| Mounting Equipment as required.....         | - |
| Operation and Maintenance Manual.....       | 1 |
| Tool T-2402X-1.....                         | 1 |

**II. INSTALLATION** of McCrometer Low Pressure Electronic Meters varies depending upon the type and model of meter selected for each application. The meter must have a full flow of liquid for proper accuracy. Fully opened gate valves, fittings or other obstructions that tend to set up flow disturbances should be a minimum of ten pipe diameters upstream and two pipe diameters downstream from the meter. Installations with less than ten pipe diameters of straight pipe require straightening vanes. Meters with straightening vanes require at least five pipe diameters upstream and one pipe diameter downstream from the meter. The meter installations fall into three basic categories:

1. **FLANGED TUBE METERS** can be installed exactly as you would install any short length of flanged pipe. Flanged ends are standard pattern and drilling for any meter size.

2. **PLAIN END TUBE METERS** can be installed similar to replacing a short length of plain end pipe in the line by either welding, or by using one of a variety of pipe couplings available. **Note:** Meter saddle assembly (#23) should be removed before welding. (See step IV.)

3. **STRAP-ON SADDLE METERS** can be installed on an existing pipeline by cutting a hole of proper size in the existing pipeline. The installation steps outlined below should be followed carefully to achieve proper mounting of the meter:

**A. ALIGN** the cutout template in the desired position for the meter on the pipe. Make certain that the center line of the pipe and the center line marked on the template are parallel with each other.

**B. MARK** the pipe using a center punch as indicated on the cutout template. These marks will help to properly align the saddle over the cutout opening.

**C. SCRIBE** the pipe along the line specified for your meter size cutout.

**D. CUT OUT** the section of pipe within the scribed line and remove all burrs, slag, and rough edges from the inside and outside of the cutout section.

**E. STRAIGHTENING VANES** are recommend when there are less than ten pipe diameters of straight pipe (no fittings or obstructions) directly upstream from the meter location. Straightening vanes are available from the factory. (See Straightening Vane Installation Instructions if required for your meter.)

**F. METER ASSEMBLY** should be placed on the pipe with the "D" shaped ring gasket in position on the bottom of the saddle. The saddle must be positioned so that the D-ring maintains contact with the surface of the pipe completely around the cutout opening. Align the centerline of the saddle with centerline of the pipe and locate the saddle so that it is exactly between, and aligned with, the center punch marks on the pipe. Each edge of the meter saddle should be approximately 1/8" from the center punch mark on the pipe. U-Strap nuts should be tightened evenly. **WARNING:** Customers are warned that the U-Strap nuts are to be tightened evenly to approximately 30 foot pound torque. This is sufficient to seal the saddle to the pipeline. Additional tightening may be required to seal the saddle on rough or irregular pipe.

#### ELECTRONIC LOW PRESSURE METER INSTRUCTION AND MAINTENANCE MANUAL

**III. MCCROMETER** products have been carefully designed to be as maintenance free as possible. Periodic preventive maintenance, however, is highly recommended and should be practiced according to schedule to assure continuous accuracy and trouble-free performance of your propeller meters. The maintenance and inspection procedure can also be used as a guide to locating a problem in the unit that may be the cause of abnormal meter operation.

Routine preventative maintenance should be performed on all meters, which includes cleaning and an inspection of the propeller and its bearing. The interval between inspections depends on the water quality and the usage of the meter. The initial inspection should be performed after one to two years of service to determine the period between future inspections. After five to ten years, the complete meter should be inspected to ensure years of dependable service.

**IV. METER SADDLE ASSEMBLY (#23)** should be removed from the service line by removing the U-strap nuts (#27) and lifting up the rear (downstream) portion of the meter saddle (#23), carefully pulling the assembly back (downstream) and up at the same time to allow the propeller (#2) to clear the cutout opening in the pipeline so the

meter can be lifted free. Inspect the meter saddle D-ring (#22) for any sign of damage and replace, if necessary. Replace the meter assembly (#23) with a dummy cover saddle if the service line is to remain in operation.

**V. WORKING AREA** chosen for disassembly and reassembly of the meter components should be clean to reduce the chance of dust or dirt particles being introduced into the propeller area.

**VI. DISASSEMBLY AND INSPECTION OF METER** includes cleaning the propeller assembly (#1), ceramic sleeve bearing (#8), separator assembly (#12) and drive magnet (#9).

**1. PROPELLER REMOVAL** can be accomplished by first removing the thrust bearing cartridge assembly (#5). Loosen the set screw (#3) in the side of the nose of the propeller. Remove the thrust bearing cartridge (#5) by turning it counterclockwise while holding the propeller in place.

**2. REVERSE THRUST BEARING CARTRIDGE (#6)** must now be removed. Turn the propeller (#2) so that the Allen wrench clearance hole is lined up with the set screw in the side of the reverse thrust bearing cartridge (#6). The location of the set screw is marked by a small hole drilled in the face of the reverse thrust bearing cartridge. With a 5/64 inch Allen wrench, loosen the set screw (#7) in the reverse thrust bearing cartridge (#6) two to three turns, which will allow the cartridge to be unscrewed without damaging the spindle thread. **Note:** If the bearing area appears to be clogged with dirt or sediment, making it difficult to locate the set screw (#7) or to allow the Allen wrench to fit into the set screw socket, then the bearing area should be flushed out with water. Insert Tool T-2402X-1 into the propeller through the threaded nose. The tabs in the tool should engage in the screwdriver slot in the end of the reverse thrust bearing cartridge (#6). Remove the propeller assembly (#1) and reverse thrust bearing cartridge (#6) by turning Tool T-2402X-1 counterclockwise, unscrewing the reverse thrust bearing cartridge (#6) from the spindle (#12). The propeller assembly with reverse flow cartridge will now slide off the spindle. **WARNING:** If the reverse thrust cartridge does not unscrew easily, it may be because the set screw was not unscrewed enough. If unscrewing the reverse flow cartridge is continued with the set screw binding on spindle thread, damage to thread could occur.

**3. WATER LUBRICATION** of the ceramic sleeve bearing (#8) is achieved by means of two openings in the end of the thrust bearing cartridge (#5) which allows air to be purged from the bearing area. These should be cleared of any foreign material by running a small wire through the holes on either side of the screwdriver slot.

**4. CERAMIC BEARING CARTRIDGE (#8)** and drive magnet (#9) should be cleaned of any foreign material and inspected for damage. Using a bottle brush, thoroughly clean the ceramic bearing surface (#8) and the magnet inside diameter (#9). After cleaning the propeller, flush the inside out with water. The outside surfaces of the propeller should also be cleaned to assure a smooth, unrestricted flow across the surface of the propeller. Do not use an oil-based solvent in cleaning, as damage to the assembly could occur.

**5. SPINDLE CERAMIC SLEEVE** and the O.D. or surface of the separator should be cleaned and inspected for any substantial amount of wear. The reverse thrust bearing (#6) should be checked for any damage. If it is determined that the spindle ceramic sleeve or separator are worn sufficiently, the separator/support spindle assembly (#12) should be replaced.

**6. SEPARATOR / SUPPORT SPINDLE ASSEMBLY (#12)** can be removed for replacement by removing the four mounting screws (#13) which thread into the gearbox. The separator O-ring (#14) should be replaced and the new O-ring (#14) covered with a thin coat of silicone grease. The separator/support spindle assembly (#12) can then be replaced in the front of the gearbox (#16) with a firm push, gently rotating the assembly at the same time. Replace and tighten the four mounting screws (#19).

## VII. REASSEMBLING METER

**1. PROPELLER INSTALLATION** is accomplished by following these steps:

a) The reverse thrust cartridge set screw (#7) should be protruding out of the reverse thrust bearing cartridge so it will not bind up on the spindle thread. **Note:** Look through the end of the propeller and hole in the reverse thrust cartridge to be sure the set screw is not showing.

b) Slide the propeller assembly onto the support spindle (#12) until the reverse thrust bearing cartridge (#6) contacts the threads on the end of the spindle (#12). Using Tool T-2402X-1, thread the reverse thrust bearing cartridge onto the spindle. If you feel any resistance when threading the reverse thrust cartridge on, stop at once and check to be sure the set screw is not binding on the thread. Be careful not to cross-thread the reverse thrust bearing cartridge. Thread the reverse thrust bearing cartridge (#6) onto the spindle (#12) until the trailing edge of the propeller contacts the gearbox (#16). Set the proper end play by inserting a 5/64" Allen wrench into the reverse thrust bearing set screw (through the side of the propeller) and loosening the reverse thrust bearing cartridge (#6) one half turn counterclockwise. Tighten the set screw in reverse thrust bearing cartridge. There should be approximately .02" clearance

between the gearbox (#16) and trailing edge of the propeller when the propeller is pulled forward (away from the gearbox). The propeller must not contact the gearbox.

**2. THRUST BEARING CARTRIDGE ASSEMBLY (#5)** should be inspected for damage and replaced in the nose of the propeller. The thrust bearing cartridge (#5) is used to adjust the amount of longitudinal end play of the propeller assembly on its spindle (#12), which should be about 1/64 inch. End play can be adjusted by turning the thrust bearing cartridge assembly (#5) clockwise until it tightens against the end of the support spindle (#12), then turning thrust bearing cartridge (#5) counterclockwise 1/8 of a turn. Tighten set screw (#3). Check the longitudinal end play of the propeller to insure it's not excessive and does not allow the propeller (#2) to contact the gearbox (#16). Check the clearance between the propeller (#2) and gearbox (#16). The clearance should be approximately .01" between the gearbox (#16) and trailing edge of the propeller when the propeller is pushed back (toward the gearbox). The propeller assembly (#1) must spin freely.

**3. PROPELLER BEARING (#1)** can be checked for excessive radial play by rocking the propeller (#2) gently from side to side on the spindle (#12). Some play is required for proper operation of the water lubricated ceramic sleeve bearing.

## VIII. SENSOR AND FC101 DIGITAL INDICATOR-TOTALIZER

**1. FC101 DIGITAL INDICATOR (#34)** should not be removed from the meter unless battery or sensor replacement is required. If the unit must be removed, proceed as follows:

**2. FC101 (#34)** can be removed from meter head by removing the four screws (#32) then slightly lifting unit up and turning over to disconnect the 2-lead sensor wires from the bottom of the FC101. If the meter is equipped with a transmitter, the transmitter wires must also be disconnected.

**3. SENSOR HOUSING** should be removed only if replacement is necessary. The sensor can be taken out of the separator after removing the gearbox backplate (#17). Once the backplate is removed, pull the sensor wire and sensor assembly out of the back of the gearbox.

**4. BEFORE REPLACING THE SENSOR** be sure the separator is dry. Slide sensor housing and wire assembly into the separator until it stops against the inside of separator. **Note:** It does not make any difference what rotation position sensor is installed, however, wire must be positioned toward back (open end) of separator. Feed the sensor wire up through the gearbox and out the meter head.

**5. LITHIUM BATTERY** should offer 6 to 10 years of operation. The FC101 has a low battery display that comes on when approximately six months of life is remaining. The battery should test at least 2.8 to 3.6 volts to be considered good. **NOTE: Batteries should be disposed of in an environmentally safe manner.**

**6. THE FC101 DIGITAL INDICATOR-TOTALIZER (#34)** can now be installed in one of four positions for more convenient reading with four screws (#32).

**IX. PRIOR TO INSTALLING METER**

**1. PROPELLER ASSEMBLY (#1)** should be dipped in water to lubricate the propeller ceramic sleeve bearing (#8). Spin the propeller (#2) gently to make certain the meter operates smoothly and no bind or drag is apparent.

**2. FC101 (#34)** and sensor (#15) should be checked to be sure they are connected and that the battery is good. Turn the propeller by hand at a fairly fast even speed and the indicator should display a flow rate.

**3. METER SADDLE D-RING (#22)** should be inspected for any sign of damage and covered with a thin coat of silicone grease. The meter can now be installed in the service line. (See step II-F for proper installation.) When replacing the meter on the line, make certain that the top of the pipeline is smooth and free of any foreign material. Make certain that no foreign materials are attached to the inside of the service line pipe, as any flow disturbance or obstruction may affect the accuracy of the meter.

**X. ORDERING PARTS OR RETURN TO FACTORY**

Inspection of all meter components that may be replaced in the field has been accomplished at this point. Should any of the meter parts, upon inspection, appear to be damaged or excessively worn, they must be replaced to assure proper meter operation and prevent further damage. Cost for replacement parts not covered by warranty are available by contacting the factory. If it is determined that the meter should be returned for repair, please notify McCrometer prior to shipment. Each meter must be properly packaged to prevent damage to the meter in shipment.

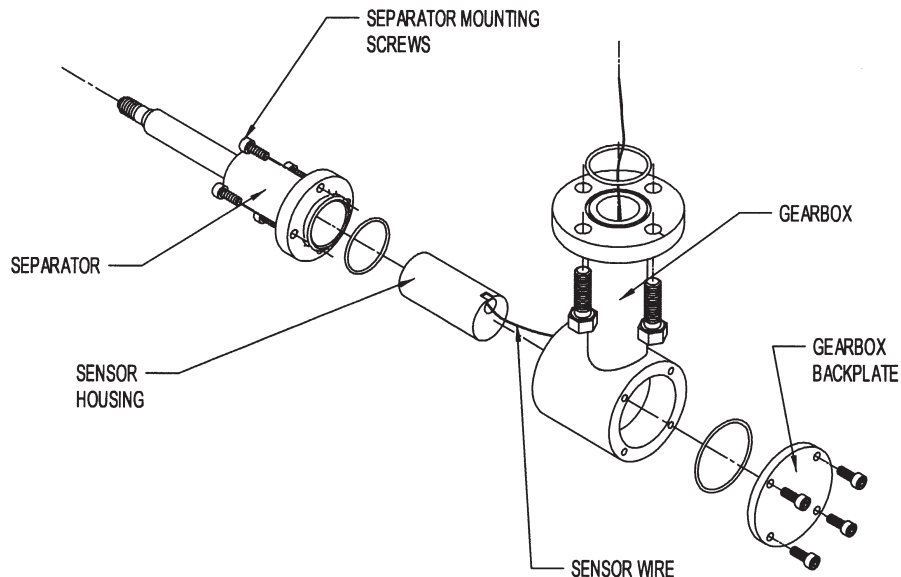

**NOTES**

**6"-20" STRAP-ON LOW PRESSURE METERS  
MODEL LP04D, LP12D, LP32D  
PARTS LIST**

| No.  | QTY | Part Number      | Description  |
|------|-----|------------------|--|
| none | 1   | 7-MLI1D-*        | Model MLI1D Main Line Meter Head Assembly                  |
| 1    | 1   | 5-2425-‡-PT      | Propeller Assembly (Items 2 thru 8)                        |
| 2    | 1   | 3-2425-‡-P       | Propeller  |
| 3    | 1   | 1-1125-6         | Set Screw, Nylon Point                                     |
| 4    | 1   | 1-1116-8-6       | Screw, Bearing Cartridge Mounting                          |
| 5    | 1   | 3-2356           | Thrust Bearing Cartridge Assembly                          |
| 6    | 1   | 3-2402-2         | Reverse Thrust Bearing Cartridge Assembly (Items 6 and 7)  |
| 7    | 1   | 1-1101-8-5       | Set Screw, Reverse Thrust Bearing                          |
| 8    | 1   | 2-2426-P-1       | Ceramic Bearing Cartridge                                  |
| 9    | 1   | 2-1601-2         | Drive Magnet   |
| 10   | 1   | 1-2428-‡         | Drive Magnet Retaining Plate                               |
| 11   | 2   | 1-1115-3-18      | Screw, Magnet Retaining Plate (each)                       |
| 12   | 1   | 4-2455-2         | Separator/Support Spindle Assy                             |
| 13   | 4   | 1-1103-8-7       | Screw, Separator/Spindle Mounting (each)                   |
| 14   | 1   | 1-1551-24        | O-ring, Separator  |
| 15   | 1   | 4-2730-3-‡       | Sensor Housing, Sensor and Wire Assembly                   |
| 16   | 1   | 3-2394-*-304     | Gearbox  |
| 17   | 1   | 2-2731           | Gearbox Backplate  |
| 18   | 1   | 1-1551-2         | O-ring, Gearbox Backplate                                  |
| 19   | 4   | 1-1103-8-7       | Screw, Gearbox Backplate Mounting (each)                   |
| 20   | 4   | 1-1251-5-12      | Bolt, Gearbox Mounting (each)                              |
| 21   | 1   | 10110-10         | O-ring, Gearbox  |
| 22   | 1   | 1-1552-23        | D-Ring Meter Saddle  |
| 23   | 1   | 3-2414-‡‡        | Meter Saddle Assembly                                      |
| 24   | 1   | 1-1551-25        | O-Ring, Meter Head - Outer                                 |
| 25   | 1   | 1-1551-50        | O-Ring, Meter Head - Inner                                 |
| 26   | 1   | 1-2441           | Meter Head (Sizes 6" thru 20")                             |
| 27   | 6   | 1-1211-1         | Nut, U Strap (each)  |
| 28   | 6   | 1-1301-14        | Washer, U Strap Bolt (each)                                |
| 29   | 3   | 3-2437-*         | U Strap Assembly (each)                                    |
| 30   | 1   | 1-1707-19 or -20 | InLine Terminal (19) 2 Wire (-20) 3 Wire For Remote        |
| 31   | 1   | 1-1551-38        | O-Ring - 243 Buna  |
| 32   | 4   | 10605            | Screw 10-32 x 1.25" Long                                   |
| 33   | 1   | FC101-M          | Magnet Wand  |
| 34   | 1   | FC101-*          | FC101 Flowcom Ind.-Tot. & Bonnet Complete - See IOM Manual |
| none | 1   | 10015-00K        | Desiccant Bag  |
|      |     |                  |  |
|      |     |                  |  |
|      |     |                  |  |
|      |     |                  |  |

\*Insert meter size to complete part number - for example:

use -06 for 6", -08 for 8", etc.)

‡Consult factory to complete part number

‡‡Insert -06 for 6"; -08 for 8" - 20"

When ordering replacement parts, please specify:

• Meter Size • Meter Model • Meter Serial Number  
Contact Factory For Pricing.



# 6"-20" STRAP-ON LOW PRESSURE METERS

MODEL LP04D, LP12D, LP32D

\*MODEL FC101 INDICATOR-TOTALIZER ASSEMBLY

\*CERAMIC BEARING CARTRIDGE PROPELLER

\*ONE PIECE SEPARATOR/SPINDLE & THREADED REVERSE THRUST BEARING CARTRIDGE

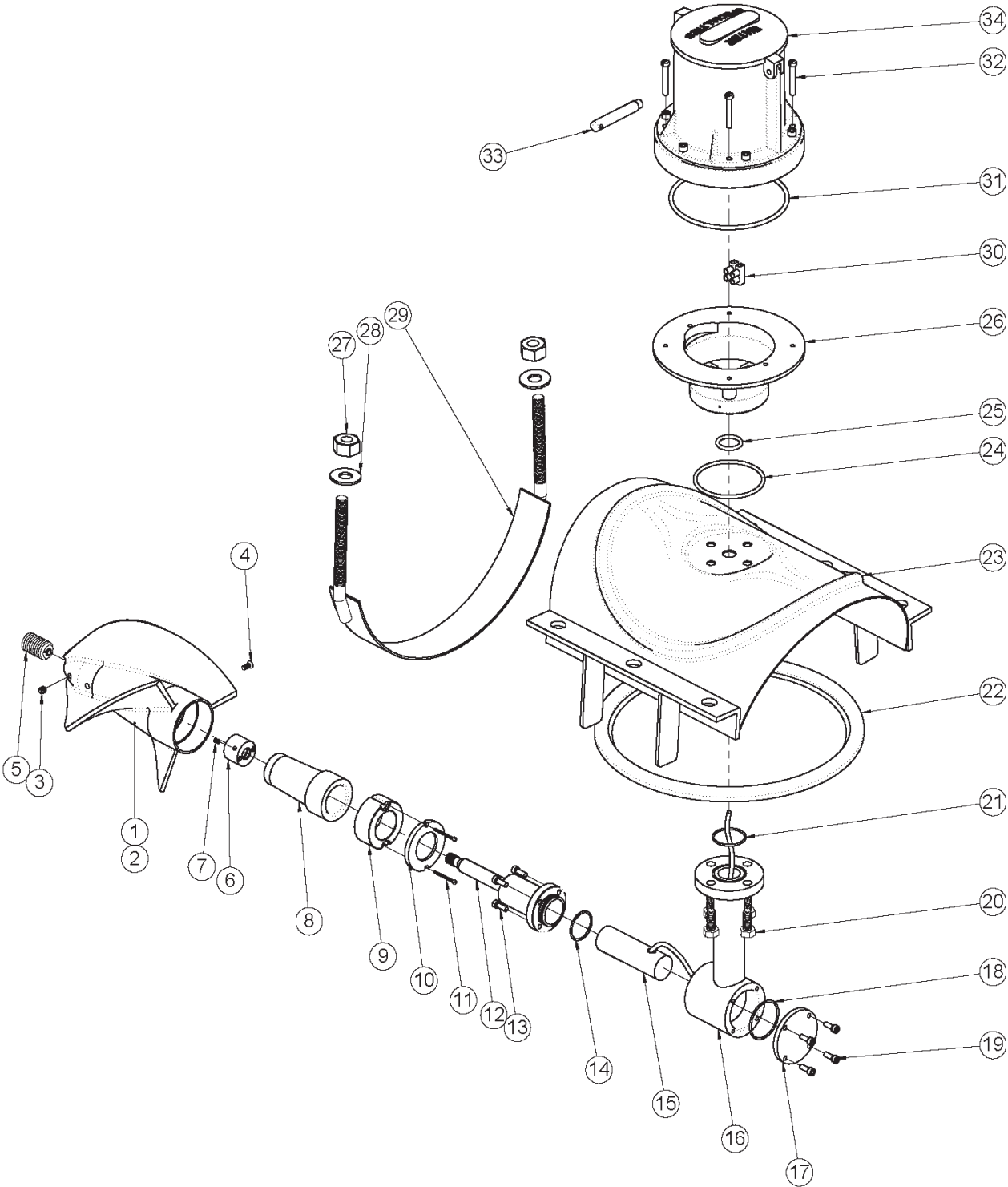

**WARNING:**

**BEFORE REMOVING THE METER SADDLE FROM THE PIPELINE THE WATER MUST BE TURNED OFF AND PRESSURE MUST BE RELIEVED FROM THE LINE. SERIOUS INJURY CAN RESULT FROM REMOVING A METER SADDLE UNDER PRESSURE.**