



**Liquid & Gas Flow Measurement  
For Oil/Gas FPSO Vessels**

---

***White Paper***

# White Paper

By Marcus Davis  
V-Cone Product Manager  
McCrometer, Inc.

## Liquid & Gas Flow Measurement For Oil/Gas FPSO Vessels

To meet the global demand for oil/gas production, Floating Production, Storage, & Offloading (FPSO) Vessels have been utilized for a number of years to access deep water deposits. They process oil from subsea wells and/or completions and store it until it can be offloaded onto waiting tankers or sent through a pipeline to other storage facilities onshore or refineries, etc.

The productivity, flexibility and cost advantages of FPSO Vessels have made them increasingly popular within the oil/gas industry. They continue to grow in number and are in use in many of the world's major offshore production fields.

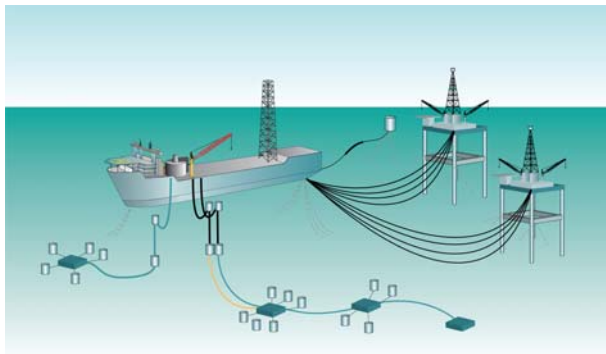

Figure 1: Subsea Overview

Liquid and gas flow meters play an important role in FPSO Vessel operations by measuring hydrocarbons, water and gas at multiple points in the process.

FPSO Vessels can be newly constructed, retrofitted from a decommissioned oil tanker or other vessel, or an existing FPSO can be reworked for redeployment. They are usually connected by mooring buoy and accumulate oil until there is a sufficient amount to fill a transport tanker, at which point the transport tanker connects to the stern of the floating storage unit and offloads the oil.



Figure 2: FPSO Vessel & V-Cone

### FPSO Flow Meter Applications

There are multiple applications on FPSO vessels for flow meters, which the industry

classifies as top-side instrumentation. The topsides environment aboard FPSO vessels includes many flow meter applications involving liquid, steam and gas during the separation process. The following vessel operation applications require flow meters:

- Separators: Test & Production; gas & gas/liquids (hydrocarbons, water), and produced water
- Gas or Water Reinjection
- CO2 Injection (sequestration); both onshore and offshore
- CO2 Removal.
- Glycol(s) Injection
- Methanol Injection
- Gas Lift
- Field Production Transmission Lines
- Surge Control; compressors; may be more than one based on how many compression stages there are on the system
- Flare Gas Feed Lines
- Fuel Gas
- Fire Water
- Other specialized packages that may be necessary to treat and process fluids unique to a particular field

## The Application Challenges

In addition to normal considerations for selecting a flow meter such as accuracy and repeatability, FPSO vessel builders and operators are highly space constrained. There is only so much shipboard real estate available for vessel equipment. When equipment such as flow meters need long pipe upstream/downstream straight runs to condition the fluid for accurate measurement, the required space for straight pipe runs and their substantial extra weight adds unnecessary complications.

In order to obtain the required space for straight pipe runs, vessel builders must juggle moving other equipment to accommodate the additional piping. This usually leads to a domino effect whereby other pieces of equipment must be rearranged as well. This rearrangement compounds over and over creating complicated layouts not to mention the additional weight and space of extra piping. The added weight required by additional piping and complex layouts further complicates other considerations such as transportation and installation. Transportation costs increase dynamically and logistics become more rigorous.

Turndown, maintenance and life expectancy are critical in the dynamic, harsh and inaccessible seabound operating environment where equipment is designed to last 25 years or more with no maintenance. While the general oil/gas industry requires good accuracy and repeatability over a wide flow range, FPSO vessels require tighter standards over a longer life with consistent accuracy and repeatability. It is imperative that equipment installed on FPSO vessels is reliable over a long life.

Although several flow meter technologies meet these requirements, nearly all require an average of 10 or more diameters straight pipe upstream and 1 to 5 diameters straight pipe downstream from the meter to condition the flow for measurement. Elbows, valves, compressors, and other equipment in the pipeline disturb the fluid flow creating swirls and irregularities that degrade flow meter measurement accuracy. In crowded FPSO vessels, the addition of 10 to 15 diameters of heavy space-consuming straight pipe for each flow meter is a major issue in terms of real estate, weight and cost.

## The Solution

The ability to eliminate long required straight pipe runs for flow meter technologies while meeting necessary technical specifications reduces installation real estate and allows for flexible layouts while cutting overall pipe weight, material and installation costs. McCrometer's uniquely designed differential pressure V-Cone® Flow Meter is now frequently utilized by the industry's major FPSO Vessel builders and operators.

The V-Cone utilizes a centrally located intrusion that redirects the flow to the outside of the pipe and conditions the flow by reshaping the velocity profile, all but eliminating the need for straight pipe runs.

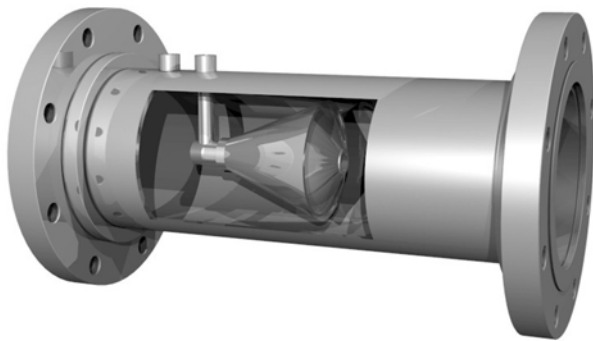

Figure 3: V-Cone Flowmeter Cutaway

The V-Cone requires straight pipe runs of only 0 to 3 pipe diameters upstream and 0 to 1 pipe diameters downstream. This smaller footprint, requiring up to 70% less straight pipe without being affected by flow disturbing equipment up or down stream, is more compact than any other differential pressure meter suitable for subsea use. This allows manufacturers to place the flow meter exactly where it's needed without the costly addition of extra pipe and complicated space consuming layouts.

The V-Cone measures fluid flow by utilizing the conservation of energy theory,

which basically states that in a closed system, energy can be neither gained nor lost. With this in mind we can utilize the  $PV=nRT$  equation where pressure multiplied by volume equals temperature while  $n$  and  $R$  are constants. Therefore, imposing a volume change within the pipe line results in a differential pressure drop that can be measured directly.

The V-Cone places a "V-shaped" conical intrusion centrally in the line redirecting the fluid to the outside of the pipe and around the cone. One pressure sensing tap located upstream from the cone measures static pressure while another pressure sensing tap measures the low pressure created by the cone on the downstream face of the cone itself. This pressure difference is incorporated into a derivation of the Bernoulli equation to determine fluid flow. As the fluid moves past the cone, very short vortices are formed that result in a low-amplitude, high-frequency signal optimal for excellent signal stability.

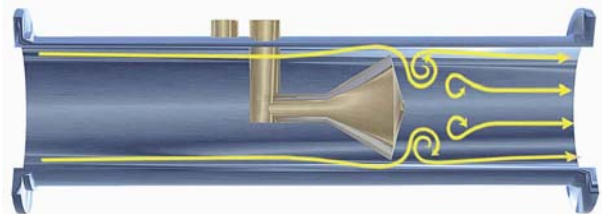

Figure 4: Vortices Created By The V-Cone

The V-Cone maintains  $\pm 0.5\%$  accuracy and  $\pm 0.1\%$  repeatability over a 10 to 1 turndown and the cone conditions the fluid such that there is relatively low permanent head loss.

Low permanent head loss achieved by the V-Cone results from the shape of the cone itself, which minimizes energy losses commonly caused by areas of low flow, cavitation and erratic flows. Each V-Cone is sized to meet desired application requirements and may be specifically

designed to have high or low head loss. Regardless, the overall energy consumed by the V-Cone is minimized because of its inherent characteristics.

The rugged, no moving parts V-Cone measures abrasive, dirty, and particle-laden fluids over a wide range of Reynolds numbers without wear or clogging concerns, resulting in an unprecedented standard 25 year operating life with generally no need for maintenance. Reynolds numbers are a measure of whether flow is laminar or turbulent.

The turbulent vortices produced by the V-Cone condition the fluid flow to be homogeneously distributed and extremely stable. It is this turbulent flow that actually protects the cone as well as the surrounding pipe. The turbulent flow forms a boundary layer against the pipe wall and cone protecting it from particle impingement which can cause deterioration or buildup on the surfaces.

Normal surface deterioration in flow meters, piping, and other equipment occurs as a result of fluid shear stress. Shear stress creates a problem where there is a solid boundary layer in direct contact with the walls of the pipe. Shear stress occurs in laminar and unstable turbulent flows.

The V-Cone's very stable turbulent flow all but eliminates this shear stress and consequently results in no surface deterioration. Additionally, due to the shape of the cone, there is little chance of cavitation on the backside of the cone to erode the surface. Each V-Cone is calibrated during the manufacturing process and because the design is so robust, there is never a need for regular maintenance or recalibration after installation.

Given the substantial distances between the subsea well head, the FPSO vessel and the final shipboard destination of the fluid being moved, the V-Cone's low permanent head loss results in much lower energy requirements to move the product. Cavitation, eddies, and areas of zero flow that can form on the downstream side of differential pressure devices are actually energy consumers. This energy loss directly equates to the need for larger pumps to move the desired amount of fluid.

## **The Results**

FPSO vessel applications require what McCrometer's V-Cone Flow Meter has to offer: stable operation at internal pressures up to ANSI 15,000 psi, no moving parts, no wear along the beta edge or pipe resulting in no need for physical calibration, high accuracy and repeatability over a long life, and small weight and space footprint. The V-Cone Flow Meter supports line sizes from 0.5 to 120 inches or greater with most types of end connections, can be manufactured out of almost any material and to almost any pressure rating.