

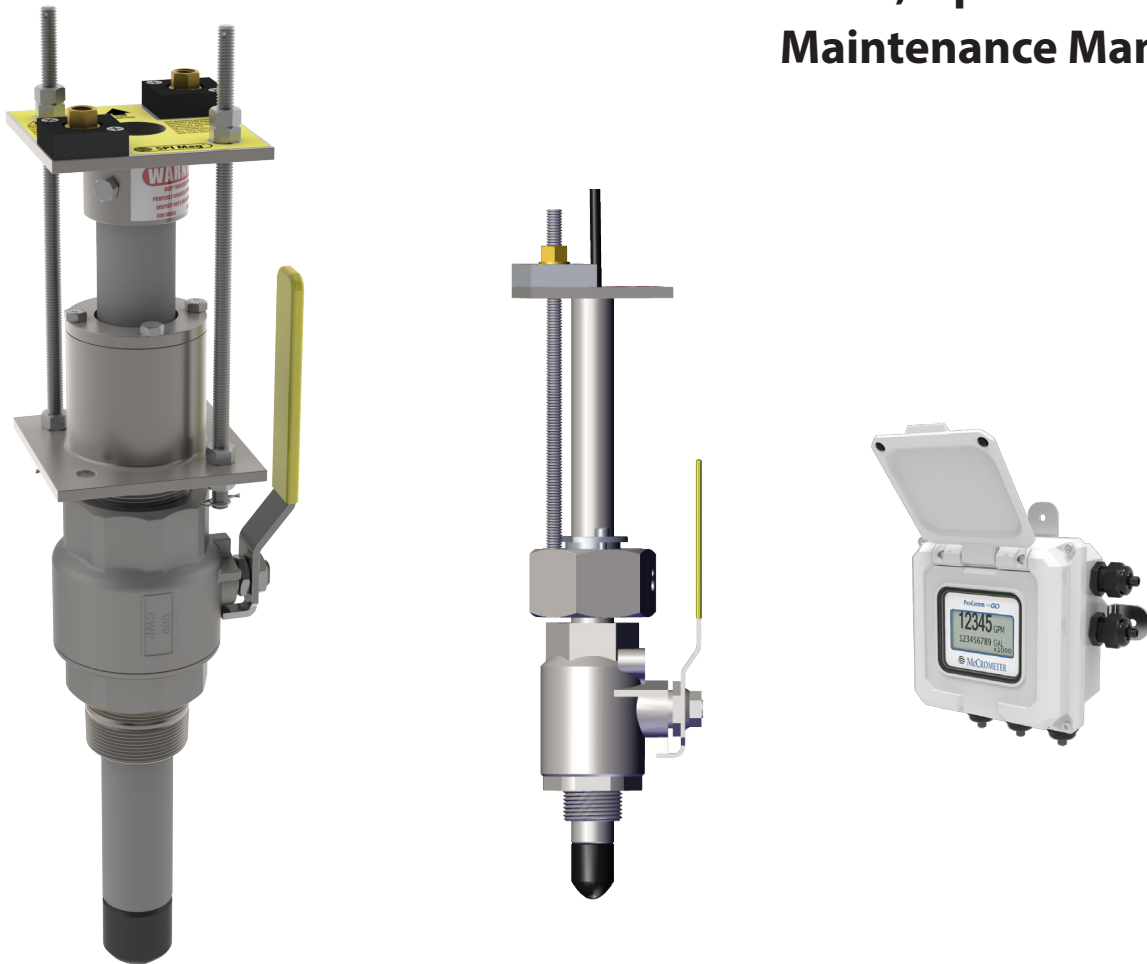

SPI Mag 3000 Single Point Insertion Electromagnetic Flow Meter 1" and 2" Sensors

Installation, Operation and Maintenance Manual



30126-41 Rev. 1.0
26AUG2024

Contents

1.0	SAFETY SYMBOLS AND WARNINGS	1
1.1	Safety Symbols	1
1.2	Safety Warnings.....	1
2.0	SPI MAG DESCRIPTION OF COMPONENTS	2
2.1	Overview	2
2.2	Flow Calculation	3
2.3	Profiling Information	3
2.4	Full Pipe Sensors	3
3.0	PARTS DIAGRAMS	4
4.0	SENSOR PROBE INSTALLATION	5
4.1	Site Selection	5
4.2	Sensor Clearance	5
4.3	Pipe Valve Installation	6
4.4	Sensor Assembly Installation	6
4.5	Inserting The Sensor.....	7
4.6	Clean Water Sensor Position	7
4.7	Raw Water Sensor Position	8
4.8	Sensor Insertion Tool	8
5.0	SENSOR REMOVAL	9
6.0	MAINTENANCE	9
7.0	SPECIFICATIONS	10
8.0	SPI MAG ORDERING INFORMATION	14
9.0	CONVERSION TABLES	15
	WARRANTY STATEMENT	16

1.0 SAFETY SYMBOLS AND WARNINGS

1.1 Safety Symbols

Throughout this manual are safety warning and caution information boxes. Each warning and caution box will be identified by a large symbol indicating the type of information contained in the box. The symbols are explained below:



This symbol indicates important safety information. Failure to follow the instructions can result in serious injury or death.



This symbol indicates important information. Failure to follow the instructions can result in permanent damage to the meter or installation site.

1.2 Safety Warnings

When installing, operating, and maintaining McCrometer equipment where hazards may be present, you must protect yourself by wearing Personal Protective Equipment (PPE) and be trained to enter confined spaces. Examples of confined spaces are manholes, pumping stations, pipelines, pits, septic tanks, sewage digesters, vaults, degreasers, storage tanks, boilers, and furnaces.

You must follow all state and local laws, as well as Occupational Safety And Health Administration (OSHA) regulations concerning Personal Protective Equipment, confined-space entry, and exposure to bloodborne pathogens. Specific requirements can be found in the OSHA section of the Code of Federal Regulations: *29 CFR, 1910.132 - 1910.140, Personal Protective Equipment; CFR Title 29, Part 1910.146, Permit-Required Confined-Spaces; and 29 CFR, 1910.1030, Bloodborne Pathogens.*



WARNING!

Incorrect installation or removal of SPI Mag meters can result in serious injury or death. Read the instructions in this manual on the proper procedures carefully.



WARNING!

Never enter a confined space without testing the air at the top, middle, and bottom of the space. The air may be toxic, oxygen deficient, or explosive. Do not trust your senses to determine if the air is safe. You cannot see or smell many toxic gases.



WARNING!

Never enter a confined space without the proper safety equipment. You may need a respirator, gas detector, tripod, lifeline, and other safety equipment.



WARNING!

Never enter a confined space without standby/rescue personnel within earshot. Standby/rescue personnel must know what action to take in case of an emergency.



WARNING!

Pressurized pipes should only be hot tapped, cut, or drilled by qualified personnel. If possible, depressurize and drain the pipe before attempting any installation.



WARNING!

Carefully read all safety warning tags attached to the meter.

2.0 SPI MAG DESCRIPTION OF COMPONENTS

2.1 Overview

The SPI Mag Model 282L flowmeter combines an innovative sensor with a comprehensive electronics package to provide accurate flow measurement for full-pipe flow monitoring applications.

The insertable sensor (available for one-inch and two inch taps) uses electromagnetic technology to measure water velocity. The streamlined, debris-shedding sensor shape allows the SPI Mag to be used under many flow conditions.

SPI Mag has many features to suit a wide variety of applications, and is easily set up using the keypad and readouts. Refer to the converter manual shipped with your meter system.



NOTE

The converter and sensor are supplied as a matched system. (Figure 1 and Figure 2) Verify the system serial numbers on both the converter and sensor match. This will ensure a properly calibrated system. The System Serial Numbers begin with MM20##### and are located on the side of the converter and on a tag near the end of the sensor cable.



Figure 1. Procomm Go remote mount converter

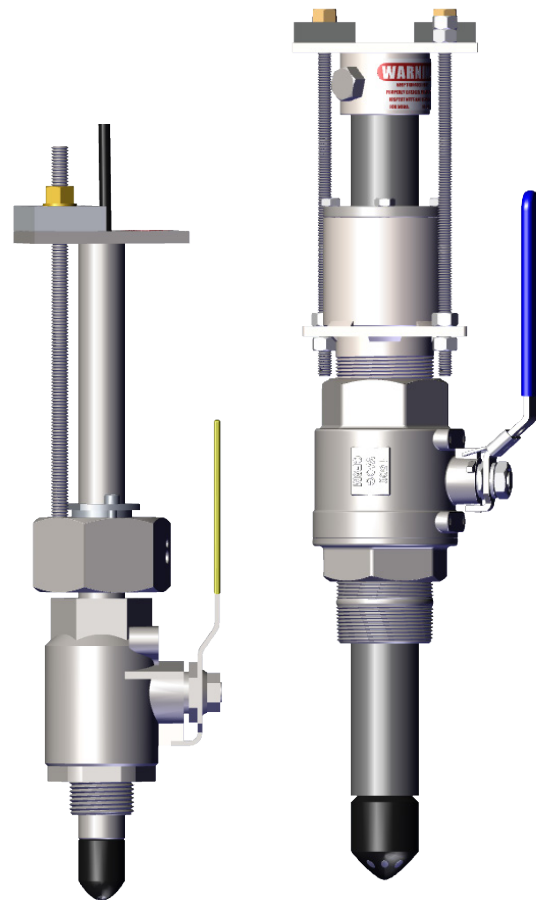

Figure 2. 1" and 2" Sensor with Insertion Hardware

The valves are optional or supplied by the customer, and are shown for illustration only.

2.2 Flow Calculation

The velocity measurements provided by the full-pipe sensor are used to calculate flow. Flow (also known as Q, as the flow rate, or as throughput) is the amount of fluid moving through a pipe in a period of time. For example, if 100 gallons of water move past the sensor in one minute, the flow is 100 gallons per minute (GPM).

To calculate the flow, two things are needed: The cross-sectional area of the pipe and the average velocity.

Cross-sectional area is found using the inside diameter of the pipe.

I **NOTE:** It is required that the exact inside diameter of the pipe is input into the flow computer for the SPI Mag to provide accurate flow data.

Average velocity is found using the sensed velocity (measured by the sensor). A site calibration is performed to determine the velocity profile. This allows the flowmeter to calculate the average velocity from the sensed velocity.

Flow is calculated by using the Continuity Equation:

Flow = Average Velocity x Area

2.3 Profiling Information

For information about the Profiling and Site Calibration, refer to these documents:

- One Inch Full Pipe Sensor Installation and Profiling Guide, Lit.# 24510-58.
- Two Inch Full Pipe Sensor Installation and Profiling Guide, Lit.# 24510-59.

2.4 Full Pipe Sensors

The full pipe sensor makes use of Faraday’s Law of Electromagnetic Induction to measure water velocity. Faraday’s Law states a conductor, moving through a magnetic field, produces a voltage.

Because water is a conductor, water moving through a magnetic field produces a voltage. The magnitude of the voltage is directly proportional to the velocity of the water. The sensor generates an electromagnetic field, creating a voltage in the water. The two velocity electrodes, along with the ground electrode measure this voltage. A faster water velocity produces a higher voltage. By accurately measuring this voltage, the velocity is determined. (Figure 3)

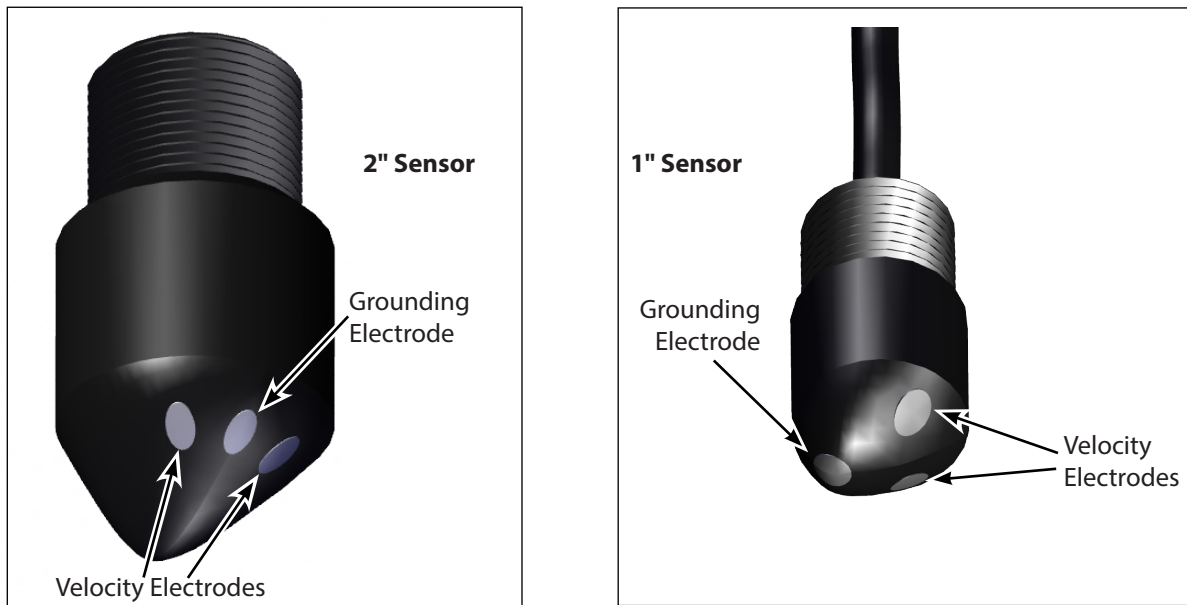

Figure 3. 2" and 1" 282L Sensors

3.0 PARTS DIAGRAMS

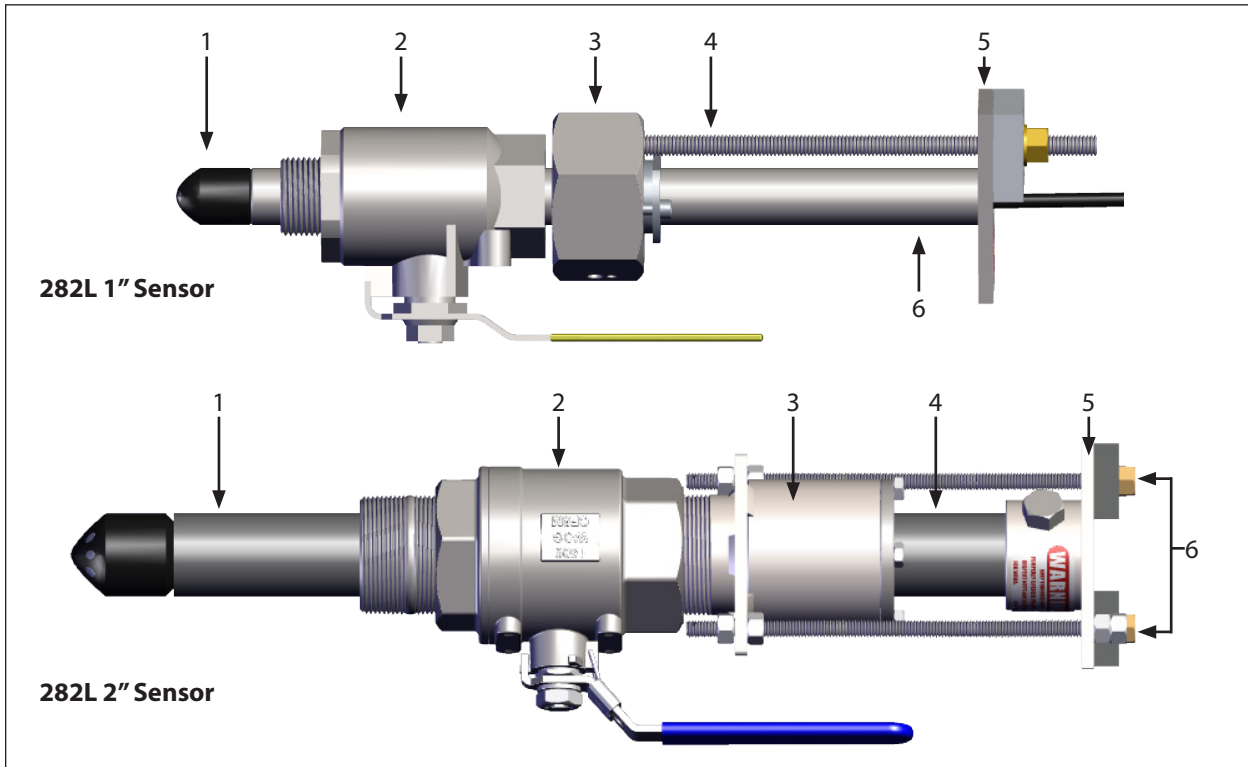

Figure 4. Parts Diagrams

Item Number	Part Name and Part Number
1	Sensor Assembly 1" 60080X001 Sensor Assembly 2" 600028X001
2	Ball Valve 1" Bronze 43801 Ball Valve 2" Bronze 43055
3	Compression Seal Assembly 1" 800003801 Compression Seal Assembly 2" 42205
4	1" Insertion Tube with Cap 12" 42292 24" 42292-1 36" 42292-2 2" Insertion Tube without Cap 18" 42198 24" 42198-1 30" 42198-2 Over 30" use SS tube 42204-xx
5	Insertion Tube Cap 1" Consult Factory Insertion Tube Cap 2" 55042
6	3/8" SS Long Threaded Rod 42199

NOTE: Valves are optional or supplied by user.

4.0 **SENSOR PROBE INSTALLATION**

Please read the following information before installing the SPI Mag Sensor

4.1 **Site Selection**

Install the sensor at an adequate distance from elbows, T-junctions, Y-junctions, active valves. Whenever possible, install the sensor upstream from a bend or junction.

4.2 **Sensor Clearance**

The sensor will protrude from the pipe when installed demanding sufficient clearance (distance H, in Figure 5 below) from any obstruction for the purposes of installation and removal.

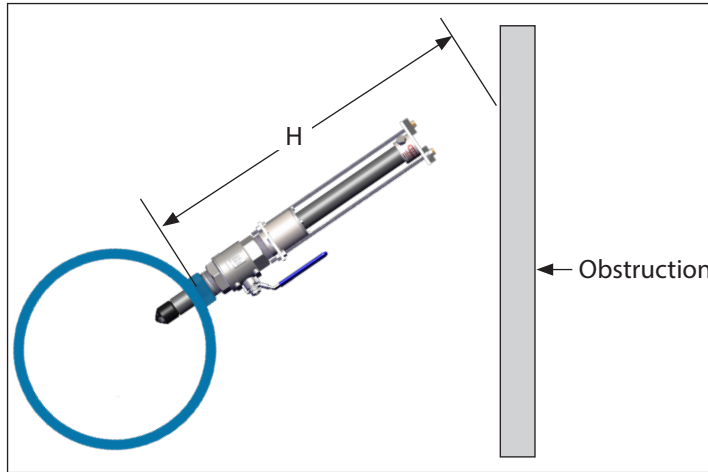

Figure 5. Sensor Clearance Distance

Distance H above is estimated by adding three measurements:

1. The height from the outer pipe wall to the top of the installation valve
2. The length of the meter (see the table below)
3. Additional 9" of working space

	Insertion Tube Length	Overall Sensor Length
1" 282L	12"	18.25"
	24"	30.25"
	36"	42.25"
2" 282L	18"	24.25"
	24"	30.25"
	30"	36.25"

4.3 Pipe Valve Installation



WARNING!

Pressurized pipes should only be hot tapped, cut, or drilled by qualified personnel using high quality saddles, valves and stainless steel nipples. If possible, depressurize the pipe before attempting any installation.

Install a 2" (50mm) full port valve or corporation stop with a 2" (50mm) NPT female pipe thread output for the 2" sensor, or a 1" (25mm) full port valve or corporation stop with a 1" (25mm) NPT female pipe thread output for the 1" sensor. Follow any and all installation instructions provided for the valve that you have chosen. The valve or corporation stop can be installed onto a welded coupling or pipe saddle. See Figure 6.



IMPORTANT: The MINIMUM port inside diameter for all installation valves is 1-7/8" (48mm).

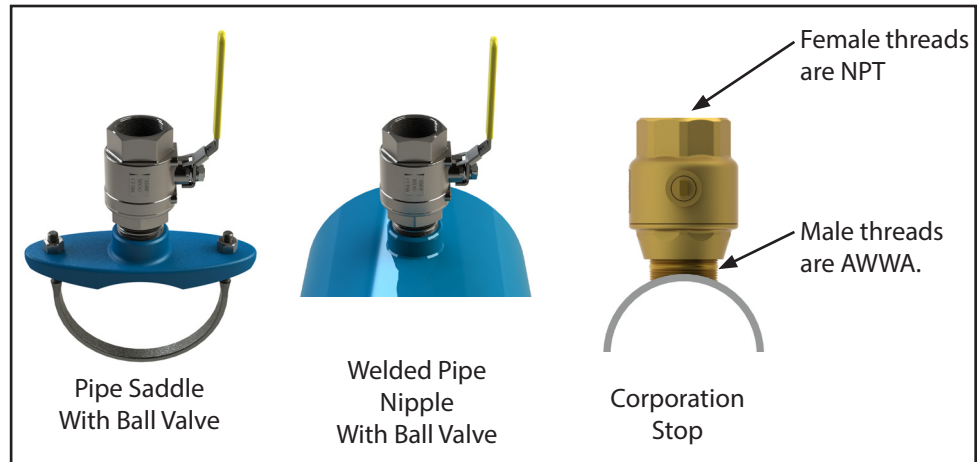

Figure 6. Installation Valve Options

4.4 Sensor Assembly Installation

The sensor assembly uses a compression seal, which keeps the sensor watertight when the pipe is under pressure. (Figure 7) Care must be taken when installing the sensor, to avoid leaks.

1. Visually inspect all elements of the installation to ensure they are structurally sound and of high quality materials, including all welds, couplings and nipples. To prevent future corrosion, nipples should be high quality stainless steel.
2. Put a generous amount of the pipe sealant (not supplied with the sensor) on the compression seal threads. (Teflon tape may also be used.) **NOTE:** if pipe sealant gets on the sensor electrodes the velocity signal may be lost.
3. Place the compression seal threads over the pipe valve. Turn the entire sensor assembly clockwise to secure the assembly to the valve.
4. The seal is secure when a large amount of force is required to turn the assembly. Line up the arrow (on the top plate) with the direction of the flow.

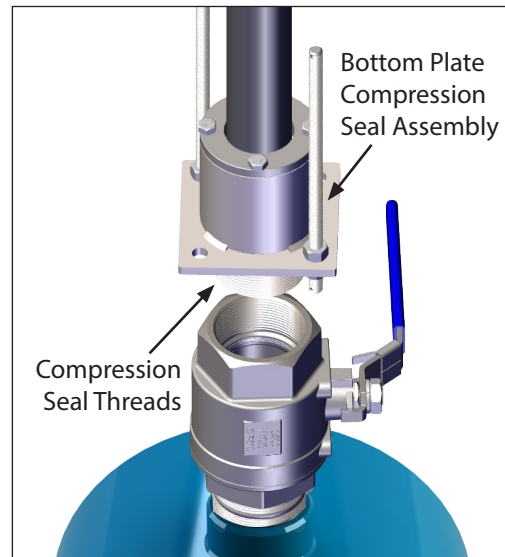

Figure 7. Sensor Installation

4.5 Inserting The Sensor



WARNING!

The compression seal/sensor assembly may be under pressure. Serious injury may result if proper procedures are not followed. Do not attempt to install the sensor without the restraining rods fully assembled.

Ensure the compression seal is only hand tightened.

1. Barely crack open the valve and tighten the compression seal as required to minimize leaks. A towel draped around the compression seal can reduce spray if necessary.
2. Open the valve completely. Failure to open the valve completely will cause the valve to scrape the sensor during insertions and may result in permanent damage to the sensor.
3. Insert the sensor into the pipe by simultaneously rotating clockwise the two captive nuts on the top plate for the 2" sensor, and the single captive nut on the 1" sensor. (Figure 8) For the two captive nuts on the 2" sensor use the two ratchet wrenches provided. It is recommended that the sensor insertion tool (p/n 75031) be used to rotate the captive nuts on the 2" sensor to ensure the top plate compresses evenly. See section 4.8 and Figure 12.



IMPORTANT

On the 2" installation hardware, if the captive nuts are not tightened simultaneously, the top plate will become crooked and cause the sensor to be inserted at an angle and may cause permanent damage to the sensor.

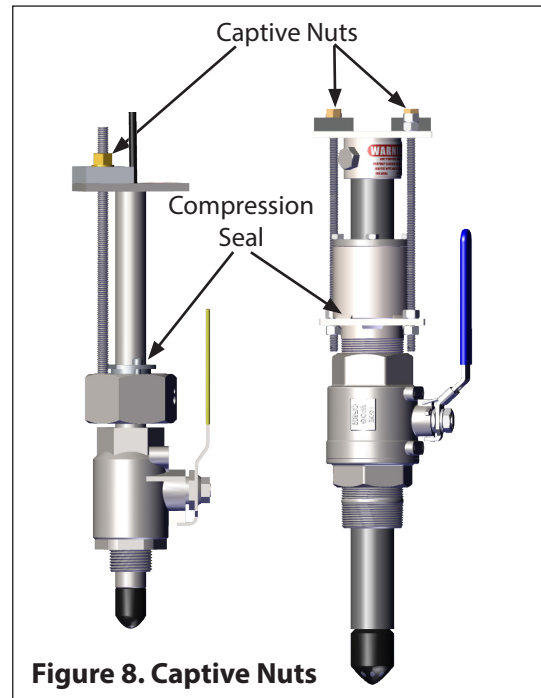

Figure 8. Captive Nuts

4.6 Clean Water Sensor Position

If the flow is clean water the sensor can be placed at 1/8 of the inside diameter. To position the sensor at 1/8 of the ID, follow the instructions below:

- Measure the tube from the top of the cap to the end of the sensor to find the tube length (TL).
- Calculate (1/8 ID): $1/8 \text{ ID} = 0.125 \times \text{Pipe ID}$
- Add wall thickness to 1/8 ID.
- Calculate distance A: $A = TL - (1/8 \text{ D} + \text{WT})$
- Set the top edge of the insertion tube cap distance A from the pipe.

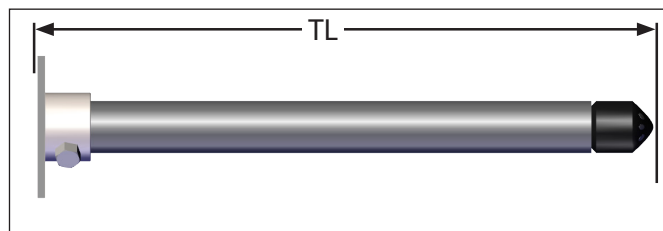

Figure 9. Tube Length (TL)

If the flow is clean water, the sensor can be left at the 1/8 D position. (Figure 10) Do not leave the sensor in this position for raw waste water because debris could collect on the sensor and affect the velocity readings. In waste water applications, position the sensor at location 0.00. See section 4.7.

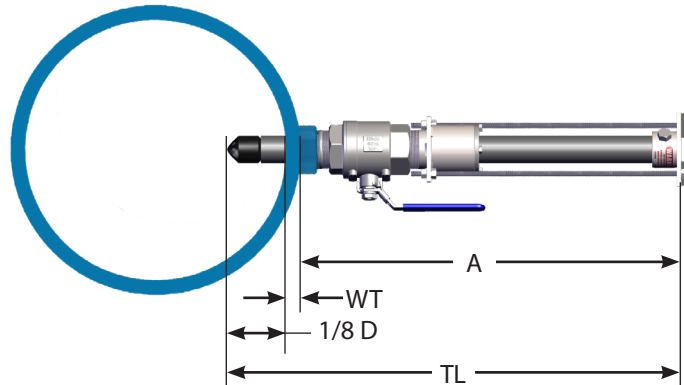

Figure 10. 1/8 ID Position

4.7 Raw Water Sensor Position

The operation position for raw waste water and sludge is at sensor location 0.00 to prevent debris from collecting on the sensor and affecting velocity readings. To position the sensor at this location follow the instructions below:

- Calculate distance A by subtracting the pipe wall thickness (WT) and 3/4" from length C. See Figure 11 for Length C (Tube Length).
- Position the top edge of the insertion tube cap distance A from the pipe.

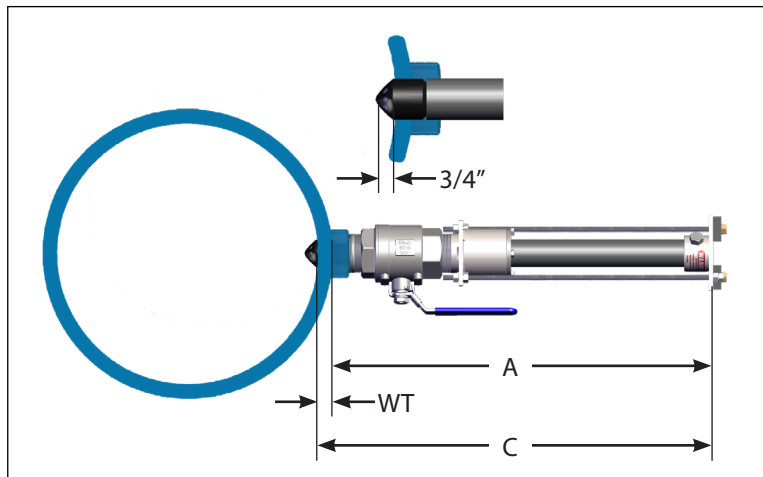

Figure 11. 0.00 Position

4.8 Sensor Insertion Tool

McCrometer recommends using a sensor insertion tool (Figure 12) (P/N 75031) to help with inserting the sensor and to avoid any damage to the sensor. Place the profiling insertion tool over the captive nuts and lock it into place with spring locks located on the bottom of the tool. Using the provided wrench rotate the high gear shaft clockwise until the bottom of the sensor reaches the far wall of the pipe.

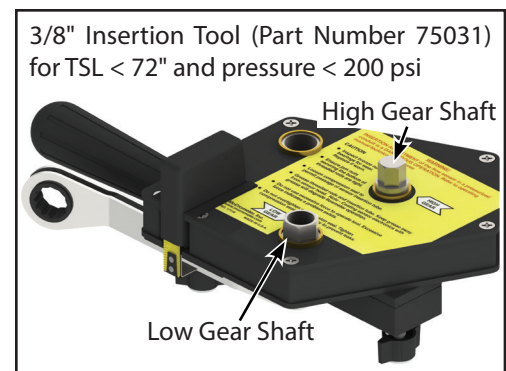

Figure 12. Sensor Insertion Tool

5.0 SENSOR REMOVAL



WARNING!

The pipe may be under pressure. Serious injury or death may result if proper procedures are not followed. To remove the sensor follow the steps below:

1. Visually inspect the pipe and entire assembly for damage or corrosion paying close attention to any nipples and welded couplings. If there is any doubt as to the condition of any element of the pipe or sensor, depressurize the line before attempting a removal of the sensor.
2. Loosen the compression seal until the seal just begins to leak. This will relieve the pressure on the compression seal allowing the sensor to be removed. Draping a towel around the compression seal can reduce any spraying water. **NOTE:** The compression seal may prevent immediate leakage on sensors installed for a long period of time until the sensor begins to rise.
3. On the 1" sensor, rotate the captive nut on the top plate to raise the sensor.. On the 2" sensor rotate the captive nuts on the top plate simultaneously. The sensor insertion tool is recommended. See Section 4.8. This will cause the sensor to rise out of the pipe. If the line is under pressure do not remove the sensor from the compression seal completely. Only raise the sensor until it is clear of the valve, but still below the compression seal. Once the sensor has cleared the valve mechanism, the valve can then be closed. Do not attempt to force the valve closed while the sensor is still passing through the valve as permanent damage to the sensor can occur.
4. Once the valve is closed, the entire sensor can be removed from the valve.

6.0 MAINTENANCE

The SPI Mag is essentially a maintenance free meter with no user serviceable parts. However, the metered fluid may contain of solids or other contaminants coat the sensor electrodes. A periodic inspection may be recommended to ensure the sensor electrodes are clean. To clean the unit remove the sensor following all of the instructions and safety warning contained in Section 5.0. When the sensor is removed from the pipe, carefully wipe down the sensor with a soft cloth and a mildly abrasive detergent, such as a liquid kitchen detergent.

7.0 SPECIFICATIONS

Measurement	
	<ul style="list-style-type: none"> Volumetric flow in filled flow conduits 2" (50mm) to 96" (2,440 mm) diameter utilizing insertable velocity sensor. 1" meter = 2" to 30" pipe I.D.; 2" meter = 6" to 96" pipe I.D. Flow indication in English Standard or Metric units
Flow Measurement	
Method	Electromagnetic
Accuracy	+/- 2% of measured value ±0.03 ft/s (±0.009 m/s)
Velocity range	+0.3 to +32 ft/s (+0.09 to +10 m/s)
Direction measurement	Has reverse flow indication
Materials	
Sensor	Polyurethane exposed to flow
2" sensor mounting	PVC and Stainless Steel exposed to flow. (Stainless Steel Insertion Tube Optional)
Compression seal	Buna "N" O-Ring seal exposed to flow
Environmental Ranges	
Pressure/temperature limits	<ul style="list-style-type: none"> PVC Insertion Tube: Up to 105°F (41°C) at 150 PSI Stainless Steel Insertion Tube: Up to 160°F (71°C) at 250 PSI (McCrometer recommends the use of Stainless Steel) <p>Note regarding storage: During freezing conditions and when meter is not in use, sensor must be removed from pipe and stored in dry conditions.</p> <p>NOTE: Damage to the sensor caused by allowing the sensor freeze in the pipe is not covered by the warranty.</p>
Electrical Connections	
	Compression gland seals for 0.125" to 0.375" dia. round cable
Sensor Cable Lengths	
Standard	25' McCrometer supplied submersible cable with each remote mount unit.
Optional	Up to 200 feet, or 25 feet max for battery powered.
IP Rating	
	IP68 submersible sensor
Insertion Tube	
<p>To determine insertion tube length for typical near wall installations, divide the pipe I.D. by 8 and add 18".</p> <p>For full profiles, add 18" to the pipe I.D.</p> <p>Tube assemblies include rods and mounting hardware</p>	
1" tube	<ul style="list-style-type: none"> Stainless steel tube, 12" length. Will profile 4" pipe I.D. Stainless steel tube, 24" length. Will profile 16" pipe I.D. Stainless steel tube, 36" length. Will profile 28" pipe I.D.
2" tube	<ul style="list-style-type: none"> PVC tube, 18" length. Will profile a 10" pipe I.D. PVC tube, 24" length. Will profile a 16" pipe I.D. PVC tube, 30" length. Will profile a 22" pipe I.D. Opt.: stainless steel tube. Specify length - 240" maximum

Flow Meter Specifications (cont.)

System Options

- Stainless Steel ID Tag
- Sensor Insertion Tool
- Additional Sensor Cable up to 200' (for longer lengths consult factory)
- Valves

Ordering Requirements

At the time of ordering, please be prepared to provide the following information:

- Model and tap size
- Insertion tube length
- Pressure
- Minimum flow
- Maximum flow
- Typical flow
- Fluid
- Pipe I.D.
- Cable length
- Temperature
- Any other chemicals in use
- Indicator and totalizer units

PROCOMM GO CONVERTER SPECIFICATIONS

Physical Specifications																																																	
Electronic Housing	Diecast aluminum, powder coated enclosure w/ tamper resistant seal, 6½" x 6½" x 43/8" tall																																																
Transmitter Dimensions	See "Dimensions" section for meter mount and remote mount transmitter dimensions.																																																
Power	<p>Battery: Standard: three 3.6V lithium-thionyl chloride (Li-SOCI2) D size batteries with two AA backup batteries</p> <p>AC Power: 100-240VAC/45-66Hz (4W)</p> <p>DC Power: Linear power supply 10-35VDC (4 W)</p>																																																
Electrical Connections	<ul style="list-style-type: none"> • Optional shielded cable for 10-32VDC/4-20 mA output • Optional shielded cable for pulse out 																																																
Performance and Operational Specifications																																																	
Battery Life	Five-year expected battery life, five-year battery warranty																																																
Location	Indoor or outdoor use																																																
Altitude	Operating: 2000 meters Storage: 12,000 meters																																																
Operating Temperature	-4° to 140° F (-20° to 60° C)																																																
Storage Temperature	-4° to 140° F (-20° to 60° C)																																																
Relative Humidity	0% to 100%																																																
IP Rating	IP67 Die cast aluminum transmitter																																																
Outputs	<p>Digital output: Digital pulse (open collector) output for volumetric - Two isolated digital pulse (open collector) outputs for volumetric - AMI output</p> <p>Analog output: 4-20mA: Galvanically Isolated, 16 Bit resolution. All power configurations (including battery).</p> <p>Note: 9-30 VDC loop power required (not supplied via transmitter)</p>																																																
Display and Measurement																																																	
Display	<ul style="list-style-type: none"> • 2-Line LCD display (no backlight) • Non-volatile memory • Anti-reverse totalizer (standard) • Total (to 9 digits of precision) • Flow rate and velocity (to 5 digits of precision) • Two alarms: low battery and empty pipe (optional) • Opening lid activates display 																																																
Digits	5 Rate, 9 Total																																																
Units	<table border="0"> <tr> <td>GPM</td><td>Gallons per minute</td> <td>IGM</td><td>Imperial gal per minute</td> <td>CFM</td><td>Cubic feet per minute</td> </tr> <tr> <td>MGD</td><td>Mega gal per day</td> <td>MI9</td><td>Miners inch (9G)</td> <td>B5M</td><td>Barrels per minute (55G)</td> </tr> <tr> <td>CFS</td><td>Cubic feet per second</td> <td>MI1</td><td>Miners inch (11.22G)</td> <td>B5H</td><td>Barrels per hour (55G)</td> </tr> <tr> <td>MLD</td><td>Megaliters per day</td> <td>APD</td><td>Acre feet per day</td> <td>B5D</td><td>Barrels per day (55G)</td> </tr> <tr> <td>LPS</td><td>Liters per second</td> <td>KLH</td><td>Kiloliters per hour</td> <td>B4M</td><td>Barrels per minute (42G)</td> </tr> <tr> <td>CMH</td><td>Cubic meters per hour</td> <td>LPH</td><td>Liters per hour</td> <td>B4H</td><td>Barrels per hour (42G)</td> </tr> <tr> <td>LPM</td><td>Liters per minute</td> <td>CMM</td><td>Cubic meters per minute</td> <td>B4D</td><td>Barrels per day (42G)</td> </tr> <tr> <td>GPH</td><td>Gallons per hour</td> <td>CFM</td><td>Cubic feet per minute</td> <td></td><td></td> </tr> </table>	GPM	Gallons per minute	IGM	Imperial gal per minute	CFM	Cubic feet per minute	MGD	Mega gal per day	MI9	Miners inch (9G)	B5M	Barrels per minute (55G)	CFS	Cubic feet per second	MI1	Miners inch (11.22G)	B5H	Barrels per hour (55G)	MLD	Megaliters per day	APD	Acre feet per day	B5D	Barrels per day (55G)	LPS	Liters per second	KLH	Kiloliters per hour	B4M	Barrels per minute (42G)	CMH	Cubic meters per hour	LPH	Liters per hour	B4H	Barrels per hour (42G)	LPM	Liters per minute	CMM	Cubic meters per minute	B4D	Barrels per day (42G)	GPH	Gallons per hour	CFM	Cubic feet per minute		
GPM	Gallons per minute	IGM	Imperial gal per minute	CFM	Cubic feet per minute																																												
MGD	Mega gal per day	MI9	Miners inch (9G)	B5M	Barrels per minute (55G)																																												
CFS	Cubic feet per second	MI1	Miners inch (11.22G)	B5H	Barrels per hour (55G)																																												
MLD	Megaliters per day	APD	Acre feet per day	B5D	Barrels per day (55G)																																												
LPS	Liters per second	KLH	Kiloliters per hour	B4M	Barrels per minute (42G)																																												
CMH	Cubic meters per hour	LPH	Liters per hour	B4H	Barrels per hour (42G)																																												
LPM	Liters per minute	CMM	Cubic meters per minute	B4D	Barrels per day (42G)																																												
GPH	Gallons per hour	CFM	Cubic feet per minute																																														

PROCOMM GO CONVERTER SPECIFICATIONS (CONT.)



Display and Measurement (cont.)

Totalizer Units	GAL	Gallons	B42	Barrel (42G)	MH1	Miners Inch Hour (11.22G)
	CUF	Cubic Feet	B46	Barrel (46G)	MD1	Miners Inch Day (11.22G)
	AFT	Acre Feet	B55	Barrel (55G)	MH9	Miners Inch Hour (9G)
	CUM	Cubic Meters	IMG	Imperial Gallon	MD9	Miners Inch Day (9G)
	LIT	Liters	AIN	Acre Inch	KGL	Kilo Gallons
	MML	Megaliter	TON	Ton (Short)	MGL	Mega Gallons
	MTT	Metric Ton (KL)	MM1	Miners Inch Minute (11.22G)	IN3	Cubic Inch
	B31	Barrel (31G)	MM9	Miners Inch Minute (9G)		
	Data Logger	Standard with all models, minimum of five years of data stored				

Other Specifications

Options and Accessories	<ul style="list-style-type: none"> Data Logger - included as standard with five years of data storage at default (12hr) interval. (Cable sold separately) AC, DC, and battery powered with battery backup powered available
Safety	<ul style="list-style-type: none"> IEC 61010-1, Pollution Degree II Overvoltage protection Category III

Certifications

Standard Model	<ul style="list-style-type: none"> ISO 9001:2015 certified quality management system CE Certified by MET to UL 61010-1 	  
HL Model	<ul style="list-style-type: none"> ISO 9001:2015 certified quality management system CE Certified by MET to UL 61010-1 and MET C22.2 No. 61010-1-04 <ul style="list-style-type: none"> Class I, Division 2, Groups A B C D, T5 Class I, Zone 2, IIC T5 <p><i>Note: ProComm GO with SmartTrax On Board is not available for hazardous locations.</i></p>	

8.0 SPI MAG ORDERING INFORMATION

The standard SPI Mag includes:

- SPI Mag sensor
- ProComm transmitter
- 25-foot sensor cable
- Installation and operation manual

Options

- Extended sensor cable (up to 200', for longer lengths, consult factory)
- Sensor insertion tool - Part No. 75031
- Additional Installation and Operation manuals - Part No. 24511-13
- RS485 Port

Returning a unit for repair

If the unit needs to be returned to the factory for repair, please do the following:

- Prior to calling for a return authorization number, determine the model number, serial number (located inside the front panel of converter), and reason for return.
- Contact McCrometer Customer Service Department and ask for a Return Authorization (RA) number.
 - Telephone: 1-800-220-2279
 - Email: customerservice@mccrometer.com
- Ship the meter in the original packaging, if possible. Do not ship manuals, power cords, or other parts with your unit unless required for repair.
- Please make sure the meter is clean and free from foreign debris prior to shipping.
- Write the RA number on the outside of the shipping box. All return shipments should be insured.
- Address all shipments to:

McCrometer, Inc.
RA#
3255 W. Stetson Ave
Hemet, CA 92545

9.0 CONVERSION TABLES

Table of Decimal Equivalents

Fraction	Decimal
1/8	.125
1/4	.25
3/8	.375
1/2	.5
5/8	.625
3/4	.75
7/8	.875

Table of Conversions

Multiply	By	To Get
Centimeters	0.3937	Inches
Centimeters	0.03281	Feet
Inches	25.4	Millimeters
Feet	30.48	Centimeters
Square Feet	144.0	Square Inches
Square Inches	0.006944	Square Feet
Cubic Inches	0.0005787	Cubic Feet
Cubic Feet	7.481	Gallons
Cubic Feet	1728.0	Cubic Inches
Cubic Feet	0.02832	Cubic Meters
Cubic Feet	28.32	Liters
Cubic Meters	35.31	Cubic Feet
Cubic Meters	264.2	Gallons
US Gallons	3.785	Liters
US Gallons	0.1337	Cubic Feet
US Gallons	0.003785	Cubic Meters
US Gallons	.8326748	Imperial Gallons
Liters	0.2642	Gallons
$^{\circ}\text{F} = (^{\circ}\text{C} \times 9/5) + 32$	$^{\circ}\text{C} = (^{\circ}\text{F} - 32) \times 5/9$	

WARRANTY STATEMENT

McCrometer warrants that this product will be free from defects in material and workmanship for a period 24 months from the date the equipment was first installed, but in no event longer than 30 months from the date the equipment was first shipped by McCrometer. Repairs shall be warranted for 12 months or, if the repair is performed under this warranty, for the remainder of the original warranty period, whichever is less.

Buyer shall report any claimed defect in writing to McCrometer immediately upon discovery and in any event, within the warranty period. McCrometer shall, at its sole option, repair the equipment or furnish replacement equipment or parts thereof, at the original delivery point.

McCrometer shall not be liable for costs of removal, reinstallation, or gaining access. If Buyer or others repair, replace, or adjust equipment or parts without McCrometer prior written approval, McCrometer is relieved of any further obligation to Buyer under this Article with respect to such equipment.

No equipment furnished by McCrometer shall be deemed to be defective by reason of normal wear and tear, failure to resist erosive or corrosive action of any fluid or gas (unless otherwise specified in Quotations/ Purchase Order Specifications), Buyer's direct or indirect failure (or the failure of its agents or contractors) to properly store, install, operate, or maintain the equipment in accordance with good industry practices or specific recommendations of McCrometer, or Buyer's failure to provide complete and accurate information to McCrometer concerning the operational application of the equipment.

THE FOREGOING LIMITED WARRANTIES WITH RESPECT TO EQUIPMENT AND PRODUCTS ARE EXCLUSIVE AND IN LIEU OF ANY AND ALL OTHER WARRANTIES OF QUALITY OR PERFORMANCE, EXPRESS, IMPLIED OR STATUTORY, INCLUDING, WITHOUT LIMITATION, ANY AND ALL WARRANTIES OF MERCHANTABILITY OR FITNESS OF SAID EQUIPMENT AND PRODUCTS FOR ANY PARTICULAR PURPOSE.

MCCROMETER DISCLAIMS ANY WARRANTY, WHETHER EXPRESS OR IMPLIED, REGARDING THE SUITABILITY OF PRODUCTS AND EQUIPMENT SUPPLIED PURSUANT TO ANY PURCHASE ORDER FOR INSTALLATION IN ANY PARTICULAR SYSTEM OF SYSTEMS. MCCROMETER MAKES NO WARRANTY OF ANY KIND WITH RESPECT TO ANY SERVICES PERFORMED BY MCCROMETER OR ITS AGENTS PURSUANT TO ANY QUOTATION.

Purchaser's sole remedy and manufacturer's sole obligation for alleged product failure, whether under warranty claim or otherwise, shall be the aforesaid obligation of manufacturer to repair or replace products returned within twenty-four months after date of original shipment. The manufacturer shall not be liable for, and the purchaser assumes and agrees to indemnify and save harmless the manufacturer in respect to, any loss or damage that may arise through the use by the purchaser of any of the manufacturer's products.

McCrometer does not authorize any person or entity (including, without limitation, McCrometer agents and employees) to make any representations (verbal or written) contrary to the terms of this limited warranty or its exclusions. Such terms of this limited warranty and its exclusions can only be effectively modified in writing and only by the President of McCrometer.

Copyright © 2024 McCrometer, Inc. All printed material should not be changed or altered without permission of McCrometer. Any published pricing, technical data, and instructions are subject to change without notice. Contact your McCrometer representative for current pricing, technical data, and instructions.

3255 WEST STETSON AVENUE • HEMET, CALIFORNIA 92545 USA
TEL: 951-652-6811 • 800-220-2279 • FAX: 951-652-3078
www.mccrometer.com

