

SPI Mag 3000 Battery Powered Electromagnetic Flow Meter

Quick Start Installation Guide

30126-51 Rev. 1.0
12SEP2024



About This Quick Start Guide

This quick start guide is designed to provide installation instructions when the location of the sensor installation has been predetermined. If not, see the SPI Mag 3000 Installation, Operation and Maintenance Manual (Lit. No. 30126-41).

About This Quick Start Guide 1

- 1. Verify Contents of Shipping Box 2**
- 2. Verify Flow Meter Serial Numbers 2**
- 3. Flow Calculation 2**
- 4. Full Pipe Sensors 3**
- 5. Parts Diagram 3**
- 6. Sensor Installation Location 3**
- 7. Determine Sensor Clearance 3**
- 8. Install Pipe Valve 4**
- 9. Sensor Installation Tool 4**
- 10. Sensor Assembly Installation 4**
- 11. Inserting the Sensor 5**
- 12. Clean Water Sensor Position 6**
- 13. Raw Water Sensor Position 6**
- 14. Connect Sensor Outputs to Converter . 7**

WARNING!

 Incorrect installation or removal of FPI Mag meters can result in serious injury or death. Read the instructions and the safety warnings in the supplied manual carefully before installation. This guide is not intended as a substitute for reading the manual.

1. Verify Contents of Shipping Box

Upon receiving the meter, unpack the contents of the shipping box and verify that the items in listed below are included.

NOTE: If any of the above-listed items are not present, contact the factory before continuing with installation.

Contents of Shipping Box

Item	Quantity
SPI Mag Sensor	1
Long threaded retaining rods	2
ProComm Go Converter	1
SPI Mag Installation, Operation and Maintenance Manual	1
ProComm Go Converter Installation, Operation and Maintenance Manual	1
3/4" reversible ratchet wrench	1
Compression Seal Assembly	1
Hex nuts (3/8")	4
Locking cotter pins	2
Power cord (8', 115 VAC)	1
Calibration Certificate	1

Tools Provided:

Two - 9/16" or 3/4" reversible ratchet wrenches. (Size is dependent on the size of the retaining rods supplied with the sensor and determined at the time of order.)

Tools recommended for installation

- One - Pipe wrench capable of a 4" span
- One - 7/16" wrench or crescent wrench
- One - Sensor Insertion Tool (3/8" or 1/2")

NOTE: It is recommended that the Sensor Insertion Tool be used for easier and faster installation. See STEP 12.

2. Verify Flow Meter Serial Numbers

Verify the system serial numbers on both the sensor and converter match to ensure a properly calibrated system.

The meter serial number is located on the side of the sensor body on a silver label. Both 1" and 2" models are shown below.

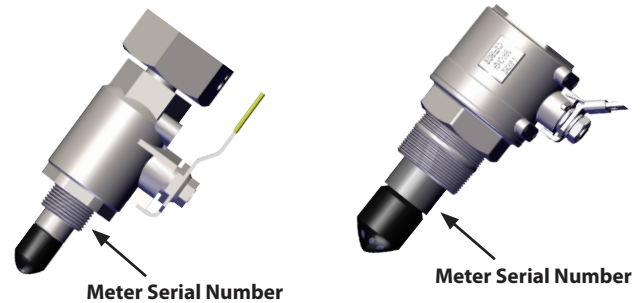

The tag on the side of the converter has the converter model number, the converter serial number and the meter serial number.

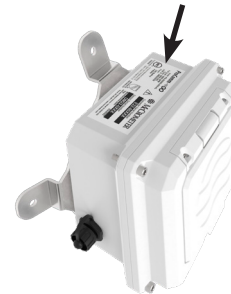

3. Flow Calculation

To calculate the flow, two things are needed: The cross-sectional area of the pipe and the average velocity.

Cross-sectional area is found using the inside diameter of the pipe. **Average velocity** is found using the sensed velocity (measured by the sensor). A site calibration is performed to determine the velocity profile. This allows the flow meter to calculate the average velocity from the sensed velocity.

Flow is calculated by using the Continuity Equation: **Flow = Average Velocity x Area**

If the engineering design for this installation requires that flow in the line be profiled, please refer to the SPI Mag Profiling Guides.

SPI Mag 1" Profiling Guide: Lit# 24510-58
 SPI Mag 2" Profiling Guide: Lit# 24510-59

The Profiling Guides can be downloaded at:
www.mccrometer.com/Library

4. Full Pipe Sensors

The full pipe sensor makes use of Faraday's Law of Electromagnetic Induction to measure water velocity. Faraday's Law states: **A conductor, moving through a magnetic field, produces a voltage.**

Because water is a conductor, water moving through a magnetic field produces a voltage. The magnitude of the voltage is directly proportional to the velocity of the water. The sensor generates an electromagnetic field, creating a voltage in the water. The two velocity electrodes, along with the ground electrode measure this voltage. A faster water velocity produces a higher voltage. By accurately measuring this voltage, the velocity is determined.

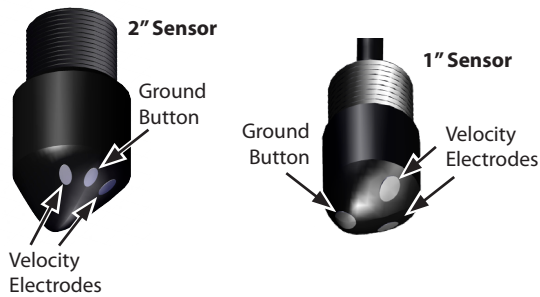

5. Parts Diagram

1	Sensor Assembly
2	Bronze Ball Valve
3	Compression Seal Assembly
4	1" Insertion Tube with cap 2" Insertion Tube without cap
5	Insertion Tube Cap
6	3/8" SS Long Threaded Rod

NOTE: Valves are optional or supplied by user.

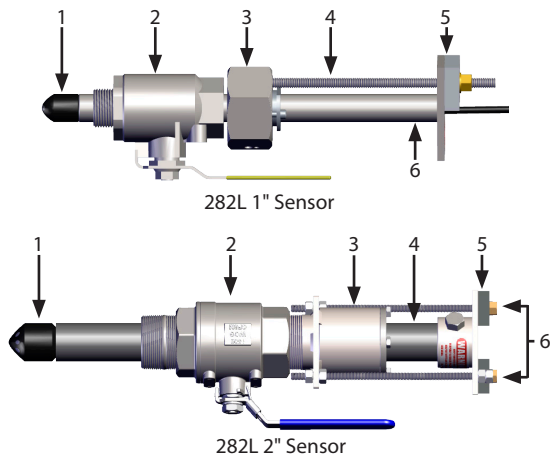

6. Sensor Installation Location

This Quick Start Guide is designed to provide installation instructions when the location of the sensor installation has been predetermined. If not, see the FPI Mag Installation, Operation and Maintenance manual (Lit. No. 30120-48).

7. Determine Sensor Clearance

The sensor will protrude from the pipe when installed requiring sufficient clearance from any obstruction.

The sensor will protrude from the pipe during installation and when installed requiring sufficient clearance from any obstruction.

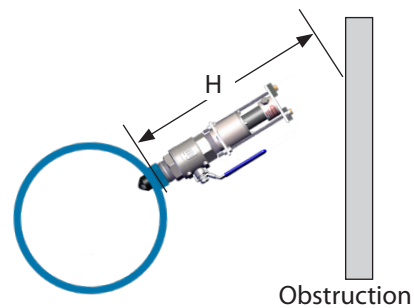

Distance H is estimated by adding three measurements:

1. the height from the outer pipe wall to the top of the installation valve
2. the length of the meter (see table)
3. additional 9" of working space

1" W3000		2" W3000	
Insertion Tube Length	Overall Sensor Length	Insertion Tube Length	Overall Sensor Length
12"	18.25"	18"	24.25"
24"	30.25"	24"	30.25"
36"	42.25"	30"	36.25"

8. Install Pipe Valve



WARNING! Pressurized pipes should only be hot tapped, cut, or drilled by qualified personnel using high quality saddles, valves and stainless steel nipples. If possible, depressurize the pipe before attempting any installation.

The sensor comes standard with a 2" stainless steel ball valve and a 2" x close stainless steel nipple. The 2" x close stainless steel nipple is to be used if the installation site has a female fitting, i.e., a welded coupling. If the installation site has a male fitting, i.e. a 2" nipple, then the supplied 2" x close stainless steel nipple is not required for the sensor installation.

Use pipe sealant or Teflon thread tape (not supplied with the sensor) when installing the valve onto the pipe.



Pipe saddle with ball valve



Welded pipe nipple with ball valve



Corporation stop



IMPORTANT: The MINIMUM port inside diameter for all installation valves is 1-7/8" (48mm).

9. Sensor Installation Tool

McCrometer recommends using a sensor insertion tool (P/N 75031) to help with inserting the sensor and to avoid any damage to the sensor.

Place the profiling insertion tool over the captive nuts and lock it into place with spring locks located on the bottom of the tool. Using the provided wrench rotate the high gear shaft clockwise until the bottom of the sensor reaches the far wall of the pipe.

3/8" Insertion Tool (Part Number 75031)
for TSL < 72" and pressure < 200 psi

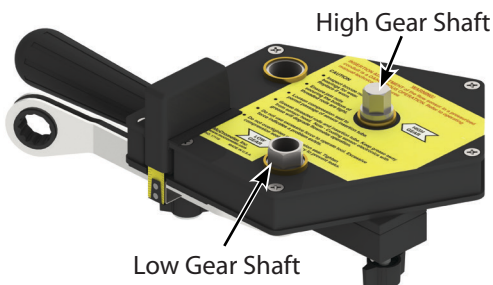

10. Sensor Assembly Installation

The sensor assembly uses a compression seal, which keeps the sensor watertight when the pipe is under pressure. Care must be taken when installing the sensor, to avoid leaks.

Visually inspect all elements of the installation to ensure they are structurally sound and of high quality materials, including all welds, couplings and nipples.

Put a generous amount of pipe sealant (not supplied with the sensor) on the compression seal threads. Teflon tape may also be used. NOTE: If pipe sealant gets on the sensor electrodes the velocity signal may be lost.

Place the compression seal threads over the pipe valve. Turn the entire sensor assembly clockwise to secure the assembly to the valve.

The seal is secure when a large amount of force is required to turn the assembly. Line up the arrow (on the top plate) with the direction of the flow.

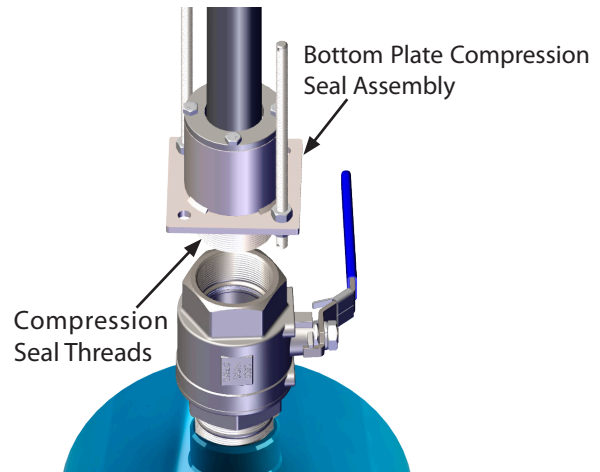

11. Inserting the Sensor

Follow the steps below to insert the sensor probe into the pipe.

1. If you disassembled and reassembled the compression seal, hand tighten the compression seal bolts and nuts. DO NOT FULLY TIGHTEN THE COMPRESSION SEAL BOLTS AND NUTS. If you did not disassemble the compression seal, proceed to step 2.
2. If the sensor is being installed under flowing conditions follow this step. If it is not, proceed to step 3.
Slightly open the valve to allow a little water into the compression seal assembly. Some water will leak from the compression seal. Lightly tighten the compression seal bolts and nuts as required to minimize the amount of water exiting the compression seal. A towel draped around the compression seal can reduce spray if necessary.
3. **Open the valve completely.** Failure to open the valve completely will cause the valve to scrape the sensor during insertions and may result in permanent damage to the sensor.

If you are using the sensor insertion tool:

4. Place the sensor insertion tool over the retaining rods and slide the retaining rods through the holes in the tool until it sits over the captive nuts.
5. Lock it into place with spring locks located on the bottom of the tool.
6. Using the provided wrench rotate the high gear shaft clockwise.
7. Continue to insert the sensor until the sensor probe tip reaches the far wall of the pipe and the load spring starts to compress.
8. Use the low gear shaft to apply pressure to the sensor when the sensor touches the other side of the pipe. Compression of the load spring is indicated by the movement of the set screw on the top plate.



If you are NOT using the sensor insertion tool:



IMPORTANT

If the captive nuts are not tightened simultaneously, the top plate will become crooked and cause the sensor to be inserted at an angle and may cause permanent damage to the sensor.

4. Rotate the two captive nuts on the top plate clockwise simultaneously with the provided 9/16" ratchet wrenches. This will insert the sensor probe into the pipe.
5. Continue inserting the sensor until the sensor probe tip reaches the far wall of the pipe and the load spring starts to compress. Compression of the load spring is indicated by the movement of the set screw on the top plate.

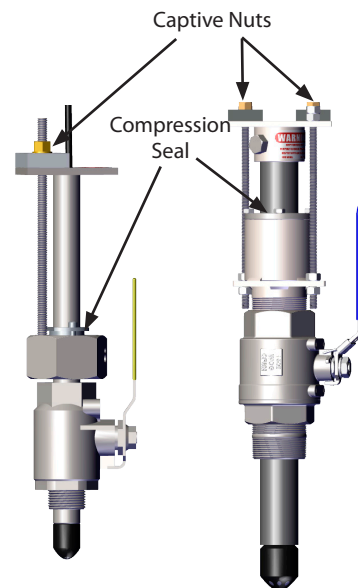

12. Clean Water Sensor Position

If the flow is clean water, the sensor can be placed at 1/8 of the inside diameter. To position the sensor at 1/8 of the ID, follow the instructions below:

Measure the tube from the top of the cap to the end of the sensor to find tube length (TL).

Calculate (1/8 D): $1/8 D = 0.125 \times \text{Pipe ID}$

Add wall thickness(WT) to 1/8 D.

Calculate distance A: $A = TL - (1/8 D + WT)$

Using the captive nuts, position the top edge of the tube cap so that its distance from the OD of the pipe is equal to "distance A" calculated above. See diagram.

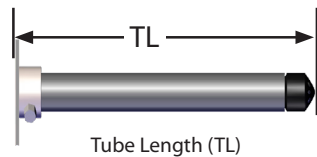

If the flow is clean water, the sensor can be left at the 1/8D position. Do not leave the sensor in this position for raw waste water because debris could collect on the sensor and affect the velocity readings. In waste water applications, position the sensor at location 0.00.

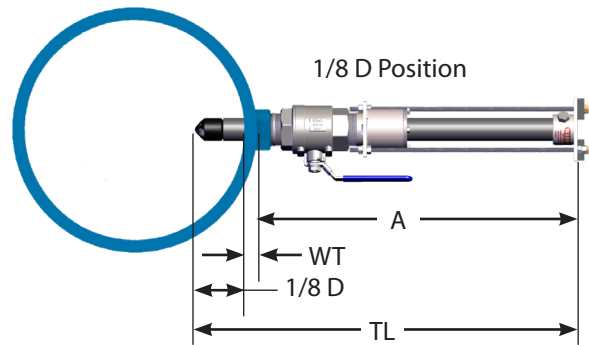

13. Raw Water Sensor Position

The operation position for raw waste water and sludge is at sensor location 0.00 to prevent debris from collecting on the sensor and affecting velocity readings. To position the sensor at this location follow the instructions below:

Calculate distance A by subtracting the pipe wall thickness (WT) and 3/4" from length C (Tube Length).

$$A = C - WT - 3/4"$$

Using the captive nuts, position the top edge of the tube cap so that its distance from the OD of the pipe is equal to "distance A" calculated above. See diagram.

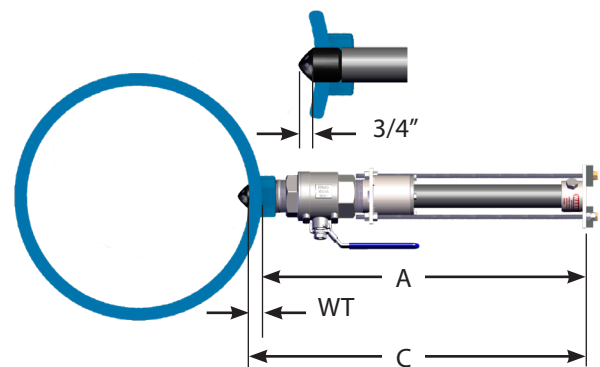

14. Connect Sensor Outputs to Converter

All electrical cables enter the converter through compression fittings located on the side of the converter. Ensure that all compression glands are properly tightened and all unused fittings are plugged so the case remains sealed.

All connections are made on the terminal board. To access the terminal board, loosen the four screws on the front of the converter and lift the converter open.

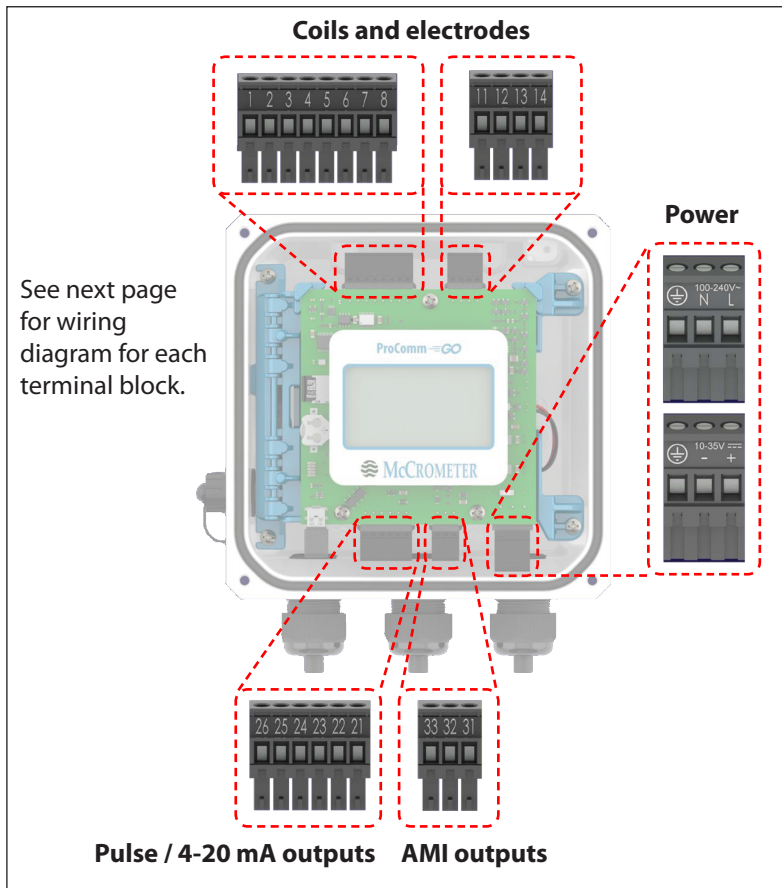

Terminal blocks

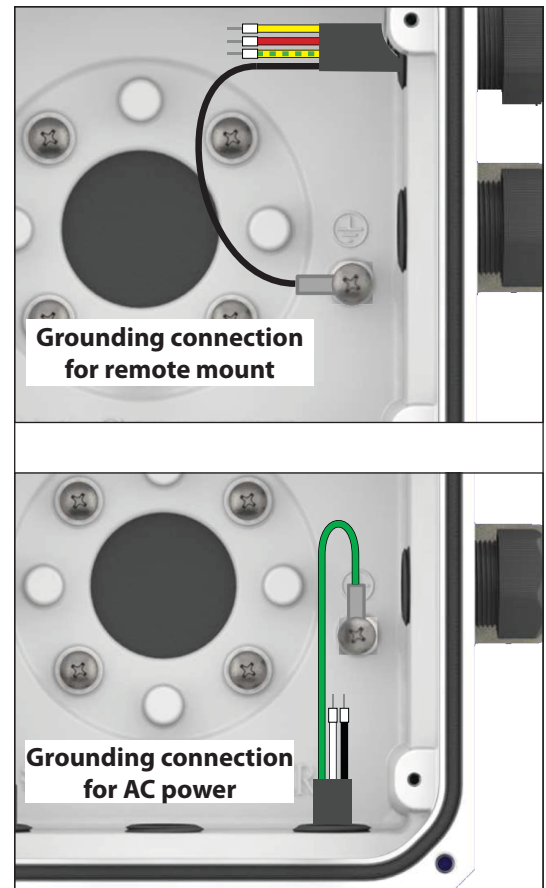

Grounding lug

TERMINAL BLOCK ASSIGNMENTS

ATTACHES TO CHASSIS LUG  BLACK

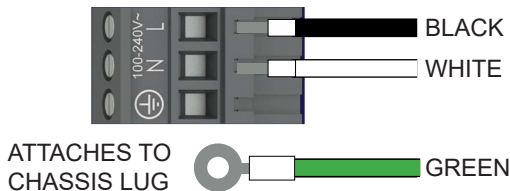
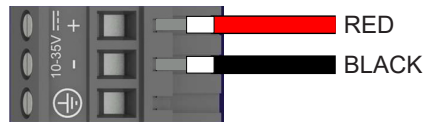
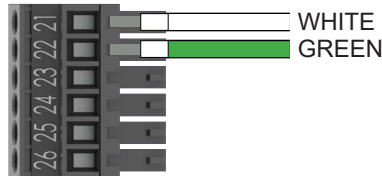
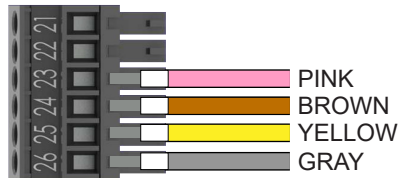
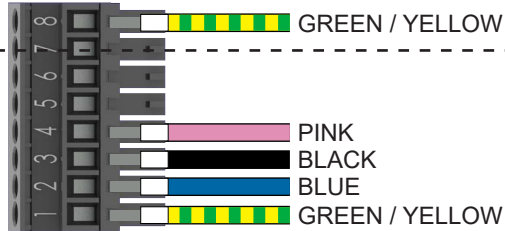
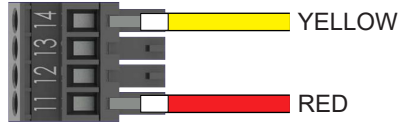

Coils Harness

Terminal	Port	Wire Color
8	4	Green/Yellow
11	4	Red
14	4	Yellow
Chassis Lug	4	Black

Electrodes Harness

Terminal	Port	Wire Color
1	5	Green/Yellow
2	5	Blue
3	5	Black
4	5	Pink

Pulse Output Harness

Terminal	Port	Wire Color
23	1	Pink
24	1	Brown
25	1	Yellow
26	1	Gray

4-20 mA Output Harness

Terminal	Port	Wire Color
21	1	White
22	1	Green

DC Power Harness

Terminal	Port	Wire Color
Negative	3	Black
Positive	3	Red

AC Power Harness

Terminal	Port	Wire Color
Ground	3	Green
Negative	3	White
Load	3	Black

To complete AC power connection, connect green grounding lug to chassis as shown on previous page.