

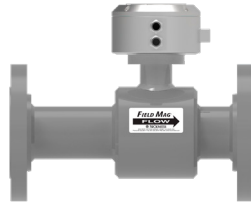

Field Mag 3000 Electromagnetic Flow Meter

Quick Start Installation Guide



About This Quick Start Guide

This Quick Start Guide is a supplement to the Installation, Operation and Maintenance manual supplied with this meter. It is intended to be a quick reference for the basic installation and reading of the Field Mag.

It is designed to provide installation instructions when the location of the sensor installation has been predetermined.

Refer to the meter manual (30126-45 Field Mag 3000 IOM manual) for information on these topics:

- Preparation and planning for installation
- Site location
- Software configuration
- Detailed information on external connections, external power, outputs

Standard Model

For use in non-hazardous locations

HL Model

For use in hazardous locations:

- Class I, Division 2, Groups A-D, T5
- Class I, Zone 2 IIC T5



WARNING!

Incorrect installation or removal of meters can result in serious injury or death. Read the instructions in this guide on the proper procedures carefully.

- Any person installing, inspecting, or maintaining a McCrometer flowmeter should have a working understanding of piping configurations and systems under pressure.
- Before adjusting or removing any meter, be certain the system has depressurized completely.
- Be careful when lifting meters. Meters can cause serious injury if lifted incorrectly or dropped.

About This Quick Start Guide.	1
1. Check Shipping Crate Contents	2
2. Check Serial Numbers	2
3. Pipe Run Requirements	2
4. Sensor Position and Location	2
5. Flow Meter Installation	3
6. Example Remote Mount Configuration	3
7. Installing Cables through Cable Glands and Conduit	4
8. Wiring Diagrams.	5
9. Grounding	6
10. Activating The Display.	7
11. Transmitter Boot	7
12. Transmitter Configuration	8
13. Error Messages for Troubleshooting	8

1. Check Shipping Crate Contents

The shipping crate contains the following items:

- Electromagnetic meter assembly with grounding wire attached
- Transmitter cable (attached to meter)
- ProComm Go transmitter
- Grounding rings (flanged meters only)
- Ground wires (2) (flanged meters only)
- User manuals for both the sensor and ProComm Go transmitter

When uncrating the Field Mag, any damage due to rough or improper handling should be reported to the transportation firm and McCrometer. If for any reason it is determined that the unit or parts of the unit should be returned to the factory, please contact McCrometer for clearance prior to shipment. Each unit must be properly crated to prevent any further damage. The factory assumes no responsibility for equipment damaged in return shipment due to improper packaging.

2. Check Serial Numbers

The transmitter and sensor are supplied as a matched system. Verify the meter serial numbers on both the transmitter and sensor match. This will insure a properly calibrated system.

The tag on the side of the transmitter has the transmitter model number, the transmitter serial number and the meter serial number, which is calibrated to the transmitter. An example is shown below.

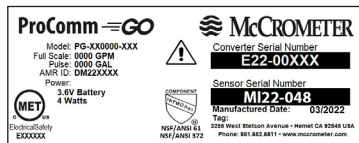

I IMPORTANT

Verify the meter serial numbers on both the transmitter and sensor match. This will insure a properly calibrated system. The meter serial number is located on a plate on the body of the sensor, and the transmitter serial number and the meter serial number are located on a label on the side of the transmitter. Insure the meter serial number on the sensor and the transmitter tags match.

3. Pipe Run Requirements

The meter needs to be located a minimum distance before and after flow disturbances, such as elbows, pumps, partially opened valves, and changes in pipe diameter. The uneven flow created by these obstructions can vary with each system.

The minimum distance is measured in pipe diameters (D). To ensure accuracy locate the sensor upstream and downstream of flow disturbances as follows:

2D upstream / 1D downstream

4. Sensor Position and Location

Pipe Diameters

For proper accuracies any 90 or 45 degree elbows, valves, partially opened valves etc. should be placed not closer than two pipe diameters upstream and one pipe diameter downstream.

Flow Direction

It is very important to install the flow meter relative to the flow of the water. There is a sticker on the Field Mag that indicates the direction of flow.

Sensor Orientation

The following installation recommendations should be followed (see next page):

Horizontal installation

In horizontal pipe runs, the meter should be installed so that the junction box is vertical insuring the electrodes are positioned to prevent coating by sediments or loss of electrode contact due to air bubbles.

Vertical installation

In vertical pipe runs, the flow should be upward. In slurry application, a vertical position ensures optimal distribution of solids under all flow conditions.

Less than full pipes

In pipes which may encounter less than a full pipe of fluid, the meter must be positioned in a trap to ensure that the sensor is always completely filled with liquid.

by the factory.) Clamps should be bolted on tight, but torquing is not required. Refer to section 9 for a full description of grounding methods that are available.

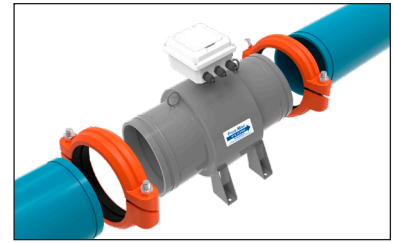

Flanged Meter Installation

Install the Field Mag flow meter inline between two flanged end pipes. The flow meter may require grounding, depending on the environment they are being installed in. Refer to section 9 for a full description of grounding methods that are available.

5. Flow Meter Installation

I The Field Mag requires grounding to ensure proper functioning and accuracy. See section 9 for grounding instructions and methods.

Meters with Grooved End Connections

Meters with grooved ends are easily installed by connecting two pipe ends to the meter body. Clamp the two ends using standard clamps used for this purpose. (Clamps are not provided

6. Example Remote Mount Configuration

You will need to prepare the location where you will install the remote transmitter. The location cannot be further from the flow meter than the length of the 25' cable. This must be planned in advance because the cable cannot be lengthened. Doing so will alter the calibration accuracy between the meter and the transmitter and void the warranty.

Install the flow meter as required. Mount the transmitter and connect the cable to the meter's junction box and the transmitter's external connection.

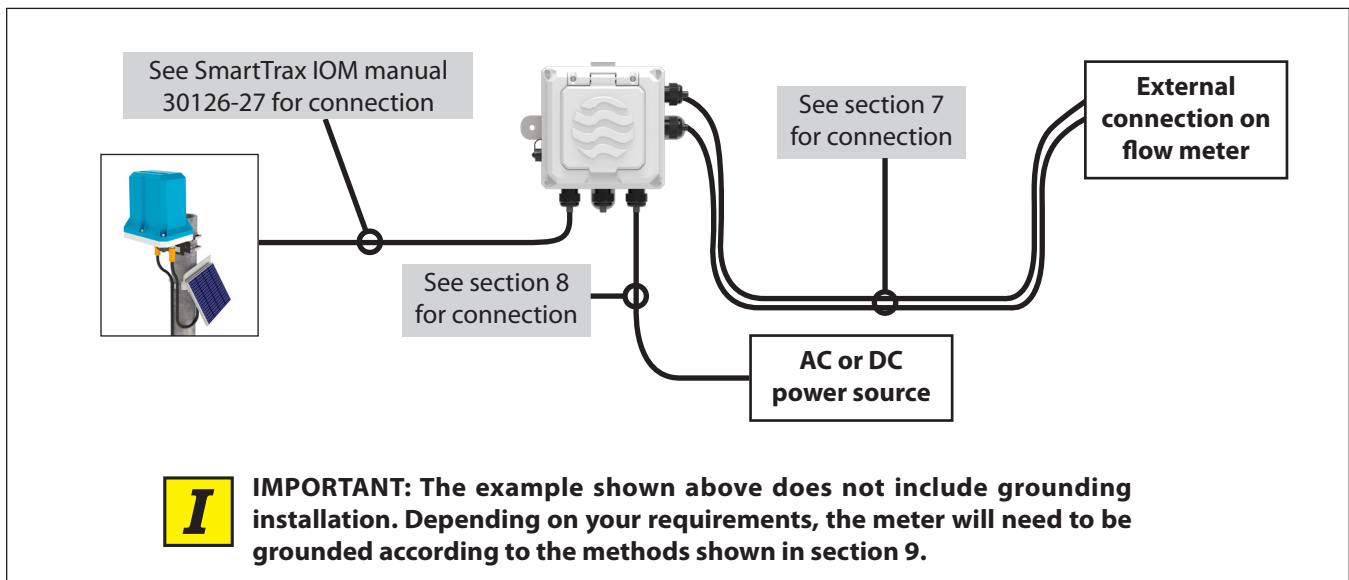

7. Installing Cables through Cable Glands and Conduit

All electrical cables enter the transmitter through compression fittings or optional customer-supplied conduit located on the side or bottom of the transmitter. Ensure that all compression glands are properly tightened and all unused fittings are plugged so the case remains sealed.

The power cable and wiring harnesses are each assigned specific cable glands where they will pass through into the transmitter. See below for cable gland assignment for wiring harnesses and wiring diagrams. All cable compression glands must be properly tightened to prevent moisture intrusion and maintain the IP67 rating. To insure IP67 rating, use only round cable 0.24" to 0.47" in diameter.

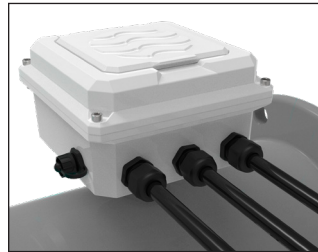

Standard cable gland



Quick connect connectors

Attaching conduit directly to the enclosure may introduce dangerous gasses and moisture into the enclosure creating a dangerous condition, and will remove the enclosure's IP67 rating.



Damage caused by attaching conduit to the enclosure or altering the enclosure in any way is not covered by the warranty.

Cable Gland Assignment for Wiring Harnesses

Port assignment

- 1 - Outputs
- 2 - Outputs
- 3 - Power
- 4 - Coils
- 5 - Electrodes

Meter mount view

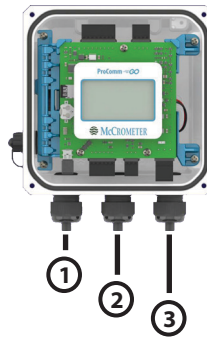

Remote mount view

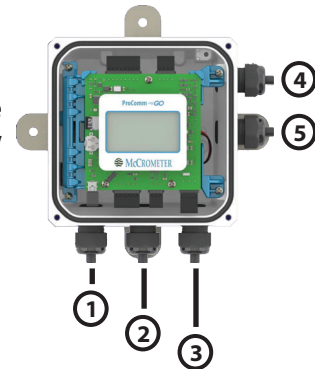

Terminal Block Diagram and Grounding Lug

See next page for wiring diagram for each terminal block.

Coils and electrodes

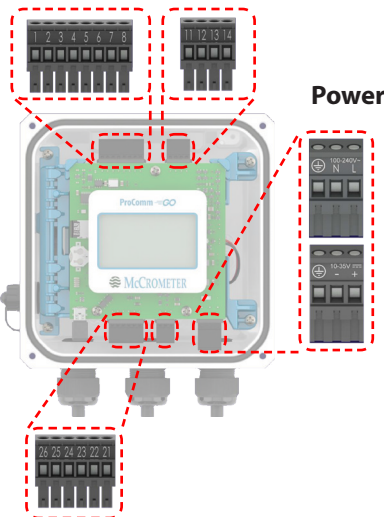

Pulse / 4-20 mA outputs

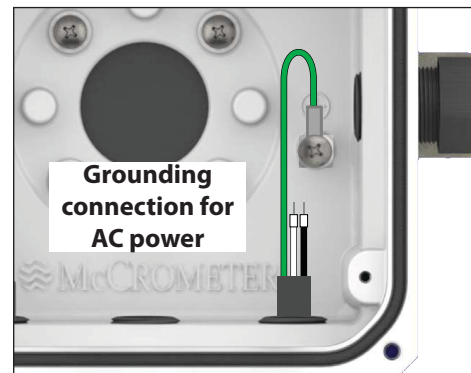

8. Wiring Diagrams

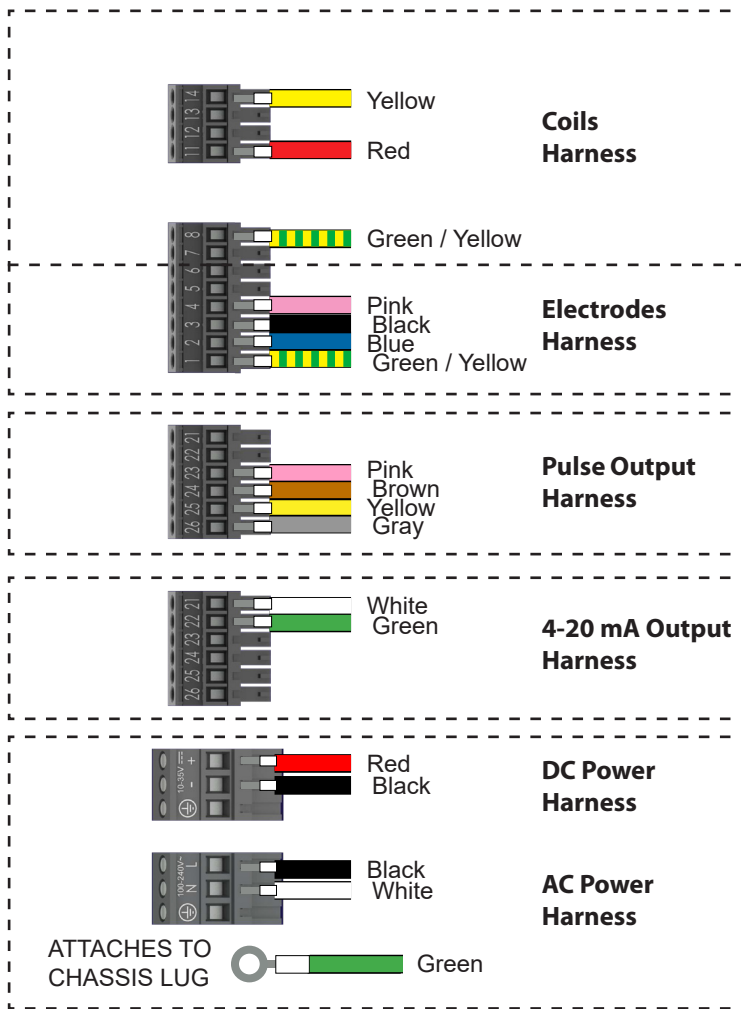

TERMINAL BLOCK ASSIGNMENTS

Terminal	Port	Wire Color
8	4	Green/Yellow
11	4	Red
14	4	Yellow

Terminal	Port	Wire Color
1	5	Green/Yellow
2	5	Blue
3	5	Black
4	5	Pink

Terminal	Port	Wire Color
23	1	Pink
24	1	Brown
25	1	Yellow
26	1	Gray

Terminal	Port	Wire Color
21	1	White
22	1	Green

Terminal	Port	Wire Color
Negative	3	Black
Positive	3	Red

Terminal	Port	Wire Color
Chassis lug	3	Green
Neutral	3	White
Load	3	Black

To complete AC power connection, connect green ground jumper as shown on the previous page.

9. Grounding

Grounding the meter body for safety according to national (NEC) or local electrical codes is recommended on ALL meter installations. All Field Mag flow meter installations require minimum grounding with a 12-gauge ground wire to an earth ground.

Flanged end meters

See below for grounding examples, including the preferred method of grounding.

When installing into a PVC or plastic pipe system, grounding rings for flanged meters are recommended for all sizes. For best performance, McCrometer provides grounding rings for all sizes.

For best performance, grounding the fluid column is recommended when the meter is installed in an electrically noisy environment, such as with VFD pumps or nearby electrical systems with insufficient grounding.

Grooved end meters

Grooved end meters do not require grounding rings and only require a ground wire connecting the ground lug to a ground.

Meter Grounding Recommendations

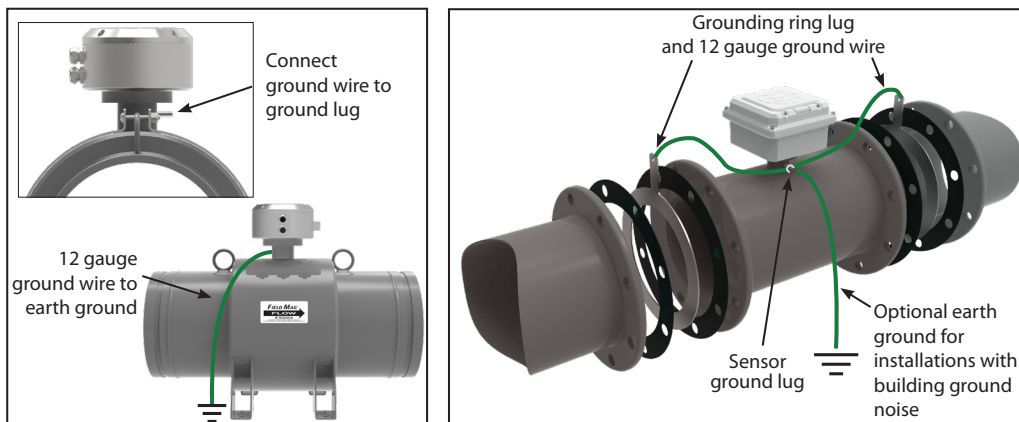

Recommended method of grounding

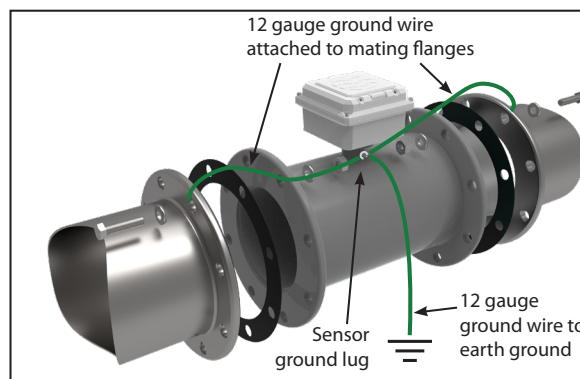

**Alternative method of grounding with
conductive or uncoated pipe**

10. Activating The Display

The display is activated when the lid is opened. The display will remain active for 30 seconds.

The various parts of the interface screen is shown below. Depending on how the transmitter is configured with the configuration tool the display will show either single direction or bidirectional total flow quantities. Bidirectional flows are represented as either positive (POS) or negative (NEG), as shown at right.

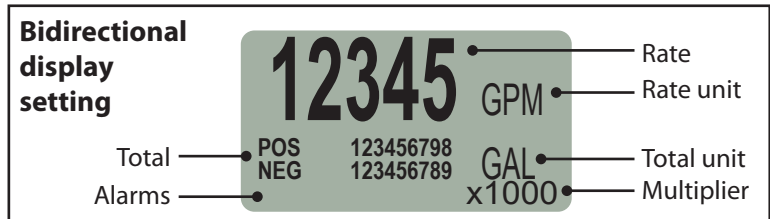
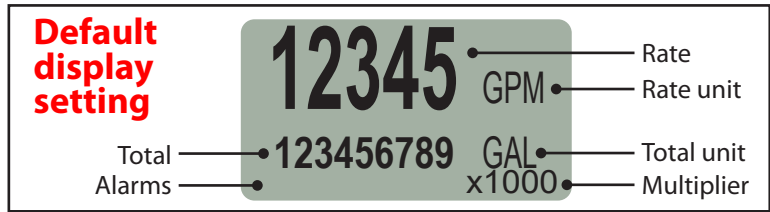

I CAUTION: If the lid is broken off, contact the Factory for a lid replacement kit. In the meantime, set the lid on the meter in its proper position and use the boot to hold it in place.

NOTE The transmitter display is light activated and requires a minimum amount of light to appear. Environments where light is low, such as in dimly lit buildings or outdoors after sundown may prevent the display from appearing when the lid is raised.



11. Transmitter Boot

The Field Mag comes with a boot to help protect the meter. The boot simply slips over the electronics enclosure. When installing the boot, ensure the corners of the boot fit snugly over the lip of the enclosure. To remove the boot, grip two corners and pull them away from the lip of the enclosure and then pull upwards.

I IMPORTANT It is HIGHLY recommended that the boot be utilized at all times when the meter is not being read. The boot adds protection to the meter and ensures proper closure of the lid, ensuring the maximum battery life.

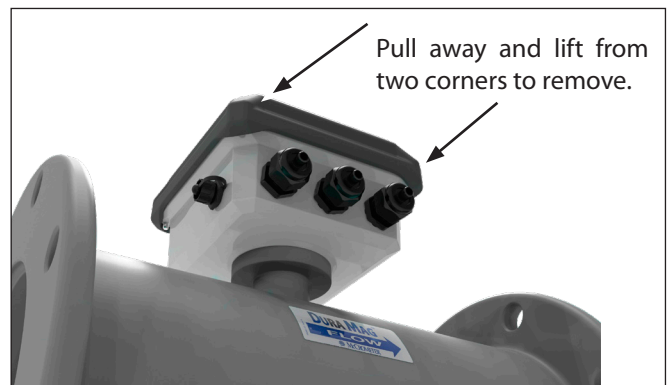
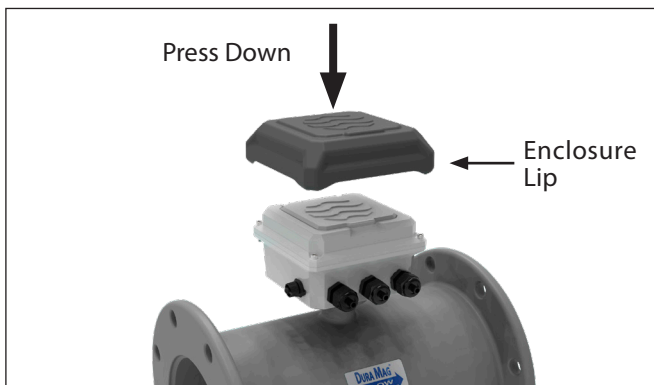

12. Transmitter Configuration

The transmitter can be programmed to customize how the data is measured and stored. The configuration tool runs only on Windows 7, 8, or 10 and requires a computer with a USB port. You must have your flow meter's serial number before you begin.

See the transmitter manual for instructions on using the configuration software.



13. Error Messages for Troubleshooting

DISPLAY MESSAGE	Troubleshooting
BAT LOW	Battery replacement Kit is needed to replace batteries. The batteries Should last approximately 6-9 months from the time the warning is shown.
420 ERR	The 4-20 circuit is not wired correctly. Check the wiring diagram and ensure 9-30VDC power is supplied to the circuit. The output is not source powered.
COIL XCT	There is an issue with the electro magnetic coils. Check that the internal wiring is correct in the transmitter for the coil wires.
ADC CLIP	The meter signal exceeds the limit of the transmitter, likely due to noise. Check the meter grounding meets the IOM guidelines and identify any sources of noise.
HIGH HUM	Humidity inside transmitter housing has exceeded limits. Check for any loose connections on transmitter housing that could be creating a leak.
COIN LOW	Datalogger time backup battery is low. This is part of the battery replacement kit and should be replaced with the main battery packs.