



Field Mag 3000 Electromagnetic Flow Meter

Installation, Operation and Maintenance Manual



Standard Model

For use in non-hazardous locations

HL Model

For use in hazardous locations:

- Class I, Division 2, Groups A-D, T4
- Class I, Zone 2 IIC T4

30126-45 Rev. 1.3
14JUL2025



Contents

- SAFETY..... 1**
 - Safety Symbols And Warnings 1
 - Safety Warnings 1
- 1.0 DESCRIPTION OF THE FLOW METER 2**
- 2.0 UNPACKING THE CRATE AND VERIFYING SERIAL NUMBERS 2**
 - 2.1 Uncrating 2
 - 2.2 Verifying the Serial Numbers 2
- 3.0 PREPARING FOR A NEW INSTALLATION..... 3**
 - 3.1 Sensor Location..... 3
 - 3.2 Remote Mount Converter Location..... 3
 - 3.3 Pipe Run Requirements 4
 - 3.4 Positioning and Orienting the Sensor 4
- 4.0 FLOW METER INSTALLATION 4**
 - 4.1 Installation for Meter with Grooved End Connections 4
 - 4.2 Installation for Meter with Flanged Ends..... 5
 - 4.3 Remote Mount Converter Installation 5
- 5.0 REMOTE MOUNT CONVERTER INSTALLATION..... 6**
 - 5.1 Mounting the ProComm GO Converter 6
 - 5.2 Installing Cables through Cable Glands and Conduit 6
 - 5.3 Pulling Sensor Cable Through Electrical Conduit 7
 - 5.4 Cable Gland Assignment for Wiring Harnesses 7
- 6.0 INTERNAL WIRE CONNECTION 8**
 - 6.1 Terminal Block Diagram and Grounding Lug 8
 - 6.2 Wiring Diagrams 9
 - 6.3 Connecting the SmartTrax Remote Transmitting Unit..... 10
 - 6.4 Pin-out of Male and Female Connectors 11
 - 6.5 Installing the Optional Solar Panel 11
- 7.0 EXTERNAL WIRE CONNECTION 12**
 - 7.1 Cable Gland Connections 12
 - 7.2 Quick Connect Cabled Ends (Optional) 12
 - 7.3 Power Options..... 14
 - 7.4 DC Power Cable (Optional)..... 14
 - 7.5 4-20mA Current Loop 14
 - 7.6 Pulse Output Cable (Optional) 14
 - 7.7 Solar Panel Option 15
- 8.0 GROUNDING AND ELECTRICAL INTERFERENCE 16**
 - 8.1 Sensor Grounding Methods 16
- 9.0 BATTERY REMOVAL AND REPLACEMENT 18**
- 10.0 OPERATION 22**
 - 10.1 General 22
 - 10.2 Activating the Display 22
 - 10.3 Converter Boot 22
- 11.0 CONVERTER CONFIGURATION 23**
- 12.0 ERROR MESSAGES FOR TROUBLESHOOTING..... 24**
- 13.0 REPLACEMENT PARTS..... 25**
- 14.0 SPECIFICATIONS..... 26**
 - 14.1 Flow Meter Specifications 26
 - 14.2 Flow Meter Dimensions and Weights 28
 - 14.3 ProComm GO Converter Specifications 31
 - 14.4 ProComm GO Converter Dimensions 33
- 15.0 RETURNING A UNIT FOR REPAIR 34**
- WARRANTY..... 35**

SAFETY

Safety Symbols And Warnings

Throughout this manual are safety warning and caution information boxes. Each warning and caution box will be identified by a large symbol indicating the type of information contained in the box. The symbols are explained below:



This symbol indicates important safety information. Failure to follow the instructions can result in serious injury or death.



This symbol indicates important information. Failure to follow the instructions can result in permanent damage to the meter or installation site.

Safety Warnings

When installing, operating, and maintaining McCrometer equipment where hazards may be present, you must protect yourself by wearing Personal Protective Equipment (PPE) and be trained to enter confined spaces. Examples of confined spaces are manholes, pumping stations, pipelines, pits, septic tanks, sewage digesters, vaults, degreasers, storage tanks, boilers, and furnaces.

You must follow all state and local laws, as well as Occupational Safety and Health Administration (OSHA) regulations concerning Personal Protective Equipment and confined-space entry. Specific requirements can be found in the OSHA section of the Code of Federal Regulations: 29 CFR, 1910.132 - 1910.140, *Personal Protective Equipment*; and CFR Title 29, Part 1910.146, *Permit-Required Confined-Spaces*.



WARNING!

Incorrect installation or removal of meters can result in serious injury or death. Read the instructions in this manual on the proper procedures carefully.



WARNING!

Never enter a confined space without testing the air at the top, middle, and bottom of the space. The air may be toxic, oxygen deficient, or explosive. Do not trust your senses to determine if the air is safe. You cannot see or smell many toxic gases.



WARNING!

Never enter a confined space without the proper safety equipment. You may need a respirator, gas detector, tripod, lifeline, and other safety equipment.



WARNING!

Never enter a confined space without standby/rescue personnel within earshot. Standby/rescue personnel must know what action to take in case of an emergency.

1.0 DESCRIPTION OF THE FLOW METER

Ultra Mag meters are available with integral or remote mount converters. Standard display features include forward, reverse and net flow totalizers, flow rate, alarm monitoring, and automatic self diagnostics to ensure integrity. All data and values are in selectable units of measurement. System compatibility is assured with a choice of current, pulse and serial data. Please refer to the converter manual provided with your meter.

Ultra Mag operating parameters are set via the electronics keypad. The software features multilevel password protection capability to prevent inadvertent program or setting changes. Data is stored in nonvolatile memory.

The flanged end tube design permits use in a wide range of applications. The fabricated tube is stainless steel with steel or stainless steel flanges and incorporates the UltraLiner, an NSF approved fusion-bonded epoxy liner.

2.0 UNPACKING THE CRATE AND VERIFYING SERIAL NUMBERS

2.1 Uncrating

The shipping crate contains the following items:

- Electromagnetic meter assembly with grounding wire attached
- Converter cable (attached to meter)
- Signal converter
- Grounding rings
- Ground wires (2)
- User manuals for both the sensor and converter

When uncrating the Ultra Mag, any damage due to rough or improper handling should be reported to the transportation firm and McCrometer. If for any reason it is determined that the unit or parts of the unit should be returned to the factory, please contact McCrometer for clearance prior to shipment. Each unit must be properly crated to prevent any further damage. The factory assumes no responsibility for equipment damaged in return shipment due to improper packaging.

2.2 Verifying the Serial Numbers

The converter and sensor are supplied as a custom calibrated matched system. Verify the system serial numbers on both the converter and sensor match. This will ensure a properly calibrated system.

The meter serial number is located on the side of the sensor body on a silver label. An example is shown below (Figure 1).

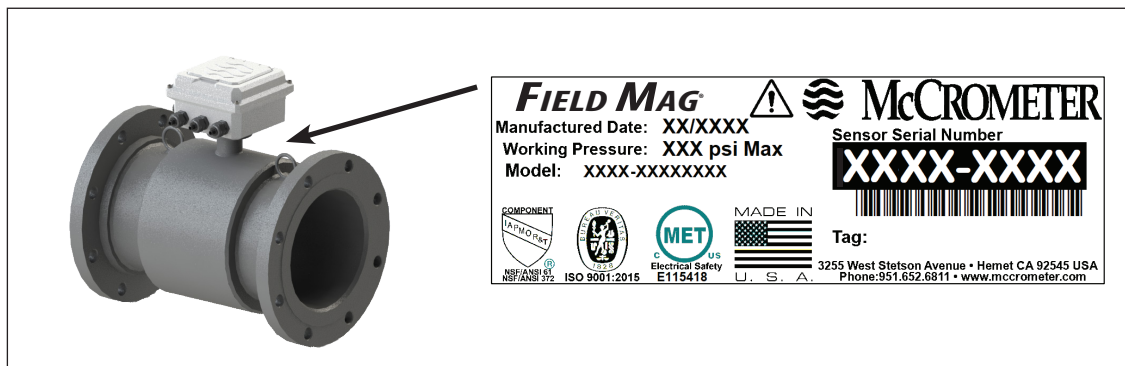

Figure 1. Flow meter serial number tag

I IMPORTANT: Verify the meter serial numbers on both the converter and sensor match. If the meter serial numbers do not match, contact the factory before continuing with the installation.

The serial number tag is located on the side or top of the converter (Figure 2). The tag has the converter model number, the converter serial number, the meter model number and the meter serial number. Examples are shown below (Figure 3 and Figure 4).



Figure 2. Serial number tag locations for meter mount and remote mount converters



Figure 3. Serial number tag for standard model



Figure 4. Serial number tag for hazardous location model

3.0 PREPARING FOR A NEW INSTALLATION

3.1 Sensor Location

Adjoining pipe must be adequately supported, and the area around the sensor should provide sufficient drainage to prevent flooding the converter or conduits. The location chosen should provide room to read the display and be free from harsh electrical noise from adjacent equipment, cables, R.F.I., or E.M.I. The signal converter should not be subjected to intense, prolonged sunlight and/or vibrations. Unit should also be protected from heat.

3.2 Remote Mount Converter Location

The signal converter may be installed in a desired location provided that free access is available to allow the display to be viewed as required. The unit can be either wall mounted or panel mounted with masonry fixings or nuts and bolts respectively via the fixing holes provided. The maximum distance between the meter and the converter is 25 feet. For applications with extended lengths, consult factory.

3.3 Pipe Run Requirements

The meter needs to be located a minimum distance before and after flow disturbances, such as elbows, pumps, partially opened valves, and changes in pipe diameter. The uneven flow created by these obstructions can vary with each system. McCrometer recommends meters be installed with disturbances no less than 2D upstream and 1D downstream. See Figure 5 at right.

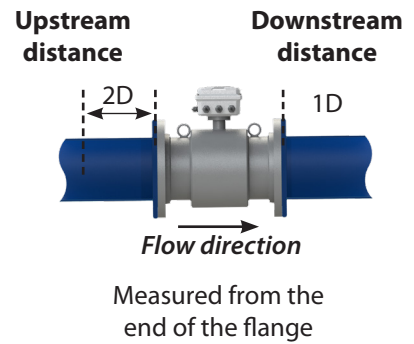

Figure 5. Upstream and downstream requirements

3.4 Positioning and Orienting the Sensor

The following installation recommendations should be followed (see Figure 6 for installation diagrams):

Horizontal installation

In horizontal pipe runs, the meter should be installed so that the junction box is vertical insuring the electrodes are positioned to prevent coating by sediments or loss of electrode contact due to air bubbles. See Figure 5 above.

Vertical installation

In vertical pipe runs, the flow should be upward. In slurry application, a vertical position ensures optimal distribution of solids under all flow conditions.

Less than full pipes

In pipes which may encounter less than a full pipe of fluid, the meter must be positioned in a trap to ensure that the sensor is always completely filled with liquid.

4.0 FLOW METER INSTALLATION

NOTE Nothing in this manual supersedes local codes.

NOTE The flow of the medium should correspond to the direction shown by the arrow on the sensor.

4.1 Installation for Meter with Grooved End Connections

Meters with grooved ends are easily installed by connecting two pipe ends to the meter body. Clamp the two ends using standard clamps used for this purpose. (Clamps are not provided by the factory.) Clamps should be bolted on tight, but torquing is not required. Refer to section 8.0 for a full description of grounding methods that are available.



Figure 6. Grooved end meter installation

4.2 Installation for Meter with Flanged Ends

Install the Ultra Mag flow meter inline between two flanged end pipes. The flow meter may require grounding, depending on the environment they are being installed in. Refer to section 8.0 for a full description of grounding methods that are available.

4.3 Remote Mount Converter Installation

You will need to prepare the location where you will install the remote converter. The location cannot be further from the flow meter than the length of the 25' cable. This must be planned in advance because **the cable cannot be lengthened**. Doing so will alter the calibration accuracy between the meter and the converter and void the warranty.

Install the flow meter as described in section 4.1 or 4.2. Mount the converter and connect the cable to the meter's junction box and the converter's external connection. Figure 7 below shows an example of a remote mount installation with an optional Smart Output connection.

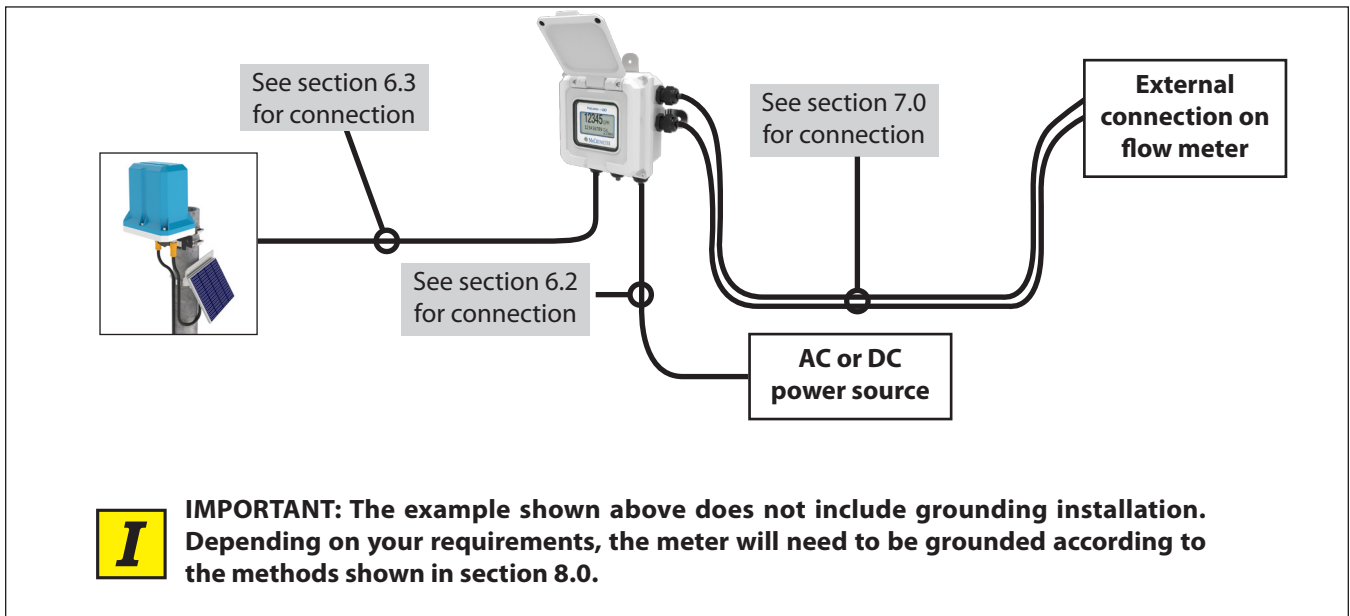

Figure 7. Example remote mount configuration

5.0 REMOTE MOUNT CONVERTER INSTALLATION

5.1 Mounting the ProComm GO Converter

Note: This applies to the remote mount converter only.

If possible, mount the converter in an electronics shed or environmental enclosure. The sun shield should be oriented in a direction to reduce sun damage and ensure readability. This electronic unit is rated IP67 for temporary flooding.

There is a stainless steel mounting plate attached to the back of the ProComm GO converter, which is used to mount the converter to a solid, flat surface using four bolts (Figure 8). Mounting plate feet are located at the top, bottom, left, and right sides.

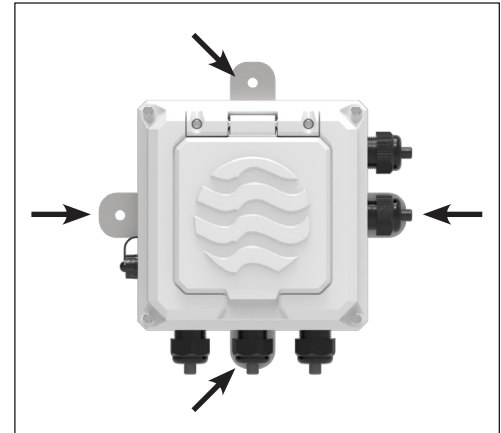

Figure 8. Mounting converter to solid surface

5.2 Installing Cables through Cable Glands and Conduit

All electrical cables enter the converter through compression fittings or optional customer-supplied conduit located on the side or bottom of the converter (Figure 9 and Figure 10). Ensure that all compression glands are properly tightened and all unused fittings are plugged so the case remains sealed.

The power cable and wiring harnesses are each assigned specific cable glands where they will pass through into the converter. See section 5.4 for cable gland assignment for wiring harnesses and section 6.2 for wiring diagrams.

All cable compression glands must be properly tightened to prevent moisture intrusion and maintain the IP67 rating. To insure IP67 rating, use only round cable 0.24" to 0.47" in diameter.



Figure 9. Compression fittings

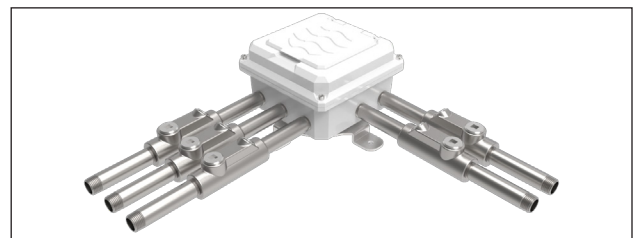

Figure 10. Remote mount converter with conduit pass-throughs



WARNING

Attaching conduit directly to the enclosure may introduce dangerous gasses and moisture into the enclosure creating a dangerous condition, and will remove the enclosure's IP67 rating. **Damage caused by attaching conduit to the enclosure or altering the enclosure in any way is not covered by the warranty.**



WARNING

EXPLOSION HAZARD. DO NOT REMOVE OR REPLACE LAMPS, FUSES OR PLUG-IN MODULES (AS APPLICABLE) UNLESS POWER HAS BEEN DISCONNECTED OR THE AREA IS FREE OF IGNITABLE CONCENTRATIONS.



WARNING

EXPLOSION HAZARD. DO NOT DISCONNECT WHILE THE CIRCUIT IS LIVE OR UNLESS THE AREA IS FREE OF IGNITABLE CONCENTRATIONS.



IMPORTANT: Do not cut or alter the cable length on power or signal cables!

Connections to the sensor must be made with cable supplied by McCrometer specifically for that purpose. Do not substitute the supplied cable with other types of cable, even for short runs. For repairs or added lengths of cable, the entire cable between the sensor and the converter must be replaced. (Consult factory for replacement cable.)

5.3 Pulling Sensor Cable Through Electrical Conduit

It is very important to protect the end of the sensor cable when pulling it through a conduit. Water can accumulate in low portions of conduit. Always use a cable cover, or similar method, to seal the end of the cable against water when pulling the cable through conduit (see Figure 11). This will ensure proper operation of the meter.

NOTE Cable cover is not provided.

1. Tie a rope or cable-snake securely around the middle of the cable cover.
2. Carefully pull the rope or snake until the sensor cable end clears the conduit.
3. Bring the cable end to the converter location. If necessary, secure the cable so that it does not fall back through the conduit.
4. Remove the cable cover by pulling the rip wire. The cable cover will tear off (discard the cover).

I CAUTION: Do not cut the cable cover off. Doing so may damage the sensor cable and adversely effect the calibration of the meter.

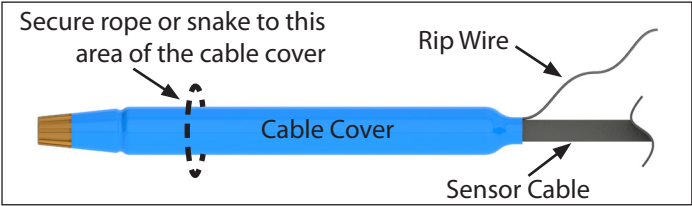

Figure 11. Cable cover

5.4 Cable Gland Assignment for Wiring Harnesses

Port assignment

- 1 - Outputs
- 2 - Outputs
- 3 - Power
- 4 - Coils
- 5 - Electrodes

Figure 12. Meter mount view

Figure 13. Remote mount view

6.0 INTERNAL WIRE CONNECTION

This section describes cable and wire harness connection inside the converter. Section 7.0 describes wire connection for all peripherals outside of the converter, including pulse output and external power options.

6.1 Terminal Block Diagram and Grounding Lug

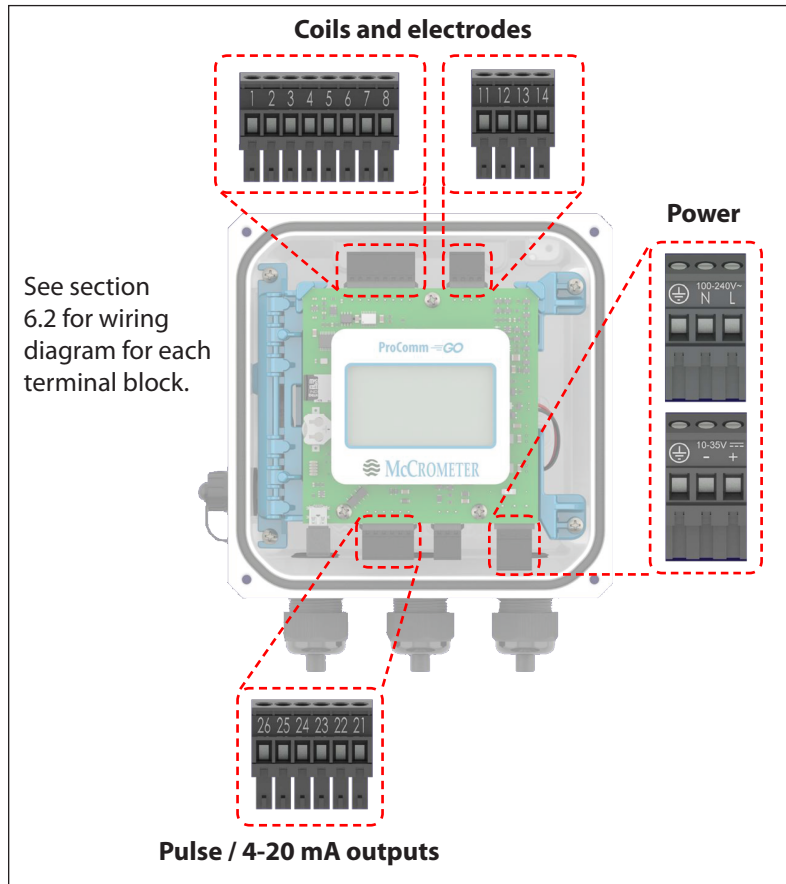

Figure 14. Terminal blocks

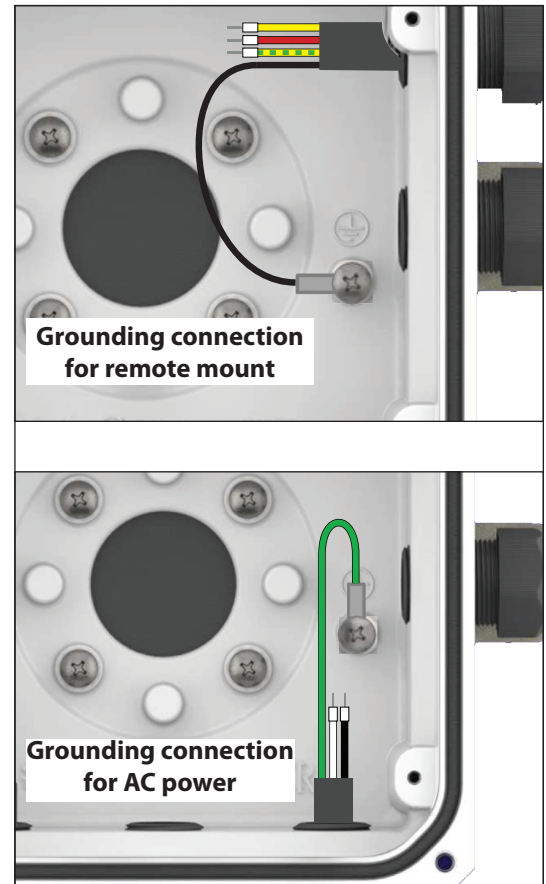
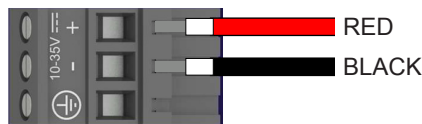
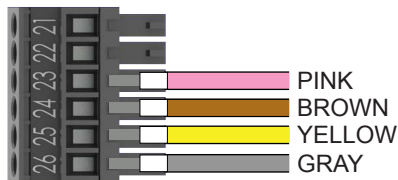
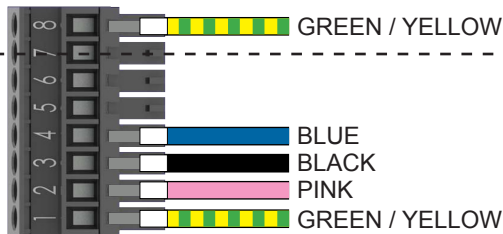
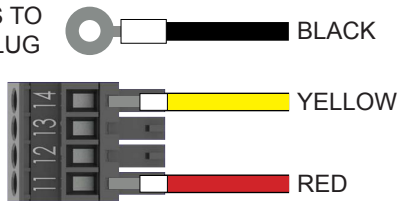

Figure 15. Grounding lug

6.2 Wiring Diagrams

TERMINAL BLOCK ASSIGNMENTS

ATTACHES TO
CHASSIS LUG



ATTACHES TO
CHASSIS LUG



Coils Harness

Terminal	Port	Wire Color
8	4	Green/Yellow
11	4	Red
14	4	Yellow
Chassis Lug	4	Black

Electrodes Harness

Terminal	Port	Wire Color
1	5	Green/Yellow
2	5	Pink
3	5	Black
4	5	Blue

Pulse Output Harness

Terminal	Port	Wire Color
23	1	Pink
24	1	Brown
25	1	Yellow
26	1	Gray

4-20 mA Output Harness

Terminal	Port	Wire Color
21	1	White
22	1	Green

DC Power Harness

Terminal	Port	Wire Color
Negative	3	Black
Positive	3	Red

AC Power Harness

Terminal	Port	Wire Color
Ground	3	Green
Negative	3	White
Load	3	Black

To complete AC power connection, connect green grounding lug to chassis as shown on previous page.

6.3 Connecting the SmartTrax Remote Transmitting Unit

The SmartTrax remote transmitting unit will need to be installed remotely from the converter, regardless of whether the converter is mounted directly on the sensor or installed remotely from the sensor. Use the output converter port to run the cable through (section 5.3).

The example configuration in section 4.3 shows the SmartTrax with an optional solar panel. If you use a solar panel or an external AC or DC power source, you will need to use the female connection shown in Figure 16 and Figure 17.

For specific wiring diagrams to connect the transmitter to the converter, see Figure 18 and Figure 19.

For more detail on the SmartTrax transmitter, including specifications, installation requirements, location, and remote data access, see the SmartTrax Installation, Operation, and Maintenance manual, 30125-82.

All Field Mag 3000 meters come software-preconfigured to accept SmartTrax in the future. When a SmartTrax unit is purchased, simply mount the unit as directed and wire the unit as indicated in the SmartTrax documentation. No specific options need to be selected at the time of order of the Field Mag 3000 meter.

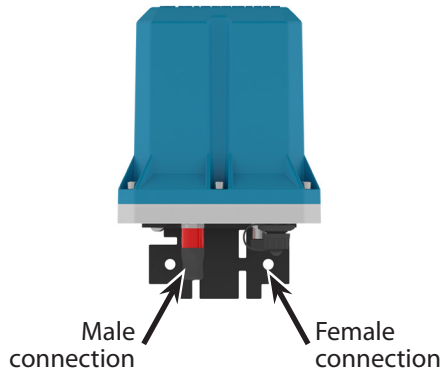

Figure 16. Connections, front view

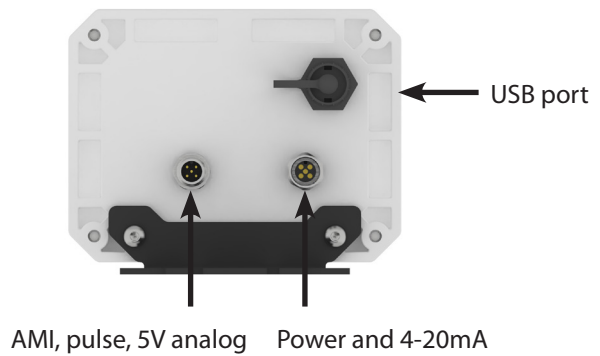

Figure 17. Connections, bottom view

6.4 Pin-out of Male and Female Connectors

FEMALE CABLE
4-20mA & Power Connector



Figure 18. Pin-out of Female Connector

PULSE 1 & 2	
PULSE 1	BLACK
PULSE 2	BROWN
GROUND	GRAY

AMI		
FUNCTION	COLOR	TERMINAL*
DATA	BLACK	33
CLOCK	BROWN	32
GROUND	GRAY	31

5V ANALOG	
5V OUTPUT	WHITE
ANALOG IN	BLUE
GROUND	GRAY

* Indicates terminal on PCB (page 8).

MALE CABLE
Pulse / AMI / 5V Analog Connector



Figure 19. Pin-out of Male Connector

4-20mA	
4-20mA -	WHITE
4-20mA +	BROWN

DC POWER / SOLAR	
9-30 VDC+	BLUE
GROUND / V-	BLACK

6.5 Installing the Optional Solar Panel

The optional solar panel can be installed as shown in Figure 20. There are two panel sizes with nominal power rated as 2.4W and 5.1W respectively. Do not use the optional solar panel used to provide power to the ProComm GO converter.

Install the solar panel adjacent to the SmartTrax unit so that the two can be connected with the 6' cable. Connect the cable from the solar panel to the female connection (Figure 16).

If the cable is not connected to the solar panel, refer to the wiring diagram shown in Figure 18 and Figure 19.



Figure 20. SmartTrax with attached solar panel

7.0 **EXTERNAL WIRE CONNECTION**

7.1 **Cable Gland Connections**

10-35VDC Power/4-20mA Output And Pulse Output

The flow meter has one dedicated port and two optional ports on the back side of the electronics enclosure. The dedicated port (center) is used to download data logger information or for meter service and troubleshooting. The two optional ports are for:

1. Optional 10-35 VDC power and 4-20mA output
2. Optional pulse outputs (flow volume and alarms)
3. AMI output
4. 100-240 VAC power

The flow meter is configured at the Factory for the optional outputs and requested by the customer at the time of order. The external cables attach through a permanent cable gland (standard, Figure 21) or through a screw locking-type waterproof connector (quick connect option, Figure 22 - see next section).

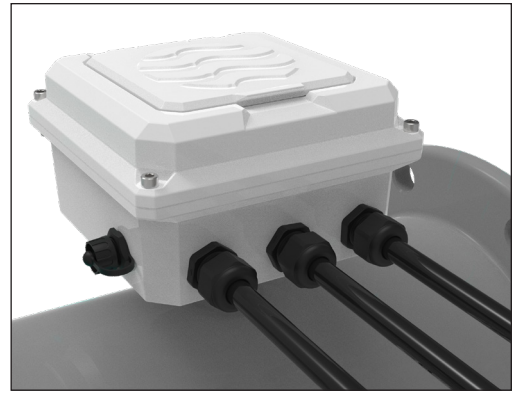

Figure 21. Standard cable gland

7.2 **Quick Connect Cabled Ends (Optional)**



IMPORTANT

Connections to the sensor must be made with cable supplied by McCrometer specifically for that purpose. Do not substitute the supplied cable with other types of cable, even for short runs. For repairs or added lengths of cable, the entire cable between the sensor and the converter must be replaced. (Contact factory for replacement cable.)

When quick connect cables are used both the meter and converter must have connector ports. See Figure 22 and Figure 23 for examples.

Quick Connect cable end fittings are optional. If selected at the time of order, follow the instructions below:

1. Remove the protective caps from both the receiving ports and the cable ends.
2. Insert the cable end into the port until fully seated, then turn the knurled collar on the cable to the right until the cable is tight.
3. With both cables properly attached to the meter, connect the meter-end protective cap to the cable-end protective cap. This insures that the protective caps remain free from dirt.

To remove cables:

1. Turn the knurled collar on the cable to the left until it is completely detached.
2. Replace the protective cap firmly on the connector port.



IMPORTANT

To connect sensor and converter via quick connect plugs and sockets, only use the supplied cable assemblies from McCrometer.



IMPORTANT

When not in use, always keep the attached cap firmly screwed into the connector to insure a water-tight seal. Also, keep the contacts in the cable connector clean and dry during assembly.



WARNING

EXPLOSION HAZARD. DO NOT CONNECT/DISCONNECT CONNECTORS OR WIRING OR REMOVE ENCLOSURE LID WHILE WITHIN AN ELECTRICALLY CLASSIFIED HAZARDOUS AREA.

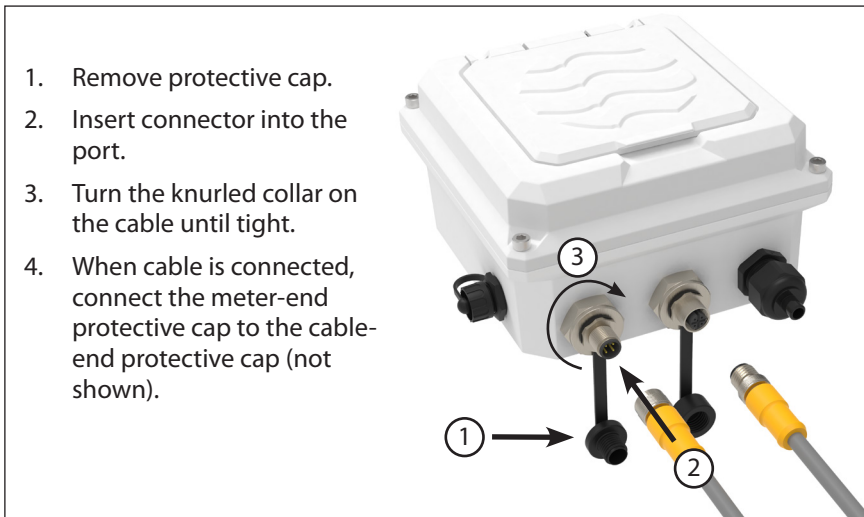

1. Remove protective cap.
2. Insert connector into the port.
3. Turn the knurled collar on the cable until tight.
4. When cable is connected, connect the meter-end protective cap to the cable-end protective cap (not shown).

Note: Exact location of connectors may depend on converter configuration.

Figure 22. Converter optional quick connect cable ends

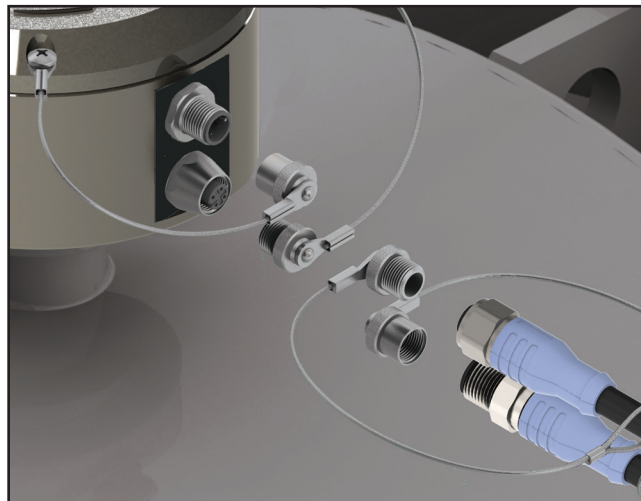

Figure 23. Ultra Mag junction box with optional quick connect cable ends

7.3 Power Options

Depending on output options and specific application position, you may choose to add additional power options to the battery powered converter. The 5W solar panel option (described in section 7.7) can extend battery life to 10-15 years. Additionally, you have the option of connecting external power of 10-32VDC or 100-240VAC.

7.4 DC Power Cable (Optional)

The cable contains wiring for both the optional 10-32VDC power to the meter, and the 4-20mA output from the meter. (Figure 24)

Note: Input power is for the converter only if that option was selected at time of purchase. The 4-20mA loop requires its own power supplied to the loop, not be used with red/black wires.

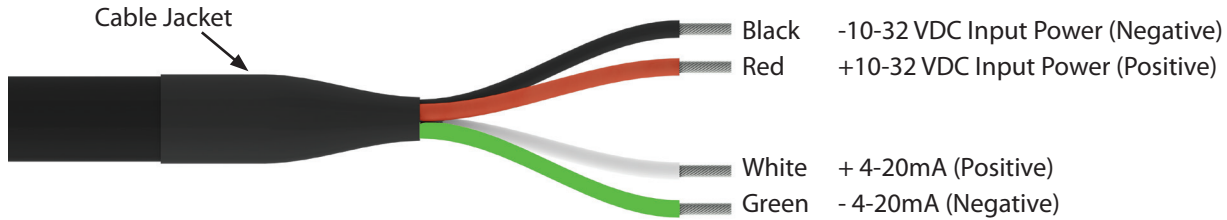

Figure 24. DC power cable wiring color scheme (optional)

7.5 4-20mA Current Loop

Output type: Passive 4-20mA current loop

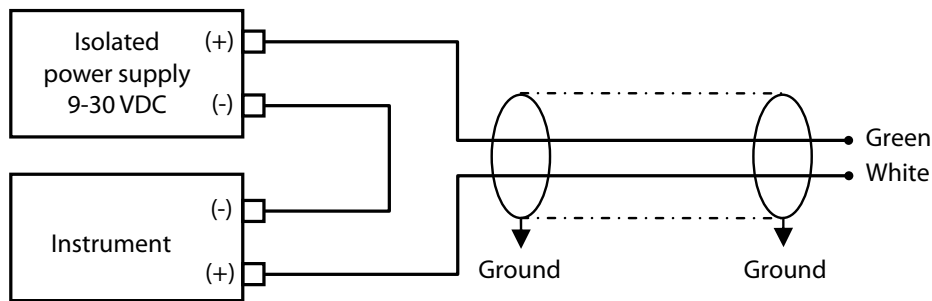

Figure 25. Passive 4-20mA current loop

7.6 Pulse Output Cable (Optional)

The cable contains wiring for both pulse output 1 and pulse output 2. (Figure 26 and Figure 27)

- Pink + Pulse Output 2 (Positive)
- Grey + Pulse Output 1 (Positive)
- Yellow - Pulse Output 1 & 2 (Negative)

Figure 26. Quick connect pulse output cable wiring color scheme (optional)

- Pink + Pulse Output 2 (Positive)
- Grey + Pulse Output 1 (Positive)
- Yellow - Pulse Output 1 (Negative)
- Brown - Pulse Output 2 (Negative)

Figure 27. Hard wired pulse output cable wiring color scheme (optional)

7.7 Solar Panel Option

The solar panel provides power to the converter by converting sunlight into electrical energy to recharge the solar panels' rechargeable battery. Its nominal power output is 5W.

When the solar panel is installed and the cable has been run to the converter, connection inside the converter is the same as installing batteries. See Figure 29 below.

The solar panel comes complete with all accessories, except for the fixing rod.

Solar panel cable enters the converter through port 3 (as shown above) and plugs into connector B1. Triple D pack battery plugs into B2 (as shown below). See battery installation and replacement procedure in section 9.0 for more detail.



These instructions apply only to McCrometer-supplied solar panels with a rechargeable battery. Connecting directly to a solar panel could damage the transmitter.

1. Remove lid from converter base.
2. Rotate battery tray open.
3. Route solar panel output cable through the bottom left strain relief.
4. Secure strain relief on the shrink wrap (Detail A) to avoid leaks.
5. Plug solar panel output cable into battery terminal 1 (BAT1).
6. Plug triple D battery pack into battery terminal 2 (BAT2).
7. Close battery tray.

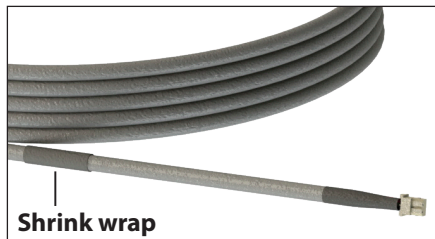
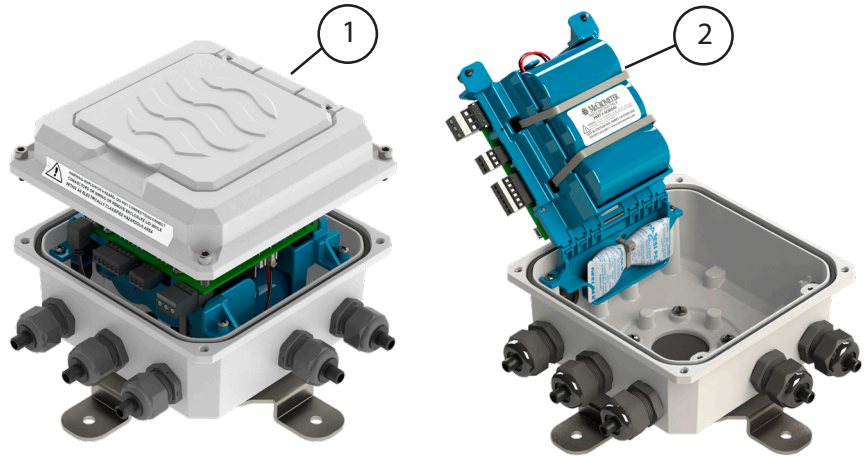

Detail A

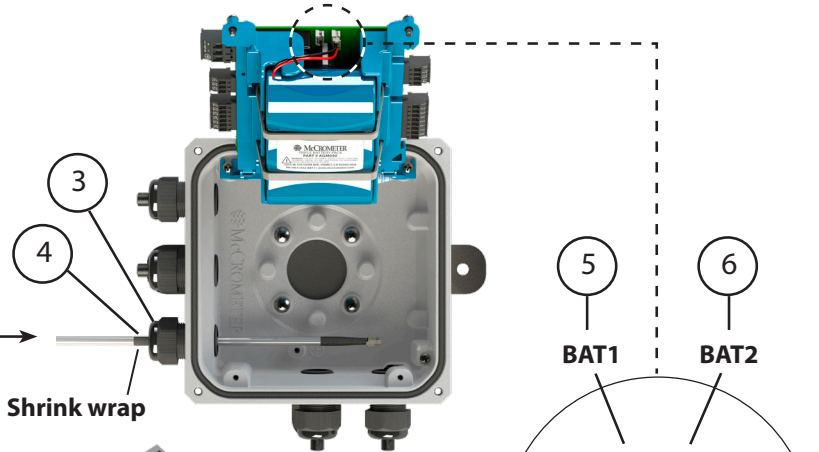

Shrink wrap

BAT1 BAT2

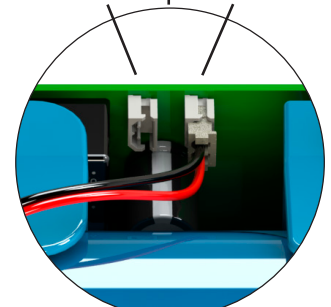

Detail B

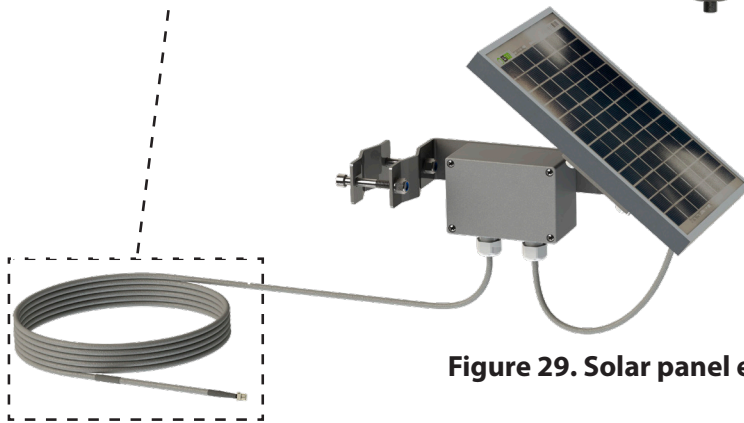

Figure 29. Solar panel electrical connection in converter

8.0 **GROUNDING AND ELECTRICAL INTERFERENCE**

I **NOTE:** On meters installed on a line with cathodic protection it may be necessary to insulate the meter from the line. Consult your cathodic protection vendor for instructions.

Always ensure that the converter and the sensor are grounded (earthed) correctly. The grounding of the sensor and converter ensures that the equipment and liquid have an equal potential. For most installations the quality of grounding by the provided cabling assures the sensor is properly grounded and additional grounding of the sensor is not required. However, in instances where this is not the case, i.e. the equipment and fluid do not have an equal potential, such as where the installation location and/or media is subjected to electrical interference, additional grounding steps may be required. Consult an electrician experienced with instrumentation installations to determine if electrical interference is present.

I **Information For Grounding Ring Installations**

- Gaskets must be used on either side of the grounding ring to provide a proper seal on the flanges. One gasket is used on flanges without a grounding ring.
- Rings & gaskets must align concentrically with the pipe so they do not obstruct or affect flow through the tube.
- The two grounding rings and four gaskets require an additional installation width of 0.375”.

8.1 **Sensor Grounding Methods**

Grounding the meter body for safety according to national (NEC) or local electrical codes is recommended on ALL meter installations.

All Ultra Mag flow meter installations require minimum grounding with a 12-gauge ground wire to an earth ground.

Flanged end meters

See Figure 28 for grounding examples, including the preferred method of grounding.

When installing into a PVC or plastic pipe system, grounding rings for flanged meters are recommended for all sizes. Flanges on the Ultra Mag sensor have a non-conductive coating and may not require grounding rings. For best performance, McCrometer provides grounding rings for all sizes.

For best performance, grounding the fluid column is recommended when the meter is installed in an electrically noisy environment, such as with VFD pumps or nearby electrical systems with insufficient grounding.

Grooved end meters

Grooved end meters do not require grounding rings and only require a ground wire connecting the ground lug to a ground.

Meter Grounding Recommendations

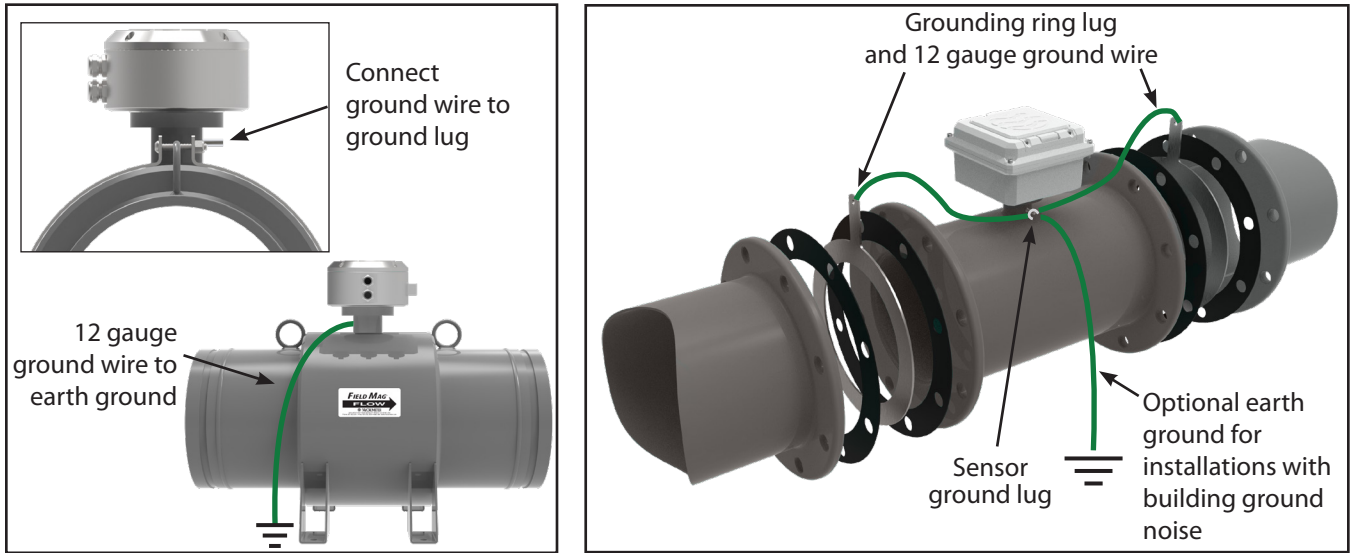

Recommended method of grounding

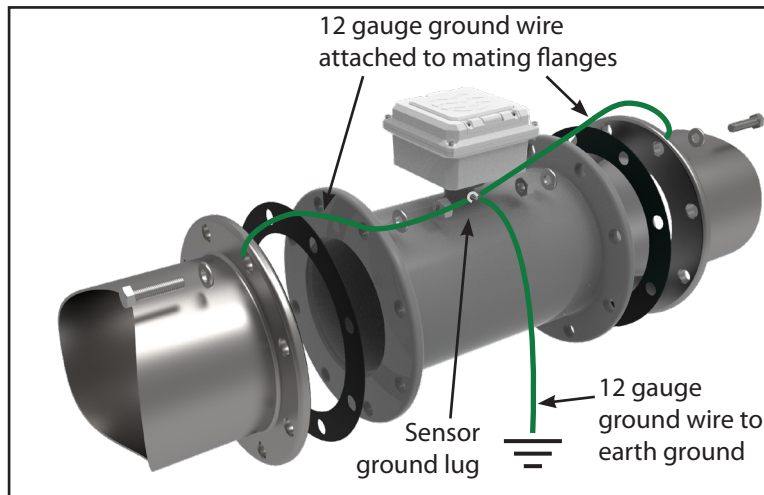

**Alternative method of grounding with
conductive or uncoated pipe**

Figure 28. Recommended and alternative methods of grounding

9.0 BATTERY REMOVAL AND REPLACEMENT

This procedure applies to all flow meters with the ProComm GO converter. It describes how to install batteries in a new meter and how to replace batteries using the replacement battery kit PGK01.



WARNING
EXPLOSION HAZARD. DO NOT DISCONNECT WHILE THE CIRCUIT IS LIVE OR UNLESS THE AREA IS FREE OF IGNITABLE CONCENTRATIONS.

Before you begin:

Check materials and tools to ensure you have everything you need.

Materials Provided (shown in order of use)

One triple D battery pack



One double A battery pack



Replacement cover gasket



Molykote lubricant



Zip ties:
• 2 large
• 1 small



Dry pack



Tamper proof wire seal

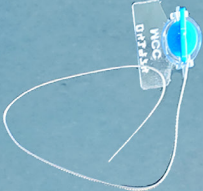

Tool Required

Wire cutters
Phillips screwdriver
5/32" Allen driver



I. Removing the cover

- Cut off the tamper-proof seal and remove the wire from the security screw.
NOTE: This step is not required for battery installation in new meters.

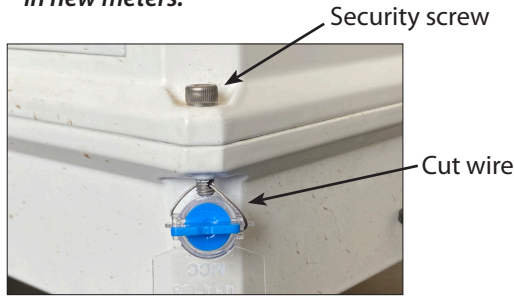

- Remove screws holding the lid to the housing using a 5/32" Allen driver. Lift the lid up and place the lid upside hanging by the green ground wire.



If you are replacing batteries with fresh batteries, continue to step 3.

If you are installing batteries in a new meter that does not have batteries already installed, go to step 9.

II. Removing the batteries

- Unplug tall connectors to sensor, outputs, and power.

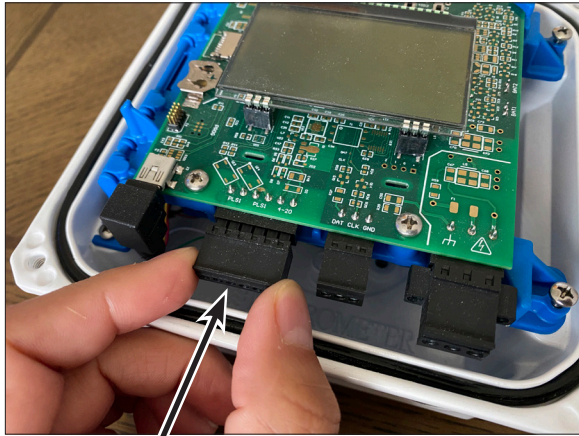

Connectors

- Loosen the captive screws opposite of the hinge and lift the battery cover.

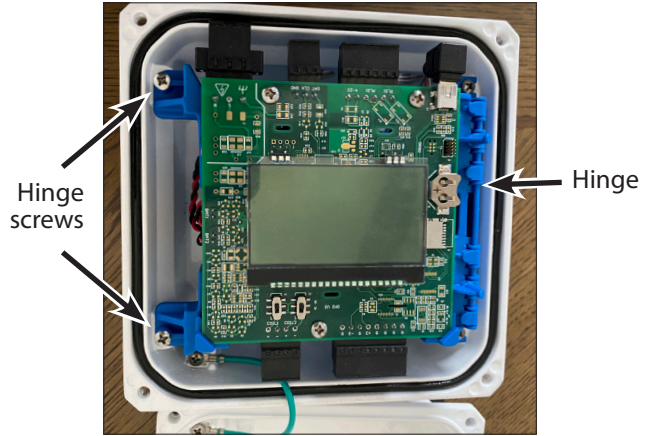

- Unplug the batteries.

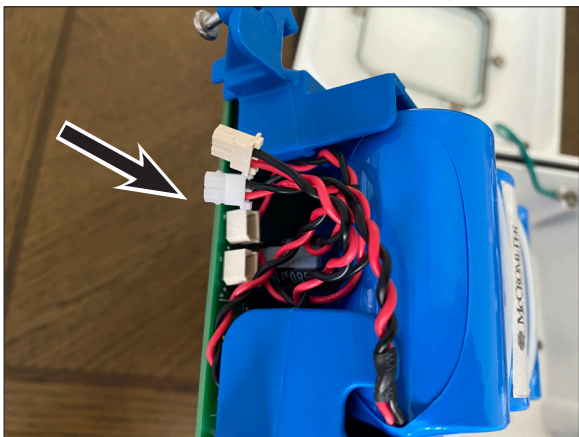

- Cut the two zip ties securing the batteries.

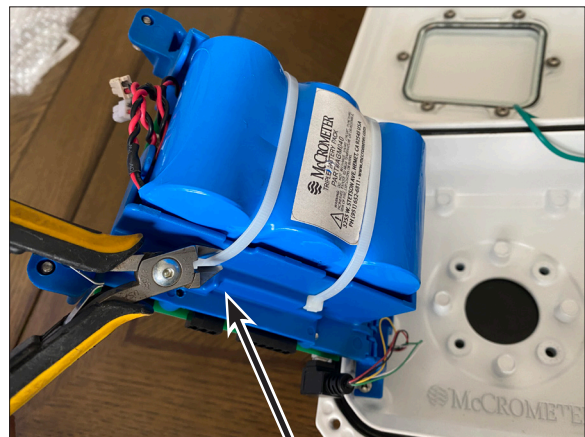

Zip ties

- Remove the large battery pack.



Large battery pack

- Remove the small battery pack located underneath. Pull the wires carefully from underneath the battery tray.



Small battery pack

III. Installing the batteries and restoring the power

9. Cut the zip tie holding the dry pack to the hinge on the converter base.

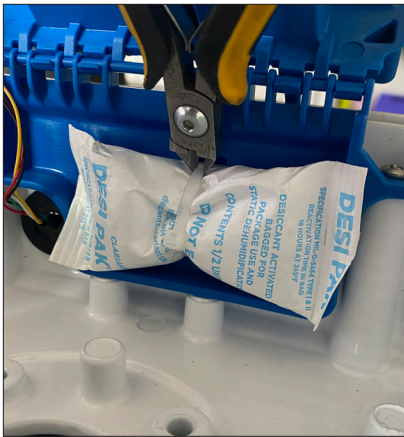

10. Pass the new zip tie through the slots in the internal hinge.

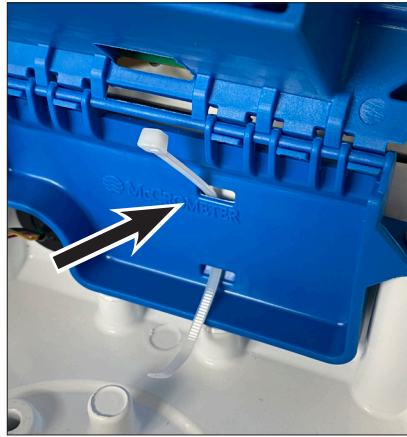

11. Wrap the new zip tie around the new dry pack and cut off the excess.



12. Pass the two large zip ties through the slots in the internal tray holder.

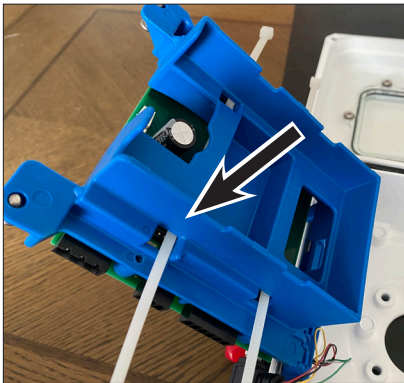

13. Place the small battery pack in the center pocket, making sure the wire leads go out through the opening.



14. Place the large battery pack on the internal tray with wire leads passing through the slot.



15. Secure the battery packs to the internal tray with the two large zip ties. Cut off the excess of each of the zip ties.



16. Plug the batteries into the circuit board.

- The large battery pack goes to connector B1.
- The small battery pack goes to connector B2.

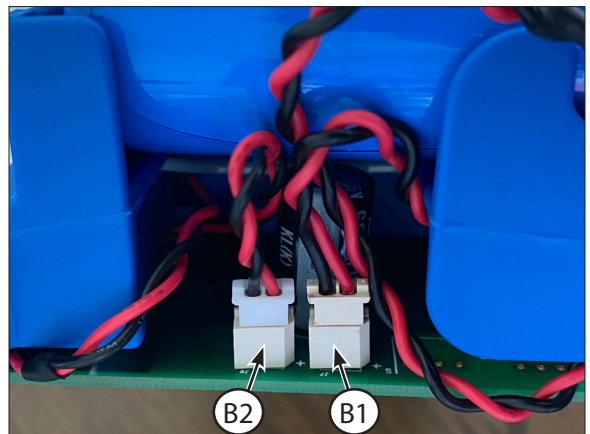

17. Set the hinged LCD/internal battery cover back in place to see the display. The unit will start to power up. Plug in all of the connectors to the board. Ensure that the unit is powered normally and there are no alarms.

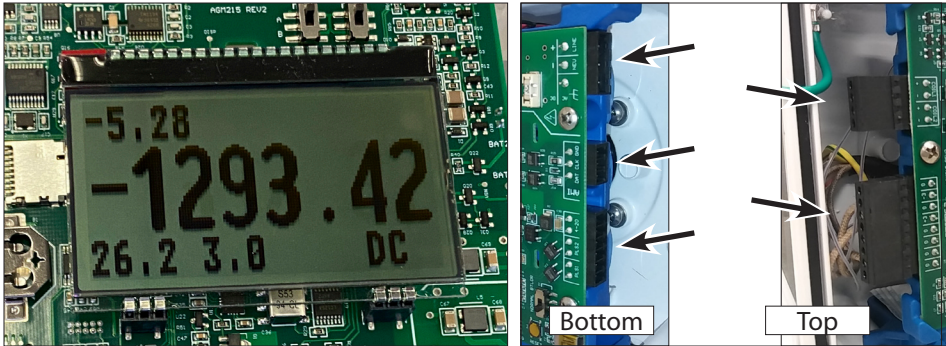

18. Replace the two screws that hold the LCD/battery cover in place.

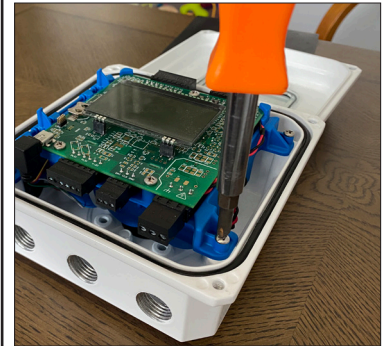

IV. Replacing the gasket

If you installed replacement batteries, we recommend that you replace the gasket.

If you installed new batteries, you must set the gasket in place before replacing the cover and closing up the unit.

19. If your unit has a gasket, remove it.

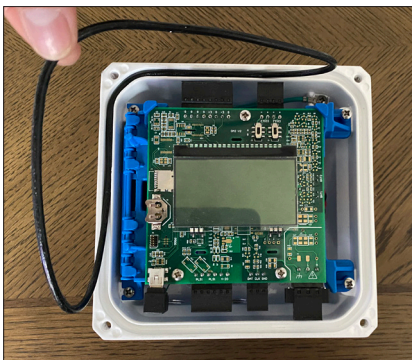

20. Apply a light coating of Molykote to the replacement gasket.

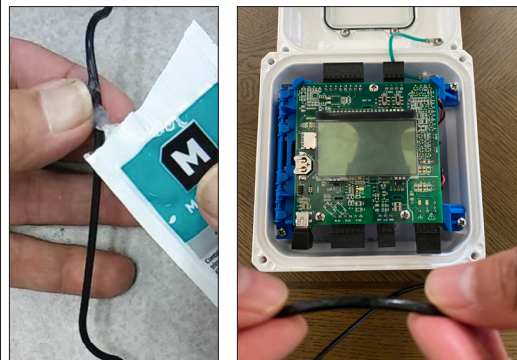

21. Place the gasket in the groove and press it in.



V. Replacing the cover

22. Place the converter lid onto the housing. Tighten the screws firmly. Be careful not to pinch any wires between the lid and the base.



23. Fasten the tamper proof seal as follows:
 a. Guide the wire through the hole in the screw.
 b. Thread the wire through the body of the tamper proof seal.

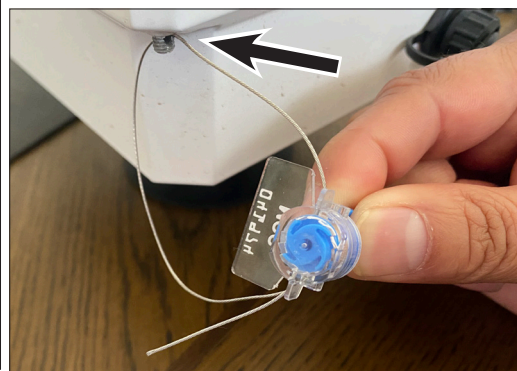

24. Rotate the blue part on the tamper proof seal to bring in the wire and secure the seal close to the screw.

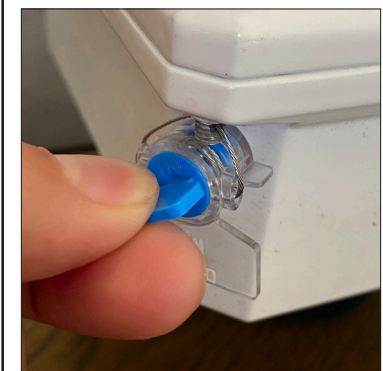

10.0 OPERATION

10.1 General

The flow meter comes pre-configured from the factory based on the installation parameters provided to McCrometer at the time of order. Other than activating the display, there is nothing required of the user for the basic operation of the flow meter.

10.2 Activating the Display

The display is activated when the lid is opened. (Figure 30) The display will remain active for 30 seconds.

The various parts of the interface screen is shown below. (Figure 31) Depending on how the converter is configured with the configuration tool (see section 11.0) the display will show either single direction or bidirectional total flow quantities. Bidirectional flows are represented as either positive (POS) or negative (NEG), as shown at right.



There is an optical sensor embedded in the display located under the McCrometer "swirl" logo at the lower left. If the display does not appear, a flashlight will provide sufficient light to bring it up.



The default setting for the ProComm GO converter is the positive totalizer. This is done so that any negative flow will be set to 0 and not recorded. Bidirectional flow has to be turned on with either negative or net showing for the converter to show a negative flow rate and calculate a negative total.



CAUTION:

If the lid is broken off, contact the Factory for a lid replacement kit. In the meantime, set the lid on the meter in its proper position and use the boot to hold it in place.

The converter display is light activated and requires a minimum amount of light to appear. Environments where light is low, such as in dimly lit buildings or outdoors after sundown may prevent the display from appearing when the lid is raised.



Figure 30. Lift lid to activate display

Default display setting

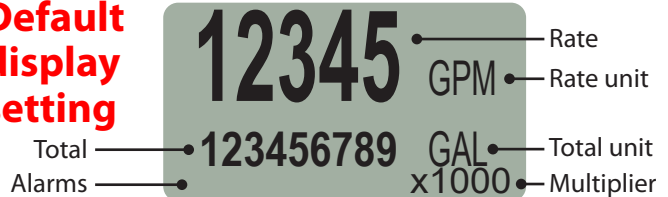

Bidirectional display setting

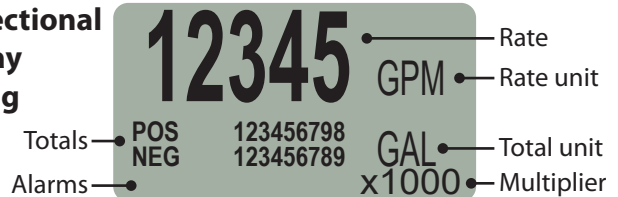

Figure 31. Interface screen, bidirectional and single direction flow

10.3 Converter Boot

The boot simply slips over the electronics enclosure. When installing the boot, insure the corners of the boot fit snugly over the lip of the enclosure. See Figure 32. To remove the boot, grip two corners and pull them away from the lip of the enclosure and then pull upwards. See Figure 33.



It is HIGHLY recommended that converter is covered by the boot at all times when the meter is not being read. The boot adds protection to the converter.

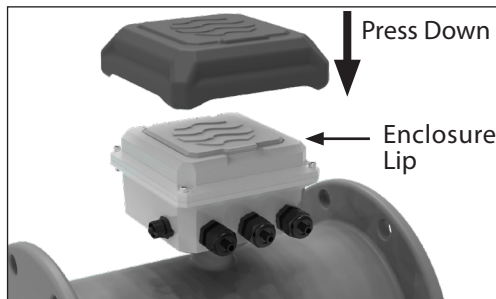

Figure 32. Boot installation

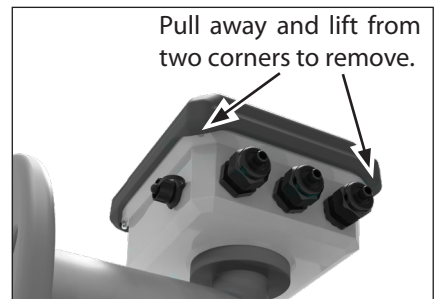

Figure 33. Boot removal

11.0 CONVERTER CONFIGURATION

The converter can be programmed to customize how the data is measured and stored. The configuration tool runs only on Windows 7, 8, or 10 and requires a computer with a USB port.

To access the converter's USB port, unscrew the cap at the left side of the converter. You will need a cable with a mini USB type B connector. (Figure 34)

WARNING
EXPLOSION HAZARD. DO NOT CONNECT/DISCONNECT CONNECTORS OR WIRING OR REMOVE ENCLOSURE LID WHILE WITHIN AN ELECTRICALLY CLASSIFIED HAZARDOUS AREA.

You must have your flow meter's serial number before you begin. There are no installation files. The program and support files can be copied or unzipped into a folder and run from there.

This is only a summary of the configuration tool's functionality. The software has complete set-up and operation instructions included. The software can be downloaded from the McCrometer Web site.

Software Operation

1. Remove the cap that protects the USB port and plug in a mini USB type B cable. (Figure 35) Connect the other end to a laptop computer.
2. Start the software. Follow the instructions shown before setting up your customized configuration. (Figure 36)
3. When you have set up your configuration file, you can change the settings listed below. Using the configuration tool is mostly self-explanatory.
 - Flow rate unit of measure
 - Totalizer unit of measure
 - Multiplier
 - Totalizer presets
 - Forward/reverse pulse enable: 1 pulse per x per unit of measure
 - Pipe ID
 - Clock time and date
 - Pulse output
 - Automated meter reading

When configuration is complete, remove the USB connector and replace the protective cap.



Figure 34. Mini USB type B connector



Figure 35. Plug in mini-USB cable

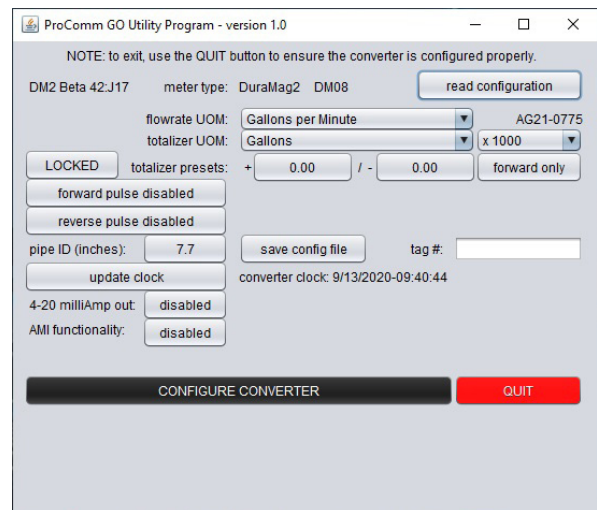
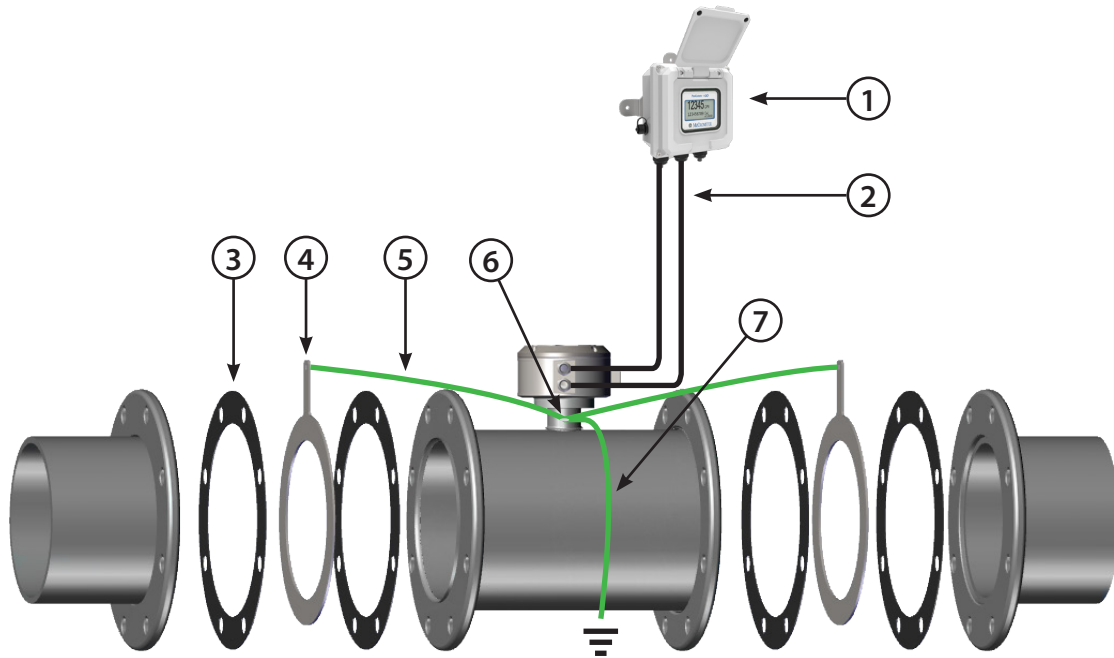

Figure 36. Configuration tool interface

12.0 ERROR MESSAGES FOR TROUBLESHOOTING

DISPLAY MESSAGE	Troubleshooting
BAT LOW	Battery replacement Kit is needed to replace batteries. The batteries Should last approximately 6-9 months from the time the warning is shown.
420 ERR	The 4-20 circuit is not wired correctly. Check the wiring diagram and ensure 9-30VDC power is supplied to the circuit. The output is not source powered.
COIL XCT	There is an issue with the electro magnetic coils. Check that the internal wiring is correct in the converter for the coil wires.
ADC CLIP	The meter signal exceeds the limit of the converter, likely due to noise. Check the meter grounding meets the IOM guidelines and identify any sources of noise.
HIGH HUM	Humidity inside converter housing has exceeded limits. Check for any loose connections on converter housing that could be creating a leak.
COIN LOW	Datalogger time backup battery is low. This is part of the battery replacement kit and should be replaced with the main battery packs.

13.0 REPLACEMENT PARTS

The image above is representative for all Ultra Mag meter models and sizes.

NO.	PART NUMBER	DESCRIPTION
1	PC-RA1	AC Converter (Dual 4-20mA Output)
1	PC-RD1	DC Converter (Dual 4-20mA Output)
1	PC-RA2	AC Converter w/ Modbus RS485 Communications Protocol
1	PC-RD2	DC Converter w/ Modbus RS485 Communications Protocol
2	15035 / 15036	Dual Cables - Submersible
3	1-1557-*	Gaskets (Optional)
4	3-2781-*	Grounding Rings, Stainless Steel (Optional on 4"-12")
5	3-2757-##	Grounding Wire Assembly
6	1-1201-10	Nut, Hex, Brass
7	15029	Earth Ground Wire

* INSERT METER SIZE TO COMPLETE PART NUMBER - INSERT -02 FOR 2", -04 FOR 4", -06 FOR 6", ETC.

-W = 2" - 16" -14 = 14" - 20" -24 = 24" - 30" -36 = 36" - 48"

When ordering replacement parts, please specify: Meter Size • Meter Model • Meter Serial Number

14.0 SPECIFICATIONS

14.1 Flow Meter Specifications

Physical Specifications

Measurement Method	Electromagnetic flow based on Faraday's law
Directionality	Forward and reverse flow indication and forward, reverse, net totalization are standard with all meters
Pipe Sizes	Grooved end: 4-12" ANSI #150: 1.5" to 24" AWWA Class D: 4"-24" ANSI #300: 1.5" to 24"
Body Style	Grooved end: Available as both FM3 and FM5 in sizes 4" - 12" ANSI Flanged: Available as both FM3 and FM5 in sizes 1.5" - 24"
Materials	Carbon steel, stainless steel, epoxy liner
Liner	3M 135 Gray Epoxy (200F)
Electrodes	Type 316 stainless steel, Hastelloy optional
Electrical Connections	<ul style="list-style-type: none"> • Compression gland seals • Quick-Connect
Transmitter	Field Mag 3000: ProComm Go Field Mag 5000: ProComm Max
Transmitter Mount	Either meter mount or remote mount
Sensor Cable Lengths	<ul style="list-style-type: none"> • Standard: 25'/7.6 m McCrometer supplied submersible cable with each remote mount unit. • Optional: Up to 500'/152.4 m, or 25'/7.6 m max for battery powered. • Quick Connect: Available in standard cable lengths: Feet: 25, 50, 75, 100, 125, 150, 175, 200, 500 Meters: 7.6, 15.25, 22.5, 30.5, 38.1, 45.75, 53.3, 61, 152.4 Custom cable lengths at additional cost.

Performance and Operational Specifications

Process Fluid Temperature	-10 to 93°C (14 to 200°F)
Ambient Temperature	-10 to 60°C (14 to 140° F)
IP Rating	<ul style="list-style-type: none"> • Quick Connect (IP67 with remote transmitter) • Compression gland seals (IP67 with remote transmitter)
Sensor Submersibility Depth	With standard strain relief cable: 1.8 m (6 ft.) With optional quick connect cable: 9 m (30 ft.)
Pressure Rating	Grooved End and ANSI #150 (285 psi), ANSI #300 (500 psi), AWWA class D (150 psi)
Velocity Range	0.2 to 32 FPS
Accuracy	<ul style="list-style-type: none"> • FM3: Battery powered: 1% of measured value ± 0.006 ft/s (± 0.0018 m/s) • FM5: Standard: +/- 0.5% of measured value ± 0.006 ft/s (± 0.0018 m/s) Optional: +/- 0.2% of measured value ± 0.006 ft/s (± 0.0018 m/s) <p>IMPORTANT NOTICE ON FLOW METER ACCURACY: The flow meter, the cable and the electronics are factory calibrated for accuracy as a single unit. Changing the cable length with the Splice Kit changes the accuracy of the meter and invalidates the calibration certificate. The Field Mag 5000 flow meter does not have this restriction.</p> <p>Multiple point wet flow calibration of every complete flow tube with its signal transmitter. If desired, the tests can be witnessed by the customer. The McCrometer test facilities are traceable to the National Institute of Standards & Technology. Uncertainty relative to flow is $\pm 0.15\%$.</p>

Flow Meter Specifications (cont.)

Repeatability	±0.05% or ±0.0008ft/s (±0.25mm/s), whichever is greater	
Head Loss	None. No obstruction in line and no moving parts	
Conductivity	5 µs/cm	
Pipe Run Requirements	3000:	1½" to 3" Flanged style meters 0D upstream / 0D downstream
		4" - 24" Steel flanged meters 2D upstream / 1D downstream
	5000:	1½" to 3" Flanged style meters 0D upstream / 0D downstream
		4" - 48" Steel flanged meters 1D upstream / 0D downstream

Other Specifications

Certifications and Approvals	<p>Field Mag 3000</p> <p>Standard model:</p> <ul style="list-style-type: none"> • ISO 9001:2015 certified quality management system • Certified by MET to UL 61010-1 • Certified to NSF / ANSI Standards* <p>HL Model:</p> <ul style="list-style-type: none"> • ISO 9001:2015 certified quality management system • Certified by MET to UL 61010-1 and MET C22.2 No. 61010-1-04 <ul style="list-style-type: none"> • Class I, Division 2, Groups A-D, T4 • Class I, Zone 2, IIC T4 • Certified to NSF / ANSI Standards*
	<p>Field Mag 5000</p> <ul style="list-style-type: none"> • ISO 9001:2015 certified quality management system • Certified to NSF / ANSI Standards*
System Options	<ul style="list-style-type: none"> • Additional sensor cable up to 475' • Stainless steel ID tag
Meter Options and Accessories	<ul style="list-style-type: none"> • DC powered transmitter (10-35 VDC) • Meter mounted transmitter • ANSI flanges • Special lay lengths, including ISO standard lay lengths • Quick connect cable fittings • Transmitter sun shield • Battery or battery-solar powered transmitter (ProComm Go transmitter only)
Output Options	<p>Field Mag 3000</p> <ul style="list-style-type: none"> • 4-20mA • Pulse <p>Field Mag 5000</p> <ul style="list-style-type: none"> • Modbus • 4-20mA • Pulse • Hart
Warranty	<p>Meter: 2 year warranty</p> <p>Liner: Lifetime guarantee</p>

* Certified by IAPMO R&T to NSF/ANSI 61 for material safety and NSF/ANSI 372 for low lead content.

14.2 Flow Meter Dimensions and Weights

1½" to 3" Models

Pipe Size (Nominal)	Flow Ranges (0.2 to 32 FPS) Min-Max GPM	DIMENSIONS (Lay Lengths)								Est. Shipping Weight (lbs.)*	
		A		B	C		D		CL150 ANSI 150#	CL300 ANSI 300#	
		CL150 ANSI 150#	CL300 ANSI 300#		CL150 ANSI 150#	CL300 ANSI 300#	CL150 ANSI 150#	CL300 ANSI 300#			
1 ½"	1.29-200	11	14	4.5	5.0	6.1	6.5	7.25	45	not offered	
2"	1.29-200	11	14	4.5	6.0	6.5	6.5	7.25	45	70	
2 ½"	3.25-510	13.4	15.5	4.5	7.0	7.5	7.0	7.75	50	not offered	
3"	3.25-510	13.4	15.5	4.5	7.5	8.25	7.0	7.75	55	80	

* For remote mount meters, add 4 lbs for ProComm Max transmitter.

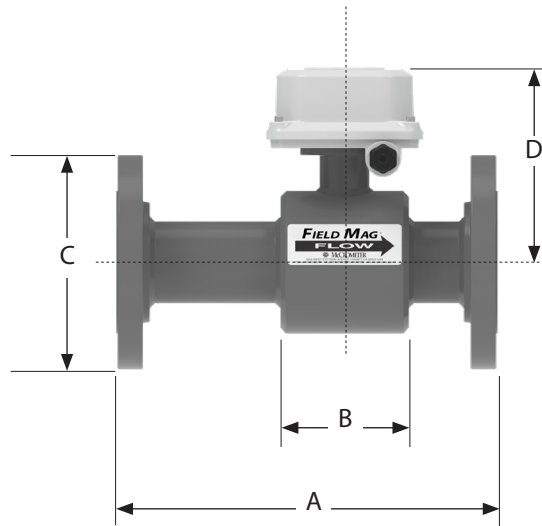

Flow Meter Dimensions and Weights (cont.)

4" to 12" Grooved End Body Style

Pipe Size (Nominal)	Meter Pipe ID	Flow Ranges GPM Min - Max*	Dimensions (Lay Lengths)				Converter Height	Est. Shipping Weight (lbs.)*
			A**	B	C	D	E***	
			Lay Length	Shield Length	Flange OD	Shield OD	FM3 (PCGO)	
4"	4.26	8 - 1,140	16.4	5.625	4.5	6.625	9.2	31
6"	6.357	19 - 2,660	17.6	6.375	6.625	8.625	10.2	49
8"	8.329	33 - 4,870	20.25	7.875	8.625	10.75	11.2	85
10"	10.25	52 - 7,670	24	9.125	10.75	12.75	12.2	133
12"	12.25	74 - 11,180	25.2	9.75	12.75	15	13.4	167

* Flow range is standard minimum 0.2 to maximum 32 fps.

** For remote mount meters, add 4 lbs for ProComm converter.

*** E dimension equals E Base plus converter height. See table below right.

Height to Transmitter Mount	
	D ₁
4"	5.063
6"	6.063
8"	7.125
10"	8.125
12"	9.25

Height: PCGO Transmitter	4.1
Height: ProComm Max Transmitter	6.92

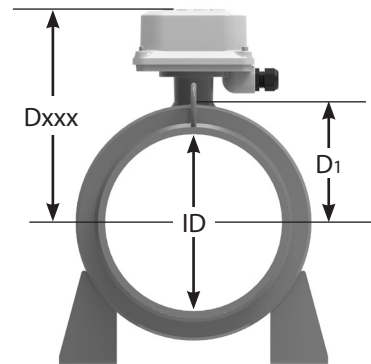
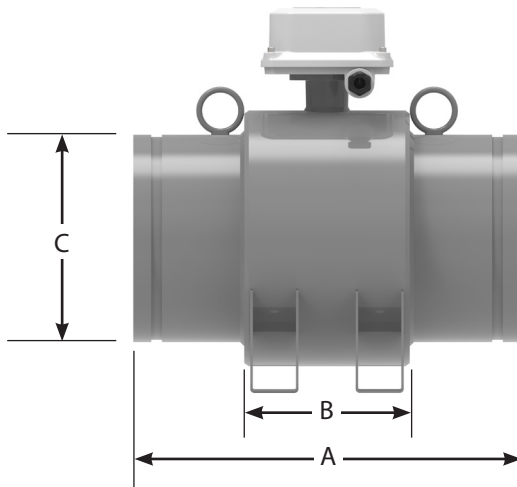

4" to 12" Flanged End Body Style

Pipe Size (Nominal)	Flow Ranges (0.2 to 32 FPS) Min-Max GPM	DIMENSIONS (Lay Lengths)							Transmitter Height		Est. Shipping Weight (lbs.)*		
		A			B	C			Dxxx***				
		AWWA		ANSI	Shield Length	AWWA		ANSI	DFM3 (PCGO)	DFM5 (ProComm Max)	AWWA		ANSI
		150# Class D	150# CL150	300# CL300		150# Class D	150# CL150	300# CL300			150# Class D	150# CL150	300# CL300
4"	6.97-1110	13.4	13.4	13.4	4.125	9.00	9.00	10.00	9.2	12.0	70	108	108
6"	16.1-2560	14.6	14.6	14.6	5.875	11.00	11.00	12.50	10.2	13.0	80	138	138
8"	29.2-4670	16.1	17.25	17.25	6.875	13.50	13.50	15.00	11.2	14.0	115	195	195
10"	46.3-7400	18.5	18.5	18.5	9.125	16.00	16.00	17.50	12.2	15.0	140	247	247
12"	67.3-10760	19.7	19.7	19.7	9.75	19.00	19.00	20.50	13.4	16.2	190	342	342

* Shipping weights are estimated and may change due to specific order packaging.

** For remote mount meters, add 4 lbs for ProComm Max transmitter.

*** DFM3 = D1 + 4.10 (Meter centerline to top of ProComm Go)

DFM5 = D1 + 6.92 (Meter centerline to top of ProComm Max)

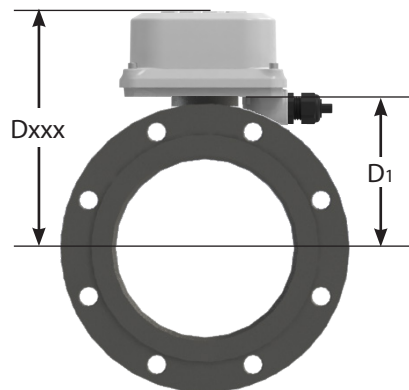
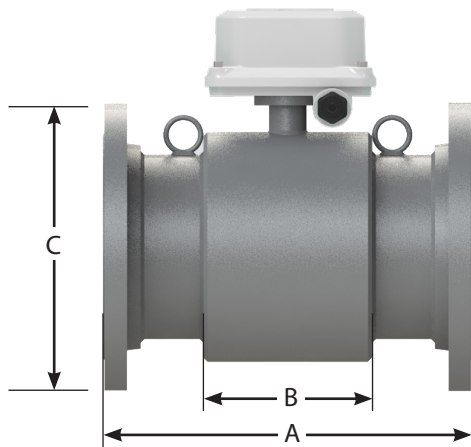

14.3 ProComm GO Converter Specifications

Physical Specifications

Electronic Housing	Diecast aluminum, powder coated enclosure w/ tamper resistant seal, 6½" x 6½" x 43/8" tall
Transmitter Dimensions	See "Dimensions" section for meter mount and remote mount transmitter dimensions.
Power	Battery: Standard: three 3.6V lithium-thionyl chloride (Li-SOCl ₂) D size batteries with two AA backup batteries AC Power: 100-240VAC/45-66Hz (4W) DC Power: Linear power supply 10-35VDC (4 W)
Electrical Connections	<ul style="list-style-type: none"> • Optional shielded cable for 10-32VDC/4-20 mA output • Optional shielded cable for pulse out

Performance and Operational Specifications

Battery Life	Five-year expected battery life, five-year battery warranty
Location	Indoor or outdoor use
Altitude	Operating: 2000 meters Storage: 12,000 meters
Operating Temperature	-4° to 140° F (-20° to 60° C)
Storage Temperature	-4° to 140° F (-20° to 60° C)
Relative Humidity	0% to 100%
IP Rating	IP67 Die cast aluminum transmitter
Outputs	Digital output: Digital pulse (open collector) output for volumetric - Two isolated digital pulse (open collector) outputs for volumetric - AMI output Analog output: 4-20mA: Galvanically Isolated, 16 Bit resolution. All power configurations (including battery). Note: 9-30 VDC loop power required (not supplied via transmitter)

Display and Measurement

Display	<ul style="list-style-type: none"> • 2-Line LCD display (no backlight) • Non-volatile memory • Anti-reverse totalizer (standard) • Total (to 9 digits of precision) 	<ul style="list-style-type: none"> • Flow rate and velocity (to 5 digits of precision) • Two alarms: low battery and empty pipe (optional) • Opening lid activates display
Digits	5 Rate, 9 Total	
Units	GPM Gallons per minute IGM Imperial gal per minute CFM Cubic feet per minute MGD Mega gal per day MI9 Miners inch (9G) B5M Barrels per minute (55G) CFS Cubic feet per second MI1 Miners inch (11.22G) B5H Barrels per hour (55G) MLD Megaliters per day APD Acre feet per day B5D Barrels per day (55G) LPS Liters per second KLH Kiloliters per hour B4M Barrels per minute (42G) CMH Cubic meters per hour LPH Liters per hour B4H Barrels per hour (42G) LPM Liters per minute CMM Cubic meters per minute B4D Barrels per day (42G) GPH Gallons per hour CFM Cubic feet per minute	



Display and Measurement (cont.)

Totalizer Units	GAL	Gallons	B42	Barrel (42G)	MH1	Miners Inch Hour (11.22G)
	CUF	Cubic Feet	B46	Barrel (46G)	MD1	Miners Inch Day (11.22G)
	AFT	Acre Feet	B55	Barrel (55G)	MH9	Miners Inch Hour (9G)
	CUM	Cubic Meters	IMG	Imperial Gallon	MD9	Miners Inch Day (9G)
	LIT	Liters	AIN	Acre Inch	KGL	Kilo Gallons
	MML	Megaliter	TON	Ton (Short)	MGL	Mega Gallons
	MTT	Metric Ton (KL)	MM1	Miners Inch Minute (11.22G)	IN3	Cubic Inch
	B31	Barrel (31G)	MM9	Miners Inch Minute (9G)		
	Data Logger	Standard with all models, minimum of five years of data stored				

Other Specifications

Options and Accessories	<ul style="list-style-type: none"> • Data Logger - included as standard with five years of data storage at default (12hr) interval. (Cable sold separately) • AC, DC, and battery powered with battery backup powered available
Safety	<ul style="list-style-type: none"> • IEC 61010-1, Pollution Degree II • Overvoltage protection Category III

Certifications

Standard Model	<ul style="list-style-type: none"> • ISO 9001:2015 certified quality management system • CE • Certified by MET to UL 61010-1 	  
HL Model	<ul style="list-style-type: none"> • ISO 9001:2015 certified quality management system • CE • Certified by MET to UL 61010-1 and MET C22.2 No. 61010-1-04 <ul style="list-style-type: none"> • Class I, Division 2, Groups A B C D, T4 • Class I, Zone 2, IIC T4 <p><i>Note: ProComm GO with SmartTrax On Board is not available for hazardous locations.</i></p>	

14.4 ProComm GO Converter Dimensions

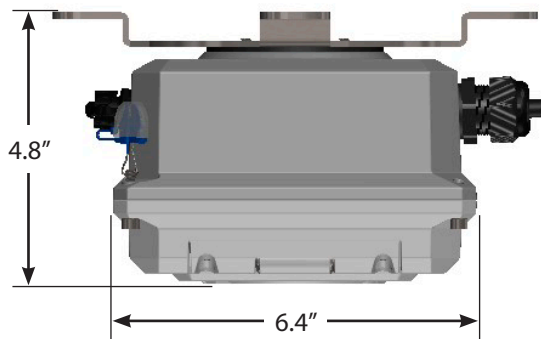
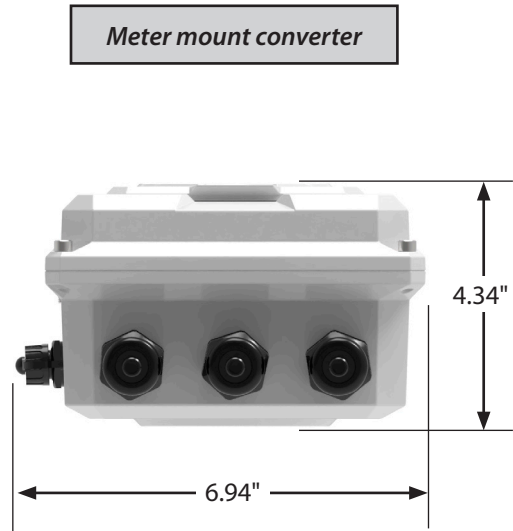
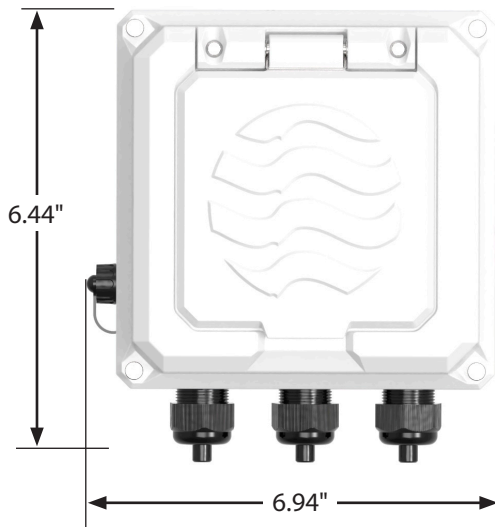

Remote mount converter

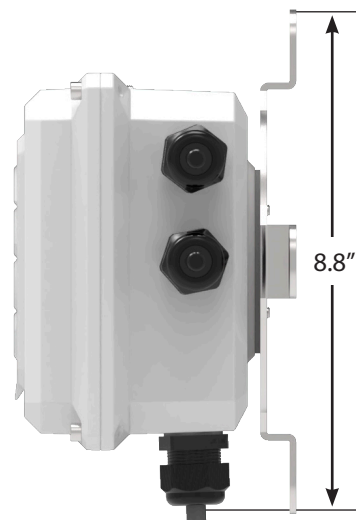
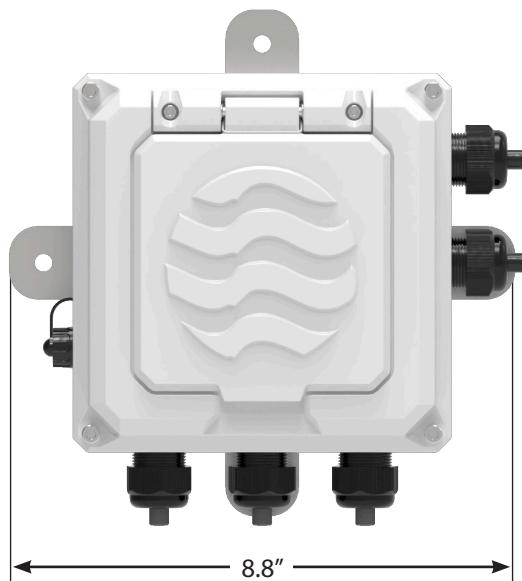

15.0 RETURNING A UNIT FOR REPAIR

If the unit needs to be returned to the factory for repair, please do the following:

- Prior to calling for a return authorization number, determine the model number, serial number, and reason for return.
- Contact McCrometer Customer Service Department and ask for a Return Authorization (RA) number.
 - Telephone: 1-800-220-2279
 - Email: customerservice@mccrometer.com
- Ship the meter in the original packaging, if possible. Do not ship manuals, power cords, or other parts with your unit unless required for repair.
- Please make sure the meter is clean and free from foreign debris prior to shipping. McCrometer may charge a cleaning fee if the meter is sent without being cleaned.
- Write the RA number on the outside of the shipping box. All return shipments should be insured.
- Address all shipments to:

McCrometer, Inc.
RMA #
3255 W. Stetson Avenue
Hemet, CA 92545

WARRANTY

This Warranty shall apply to and be limited to the original purchaser consumer of any McCrometer product. Meters or instruments defective because of faulty material or workmanship will be repaired or replaced, at the option of McCrometer, free of charge, FOB the factory in Hemet, California, within a period of two (2) years from the date of delivery.

Repairs or modifications by others than McCrometer or their authorized representatives shall render this Warranty null and void in the event that factory examination reveals that such repair or modification was detrimental to the meter or instrument. Any deviations from the factory calibration require notification in writing to McCrometer of such recalibrations or this Warranty shall be voided.

In case of a claim under this Warranty, the claimant is instructed to contact McCrometer Inc., Attn: Technical Support, 3255 W. Stetson Ave., Hemet, California 92545, and to provide an identification or description of the meter or instrument, the date of delivery, and the nature of the problem.

The Warranty provided above is the only Warranty made by McCrometer with respect to its products or any parts thereof and is made expressly in lieu of any other warranties, by course of dealing, usages of trade or otherwise, expressed or implied, including but not limited to any implied warranties of fitness for any particular purpose or of merchantability under the uniform commercial code. It is agreed this Warranty is in lieu of and buyer hereby waives all other warranties, guarantees or liabilities arising by law or otherwise. Seller shall not incur any other obligations or liabilities or be liable to buyer, or any customer of buyer for any anticipated or lost profits, incidental or consequential damages, or any other losses or expenses incurred by reason of the purchase, installation, repair, use or misuse by buyer or third parties of its products (including any parts repaired or replaced); and seller does not authorize any person to assume for seller any other liability in connection with the products or parts thereof. This Warranty cannot be extended, altered or varied except by a written instrument signed by seller and buyer.

This Warranty gives you specific legal rights, and you may also have other rights which vary from state to state.

McCrometer reserves the right to make improvements and repairs on product components which are beyond the Warranty period at the manufacturer's option and expense, without obligation to renew the expired Warranty on the components or on the entire unit. Due to the rapid advancement of meter design technology, McCrometer reserves the right to make improvements in design and material without prior notice to the trade.

All sales and all agreements in relation to sales shall be deemed made at the manufacturer's place of business in Hemet, California and any dispute arising from any sale or agreement shall be interpreted under the laws of the State of California.