

Applies to the following models:

Field Mag 3000

Field Mag 5000

The Field Mag 3000 utilizes our ProComm Go electronics which allows AC or DC power with battery backup or straight battery operation with pulse and 4-20mA outputs with an accuracy of +/- 1.0% of reading.

The Field Mag 5000 utilizes our ProComm Max electronics which allows AC or DC power with Modbus, pulse and 4-20mA outputs with an accuracy of +/- 0.5% of reading.

Applications	
<p>These Field Mag models are specifically designed for Water Transfer, Produced Water, and Mining operations where rugged and quick connections are needed with the added benefit of higher temperature ratings and exotic electrode materials. Our epoxy liner ensures long life even in slurry applications.</p>	
<ul style="list-style-type: none"> Well transfers Pond transfers Produced Water Blending Applications Water Treatment Biocide skids 	<ul style="list-style-type: none"> Dewatering Slurries Tailings Effluent Raw Water Surface Water

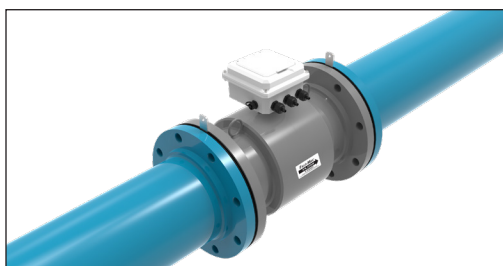
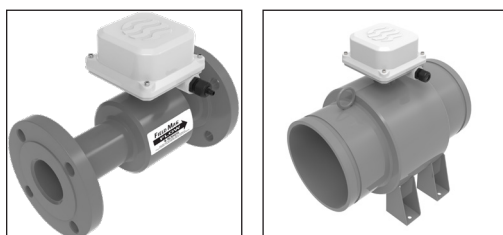

Performance Advantages

Field Mag 3000 and 5000 are flow measurement products curated to the mining and water transfer industries. Offered with the ever-popular grooved end fittings and fixed feet for stability and mounting applications, the Field Mag series eliminates the hassle of traditional full-bore mag meter installation and transportation. The Field Mag series features McCrometer's proprietary fusion-bonded epoxy rather than a rubber or plastic liner, guaranteed against tearing and delamination for the lifetime of the meter. This durable, highly rugged flow instrument gives operators and technicians peace of mind that their metering investment will withstand harsh environments and a multitude of flow applications.

Advantages of Using Grooved End Connections Versus Flanges

Ideal for water transfer, produced water and mining applications, grooved end connections provide greater ease and speed of installation, lower installation costs, and less down time during installation. The decrease in weight recognized by the removal of two sets of flanges and grooved end adapters is revolutionary.

Differences Between the Field Mag 3000 and Field Mag 5000

	Field Mag 3000	Field Mag 5000
Transmitter	ProComm GO	ProComm Max
Coating	3M 135 Gray Epoxy (200F)	
Sizes	Grooved end: 4" to 12" ANSI #150 1.5" to 24" AWWA Class D 4" to 24" ANSI #300 1.5" to 24"	
End connections	Grooved end (285 PSI), ANSI #150 (285 PSI), ANSI #300 (500 PSI), AWWA Class D (150 PSI)	
Transmitter power	Battery, AC/DC with battery backup	AC / DC
Electrodes	SS or Hastelloy Electrodes	
Hazardous location	Class I, Division 2	
Outputs	4-20mA, pulse	Modbus, 4-20mA, pulse, Hart

Signal Transmitters

The signal transmitter allows the measurements, functional programming, and data reporting to be communicated through the display and outputs. There are two different transmitter models used in various applications. Both transmitters are available as either meter mount or remote mount.

• ProComm GO Transmitter

The Field Mag 3000 flow meter is accompanied by the ProComm GO electronics and is battery powered, ideal for remote installations and locations with unreliable power sources.

- Output options include pulse and 4-20mA
- Datalogger
- Optional Class 1 Div 2
- Battery powered with optional AC/DC with battery backup
- Offering $\pm 1\%$ accuracy
- DIY battery replacement and in-field transmitter programming available via USB cable and laptop
- CRN (ANSI), CE, UL certifications

• ProComm Max Transmitter

The Field Mag 5000 is offered with the ProComm Max electronics, offering greater accuracy and more sophisticated output options for users needing superior system integration and data collection.

- Output options include Hart, ModBus, 4-20mA, pulse
- Datalogger and optional AMI/AMR
- Optional Class 1 Div 2
- AC/DC powered
- $\pm 0.5\%$ standard accuracy
- Bi-directional flow available
- CRN (ANSI), CE, UL, CSA certifications

Quality Manufacturing

Field Mag flow meters are manufactured to the highest standard available for mag meters. The grooved end connection design permits use in a wide range of applications while maintaining a full ANSI #150 pressure rating of 285 PSI. The fabricated tube is stainless steel with either ANSI flanged or grooved end connections and is lined with an NSF approved, fusion bonded epoxy material.

Installation

Field Mag flow meter installation is similar to placing a short length of flanged or grooved end pipe in the line since there is no protrusion or restriction within the sensor. The meter can be installed vertically flowing up, horizontally, or inclined flowing up on either the suction or discharge lines.

Electromagnetic flow meters cannot normally be installed on the suction side of the pump due to potential issues regarding the liner. Since the Field Mag utilizes the Fusion Bonded Epoxy Ultraliner, there is no risk of delamination experienced by other flow meters.

The meter must have a full pipe of liquid for proper operation. Fluid must be grounded to the downstream flange of the sensor via internal grounding electrodes.

The meter needs to be located a minimum distance before and after flow disturbances, such as elbows, pumps, partially opened valves, and changes in pipe diameter. The uneven flow created by these obstructions can vary with each system.

The minimum distance is measured in pipe diameters (D). To ensure accuracy locate the sensor upstream and downstream of flow disturbances as follows:

3000:	1½" to 3" 4" - 24"	0D upstream / 0D downstream 2D upstream / 1D downstream
5000:	1½" to 3" 4" - 24"	0D upstream / 0D downstream 1D upstream / 0D downstream

All blending and chemical injection should be done early enough so the flow media is thoroughly mixed prior to entering the measurement area.

Field Mag Flow Meter Specifications

All specifications apply to both Field Mag 3000 and Field Mag 5000 models except where noted.

Physical Specifications

Measurement Method	Electromagnetic flow based on Faraday's law
Directionality	Forward and reverse flow indication and forward, reverse, net totalization are standard with all meters
Pipe Sizes	Grooved end: 4-12" ANSI #150: 1.5" to 24" AWWA Class D: 4"-24" ANSI #300: 1.5" to 24"
Body Style	Grooved end: Available as both FM3 and FM5 in sizes 4" - 12" ANSI Flanged: Available as both FM3 and FM5 in sizes 1.5" - 24"
Materials	Carbon steel, stainless steel, epoxy liner
Liner	3M 135 Gray Epoxy (200F)
Electrodes	Type 316 stainless steel, Hastelloy optional
Electrical Connections	<ul style="list-style-type: none"> • Compression gland seals • Quick-Connect
Transmitter	Field Mag 3000: ProComm Go Field Mag 5000: ProComm Max
Transmitter Mount	Either meter mount or remote mount
Sensor Cable Lengths	<ul style="list-style-type: none"> • Standard: 25'/7.6 m McCrometer supplied submersible cable with each remote mount unit. • Optional: Up to 500'/152.4 m, or 25'/7.6 m max for battery powered. • Quick Connect: Available in standard cable lengths: Feet: 25, 50, 75, 100, 125, 150, 175, 200, 500 Meters: 7.6, 15.25, 22.5, 30.5, 38.1, 45.75, 53.3, 61, 152.4 Custom cable lengths at additional cost.

Performance and Operational Specifications

Operating Temperature	-10 to 93°C (14 to 200°F)
Storage Temperature	-15 to 93°C (5 to 200° F)
IP Rating	<ul style="list-style-type: none"> • Quick Connect (IP67 with remote transmitter) • Compression gland seals (IP67 with remote transmitter)
Sensor Submersibility Depth	With standard strain relief cable: 1.8 m (6 ft.) With optional quick connect cable: 9 m (30 ft.)
Pressure Rating	Grooved End and ANSI #150 (285 psi), ANSI #300 (500 psi), AWWA class D (150 psi)
Velocity Range	0.2 to 32 FPS
Accuracy	<ul style="list-style-type: none"> • FM3: Battery powered: 1% of measured value ± 0.006 ft/s (± 0.0018 m/s) • FM5: Standard: $\pm 0.5\%$ of measured value ± 0.006 ft/s (± 0.0018 m/s) Optional: $\pm 0.2\%$ of measured value ± 0.006 ft/s (± 0.0018 m/s) <p>IMPORTANT NOTICE ON FLOW METER ACCURACY: The flow meter, the cable and the electronics are factory calibrated for accuracy as a single unit. Changing the cable length with the Splice Kit changes the accuracy of the meter and invalidates the calibration certificate. The Field Mag 5000 flow meter does not have this restriction.</p> <p>Multiple point wet flow calibration of every complete flow tube with its signal transmitter. If desired, the tests can be witnessed by the customer. The McCrometer test facilities are traceable to the National Institute of Standards & Technology. Uncertainty relative to flow is $\pm 0.15\%$.</p>

Field Mag Flow Meter Specifications (cont.)

Repeatability	±0.05% or ±.0008ft/s (±0.25mm/s), whichever is greater	
Head Loss	None. No obstruction in line and no moving parts	
Conductivity	5 µs/cm	
Pipe Run Requirements	3000:	1½" to 3" Flanged style meters 0D upstream / 0D downstream
		4" - 24" Steel flanged meters 2D upstream / 1D downstream
	5000:	1½" to 3" Flanged style meters 0D upstream / 0D downstream
		4" - 48" Steel flanged meters 1D upstream / 0D downstream

Other Specifications

Certifications and Approvals	<p>Field Mag 3000</p> <p>Standard model:</p> <ul style="list-style-type: none"> ISO 9001:2015 certified quality management system Certified by MET to UL 61010-1 Certified to NSF / ANSI Standards* <p>HL Model:</p> <ul style="list-style-type: none"> ISO 9001:2015 certified quality management system Certified by MET to UL 61010-1 and MET C22.2 No. 61010-1-04 <ul style="list-style-type: none"> Class I, Division 2, Groups A-D, T4 Class I, Zone 2, IIC T4 Certified to NSF / ANSI Standards* 	
	<p>Field Mag 5000</p> <ul style="list-style-type: none"> ISO 9001:2015 certified quality management system Certified to NSF / ANSI Standards* 	
System Options	<ul style="list-style-type: none"> Additional sensor cable up to 475' Stainless steel ID tag 	
Meter Options and Accessories	<ul style="list-style-type: none"> DC powered transmitter (10-35 VDC) Meter mounted transmitter ANSI flanges Special lay lengths, including ISO standard lay lengths Quick connect cable fittings Transmitter sun shield Battery or battery-solar powered transmitter (ProComm Go transmitter only) 	
Output Options	<p>Field Mag 3000</p> <ul style="list-style-type: none"> 4-20mA Pulse <p>Field Mag 5000</p> <ul style="list-style-type: none"> Modbus 4-20mA Pulse Hart 	
Warranty	<p>Meter: 2 year warranty</p> <p>Liner: Lifetime guarantee</p>	

* Certified by IAPMO R&T to NSF/ANSI 61 for material safety and NSF/ANSI 372 for low lead content.

Flow Meter Dimensions and Weights

1½" to 3" Models

Pipe Size (Nominal)	Flow Ranges (0.2 to 32 FPS) Min-Max GPM	DIMENSIONS (Lay Lengths)						Est. Shipping Weight (lbs.)*		
		A		B	C		D		CL150 ANSI 150#	CL300 ANSI 300#
		CL150 ANSI 150#	CL300 ANSI 300#		CL150 ANSI 150#	CL300 ANSI 300#	CL150 ANSI 150#	CL300 ANSI 300#		
1 ½"	1.29-200	11	14	4.5	5.0	6.1	6.5	7.25	45	not offered
2"	1.29-200	11	14	4.5	6.0	6.5	6.5	7.25	45	70
2 ½"	3.25-510	13.4	15.5	4.5	7.0	7.5	7.0	7.75	50	not offered
3"	3.25-510	13.4	15.5	4.5	7.5	8.25	7.0	7.75	55	80

* For remote mount meters, add 4 lbs for ProComm Max transmitter.

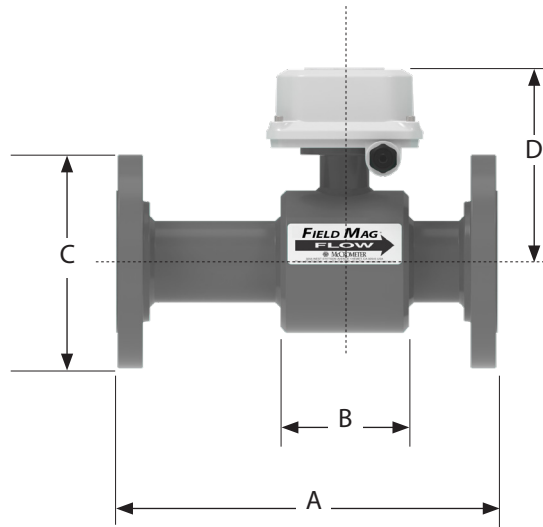

Dimensions and Weights (cont.)

4" to 12" Grooved End Body Style

Pipe Size (Nominal)	Meter Pipe ID	Flow Ranges GPM Min - Max*	Dimensions (Lay Lengths)			Transmitter Height		Est. Shipping Weight (lbs.)*
			A**	B	C	Dxxx***		
			Lay Length	Shield Length	Pipe OD	DFM3 (PCGO)	DFM5 (ProComm Max)	
4"	4.03	8 - 1,140	13.4	4.125	4.5	9.2	12.0	31
6"	6.07	19 - 2,660	14.6	5.875	6.625	10.2	13.0	49
8"	8.18	33 - 4,870	16.1	6.875	8.625	11.2	14.0	85
10"	10.02	52 - 7,670	18.5	9.125	10.75	12.2	15.0	133
12"	12.00	74 - 11,180	19.7	9.75	12.75	13.4	16.2	167

* Flow range is standard minimum 0.2 to maximum 32 fps.

** For remote mount meters, add 4 lbs for ProComm Max transmitter.

*** DFM3 = D1 + 4.10 (Meter centerline to top of ProComm Go)

DFM5 = D1 + 6.92 (Meter centerline to top of ProComm Max)

Height to Transmitter Mount	
	D1
4"	5.063
6"	6.063
8"	7.125
10"	8.125
12"	9.25

Height: PCGO Transmitter	4.1
Height: ProComm Max Transmitter	6.92

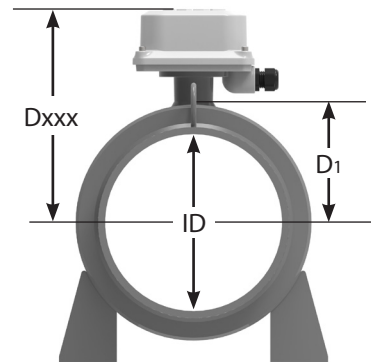
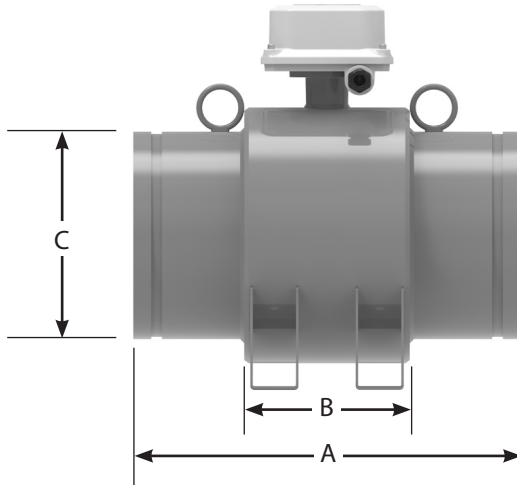

Dimensions and Weights (cont.)

4" to 12" Flanged End Body Style

Pipe Size (Nominal)	Flow Ranges (0.2 to 32 FPS) Min-Max GPM	DIMENSIONS (Lay Lengths)							Transmitter Height		Est. Shipping Weight (lbs.)*		
		A			B	C			Dxxx***				
		AWWA		ANSI	Shield Length	AWWA		ANSI	DFM3 (PCGO)	DFM5 (ProComm Max)	AWWA		ANSI
		150# Class D	150# CL150	300# CL300		150# Class D	150# CL150	300# CL300			150# Class D	150# CL150	300# CL300
4"	6.97-1110	13.4	13.4	13.4	4.125	9.00	9.00	10.00	9.2	12.0	70	108	108
6"	16.1-2560	14.6	14.6	14.6	5.875	11.00	11.00	12.50	10.2	13.0	80	138	138
8"	29.2-4670	16.1	17.25	17.25	6.875	13.50	13.50	15.00	11.2	14.0	115	195	195
10"	46.3-7400	18.5	18.5	18.5	9.125	16.00	16.00	17.50	12.2	15.0	140	247	247
12"	67.3-10760	19.7	19.7	19.7	9.75	19.00	19.00	20.50	13.4	16.2	190	342	342

* Shipping weights are estimated and may change due to specific order packaging.

** For remote mount meters, add 4 lbs for ProComm Max transmitter.

*** DFM3 = D1 + 4.10 (Meter centerline to top of ProComm Go)

DFM5 = D1 + 6.92 (Meter centerline to top of ProComm Max)

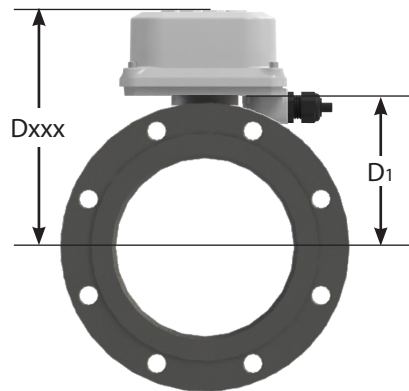
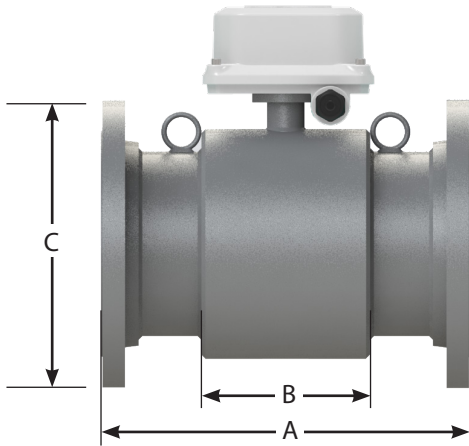

Dimensions and Weights (cont.)

14+\" Flanged End Body Style

Pipe Size (nom.)	Flow Ranges (0.2 to 32 FPS) Min-Max GPM	DIMENSIONS										Est. Shipping Weight (lbs.)*			
		A				B	C				D**				
		AWWA		ANSI			AWWA		ANSI			AWWA		ANSI	
		150# Class D	300# Class F	150# CL150	300# CL300		150# Class D	300# Class F	150# CL150	300# CL300		150# Class D	300# Class F	150# CL150	300# CL300
14"	90.1-14410	21.70	22.75	22.75	22.75	10.375	21.00	23.00	21.00	23.00	13.56	Contact factory			
16"	117-18670	23.60	25.25	25.25	25.25	12.375	23.50	25.50	23.50	25.50	14.31				
18"	149-23820	23.60	25.25	25.25	25.25	12.375	25.00	28.00	25.00	28.00	15.31				
20"	186-29600	25.60	28.25	28.25	28.25	14.375	27.50	30.50	27.50	30.50	16.25				
24"	269-43040	30.70	35.75	35.75	35.75	18.875	32.00	36.00	32.00	36.00	18.25				

*Shipping weights are estimated and may change due to specific order packaging

** DIM D represents the remote transmitter height in relation to the meter centerline.

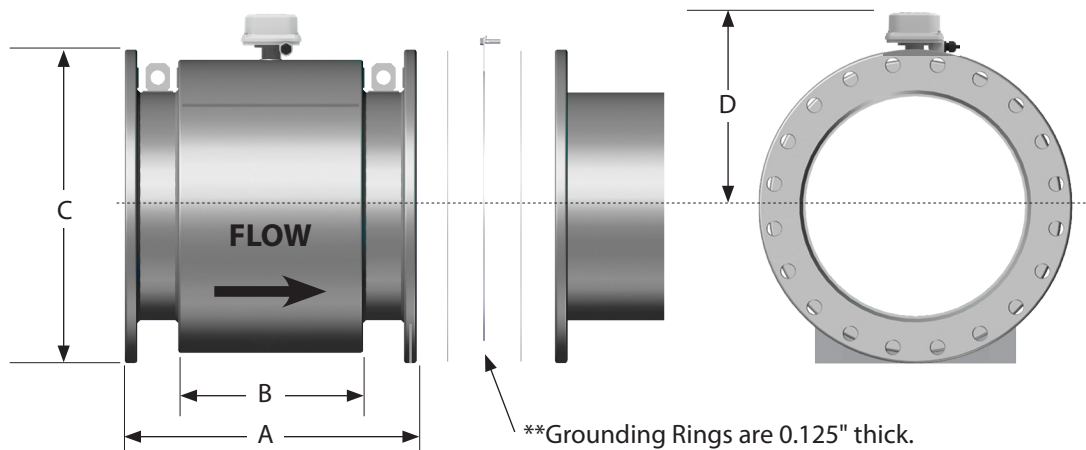

Meter Grounding Recommendations

Grounding the meter body for safety according to national (NEC) or local electrical codes is recommended on ALL meter installations.

All Field Mag flow meter installations require minimum grounding with a 12-gauge ground wire to an earth ground.

Flanged end meters

When installing into a PVC or plastic pipe system, grounding rings for flanged meters are recommended for all sizes. Flanges on the Field Mag sensor have a non-conductive coating and may not require grounding rings. For best performance, McCrometer provides grounding rings for all sizes.

For best performance, grounding the fluid column is recommended when the meter is installed in an electrically noisy environment, such as with VFD pumps or nearby electrical systems with insufficient grounding.

Grooved end meters

Grooved end meters do not require grounding rings and only require a ground wire connecting the ground lug to a ground.

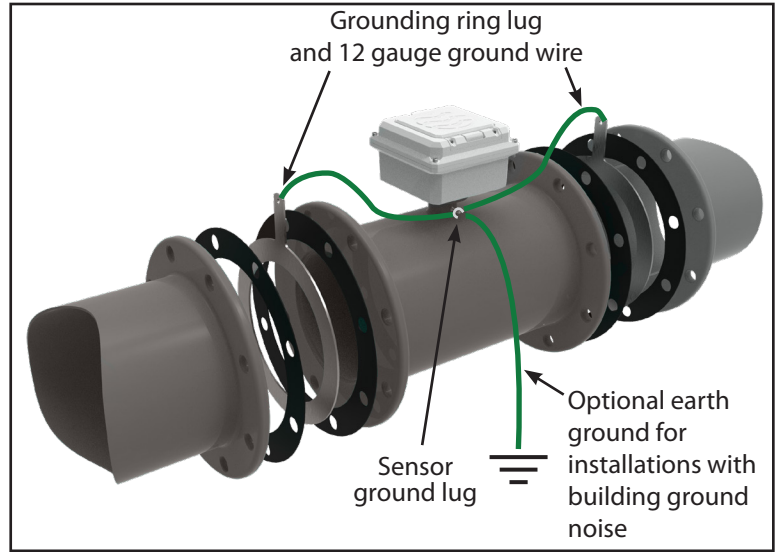
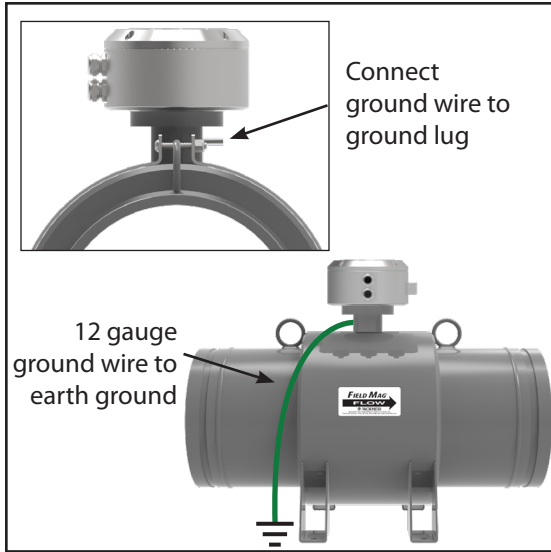

Recommended method of grounding

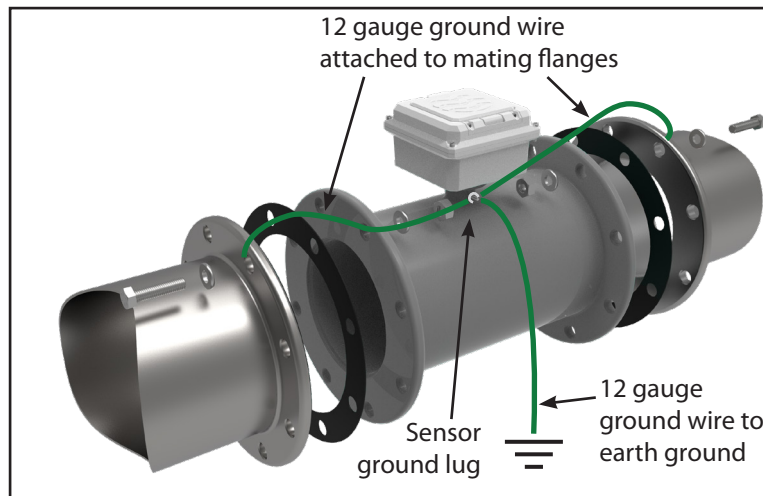

**Alternative method of grounding with
conductive or uncoated pipe**

Field Mag FM3 Part Number Matrix

FM3		-								-		-		-		-	
Nominal Line Size																	
1.5"	0C																
2"	02																
2.5"	0D																
3"	03																
4"	04																
6"	06																
8"	08																
10"	10																
12"	12																
14"	14																
16"	16																
18"	18																
20"	20																
24"	24																
Flange Connections																	
Victaulic Grooved Ends (285 psi Rating)		V															
AWWA Class D (150 psi Rating)		1															
ANSI Class 150# (285 psi Rating)		2															
ANSI Class 300# (500 psi Rating)		3															
Electrode Material Options																	
S316 Stainless Steel (Standard)		S															
Hastelloy		H															
Converter Mounting and Cable Connector Options																	
Meter Mount Converter		M															
IP68 Strain Relief [Remote Mount] (Standard)		R															
IP68 Quick Connect Potted Connector [Remote Mount]		Q															
Converter Power Options																	
Battery Power (Standard)		B															
Solar Power, Battery Backup		S															
A/C Power, Battery Backup		E															
DC Power, Battery Backup		F															
Converter Output Options																	
No Outputs (Standard)																	
No Outputs, DC cable only		0															
Two Digital Out		1															
4-20mA Analog only		2															
4-20mA Analog + Two Dig Out		3															
DC Power/ Analog Out Cable Options																	
No DC Power or Outputs (Standard)																	
No Cable - Output Configured (Quick Conn)		0															
6 ft (Open Leads)		1															
25 ft (Open Leads)		2															
50 ft (Open Leads)		3															

continued on next page

Field Mag FM3 Part Number Matrix (cont.)

FM3	-		-		-		-		-	
Pulse Cable Length Options										
No Outputs (Standard)										
No Cable - Output Configured (Quick Conn)	0									
6 ft (Open Leads)	1									
25 ft (Open Leads)	2									
50 ft (Open Leads)	3									
Output Cable Terminal Options										
Strain Relief	1									
Quick Connect Cable Terminals	2									
SmartTrax Options										
No SmartTrax Options										
Sensus Protocol (6ft cable, Nicor Connector hardwired only)	SEN									
Itron 6 digit Protocol (6ft cable, Nicor Connector hardwired only)	IT6									
Itron 9 digit [100W] Protocol (6ft cable, Nicor Connector hardwired only)	IT9									
Neptune Protocol (6ft cable, Nicor Connector hardwired only)	NEP									
2 ft SmartTrax Standalone Unit ExactRead Cable (Strain Relief Only)	S02									
6 ft SmartTrax Standalone Unit ExactRead Cable (Strain Relief Only)	S06									
25 ft SmartTrax Standalone Unit ExactRead Cable (Strain Relief Only)	S25									
50 ft SmartTrax Standalone Unit ExactRead Cable (Strain Relief Only)	S50									
Non Standard Length Options										
McCrometer Length (Standard)										
Custom Specified Length (Nominal Length)	L22									
No Batteries, Battery Tray Options										
Includes Batteries (Standard)										
No Batteries (Alkaline Tray)	NBA									
No Batteries (Lithium Tray)	NBL									
Canadian Registration Certified										
No CRN Needed										
CRN Certified (Sizes 4-12" ANSI Flanges Only)	CRN									
Hazardous Area Location										
No Hazardous Location Needed										
Class 1, Division 2, Groups A-D, T5	HL									

Field Mag FM5 Part Number Matrix

FM5		-	-	-	-	-	-	-	-	-	-	-	-	-	-
Nominal Line Size															
1.5"	0C														
2"	02														
2.5"	0D														
3"	03														
4"	04														
6"	06														
8"	08														
10"	10														
12"	12														
14"	14														
16"	16														
18"	18														
20"	20														
24"	24														
End Connection Options															
Victaulic Grooved Ends (285 psi Rating)		V													
AWWA Class D (150 psi Rating)		1													
ANSI Class 150# (285 psi Rating)		2													
ANSI Class 300# (300 psi Rating)		3													
Electrode Material Options															
S316 Stainless Steel (Standard)		S													
Hastelloy		H													
Transmitter Mounting and Cable Connector Options															
Meter Mount Converter		M													
IP68 Strain Relief [Remote Mount] (Standard)		R													
IP68 Quick Connect Potted Connector [Remote Mount]		Q													
Remote Cable Length Options															
Meter Mount Converter [No remote Cable]		000													
25 feet (Standard)		025													
50 feet		050													
75 feet		075													
100 feet		100													
125 feet		125													
150 feet		150													
175 feet		175													
200 feet		200													
500 feet		500													

continued on next page

Field Mag FM5 Part Number Matrix (cont.)

Transmitter Power Options									
A/C Power	A								
DC Power	D								
Transmitter Analog/Hart Output Options									
Single 4-20mA Analog, Dual Digital (Standard)	1								
Dual 4-20mA Analog, Dual Digital	2								
1 Hart 4-20mA Analog, 1 Standard 4-20mA Analog, Dual Digital	3								
Transmitter Digital Output Options									
No Digital Protocol Outputs									
Modbus Protocol	MOD								
Ethernet IP Protocol *Future Option	EIP								
Output Protocol Types									
No Digital outputs									
RTU (RS485) Output (Modbus)	R								
TCP/IP Output (Modbus, Ethernet IP)	E								
Smart Output Protocol / SmartTrax Options									
No AMI Outputs/ SmartTrax									
Sensus Protocol (6ft cable, Nicor Connector hardwired only)	SEN								
Itron 6 digit Protocol (6ft cable, Nicor Connector hardwired only)	IT6								
Itron 9 digit [100W] Protocol (6ft cable, Nicor Connector hardwired only)	IT9								
Neptune Protocol (6ft cable, Nicor Connector hardwired only)	NEP								
2 ft SmartTrax Standalone Unit ExactRead Cable (Strain Relief Only)	S02								
6 ft SmartTrax Standalone Unit ExactRead Cable (Strain Relief Only)	S06								
25 ft SmartTrax Standalone Unit ExactRead Cable (Strain Relief Only)	S25								
50 ft SmartTrax Standalone Unit ExactRead Cable (Strain Relief Only)	S50								
Non Standard Length Options									
McCrometer Length (Standard)									
Competitor Replacement Length	LS Select								
Competitor Replacement Length	LP Length								
Custom Specified Length (Not Offered on Victaulic)	L26								
Accuracy Options									
Standard Accuracy 0.5% Calibration									
High Accuracy 0.2% Calibration	HA								
Canadian Registration Certified									
No CRN Needed									
CRN Certified (Sizes 4-12" ANSI Flanges Only)	CRN								
Hazardous Area Location									
No Hazardous Location Needed									
Class 1, Division 2, Groups A-D, T5	HL								

ProComm GO Transmitter Specifications

Physical Specifications

Electronic Housing	Diecast aluminum, powder coated enclosure w/ tamper resistant seal, 6½" x 6½" x 43/8" tall
Transmitter Dimensions	See "Dimensions" section for meter mount and remote mount transmitter dimensions.
Power	Battery: Standard: three 3.6V lithium-thionyl chloride (Li-SOCl ₂) D size batteries with two AA backup batteries AC Power: 100-240VAC/45-66Hz (4W) DC Power: Linear power supply 10-35VDC (4 W)
Electrical Connections	<ul style="list-style-type: none"> • Optional shielded cable for 10-32VDC/4-20 mA output • Optional shielded cable for pulse out

Performance and Operational Specifications

Battery Life	Five-year expected battery life, five-year battery warranty
Location	Indoor or outdoor use
Altitude	Operating: 2000 meters Storage: 12,000 meters
Operating Temperature	-4° to 140° F (-20° to 60° C)
Storage Temperature	-4° to 140° F (-20° to 60° C)
Relative Humidity	0% to 100%
IP Rating	IP67 Die cast aluminum transmitter
Outputs	Digital output: Digital pulse (open collector) output for volumetric - Two isolated digital pulse (open collector) outputs for volumetric - AMI output Analog output: 4-20mA: Galvanically Isolated, 16 Bit resolution. All power configurations (including battery). Note: 9-30 VDC loop power required (not supplied via transmitter)

Display and Measurement

Display	<ul style="list-style-type: none"> • 2-Line LCD display (no backlight) • Non-volatile memory • Anti-reverse totalizer (standard) • Total (to 9 digits of precision) 	<ul style="list-style-type: none"> • Flow rate and velocity (to 5 digits of precision) • Two alarms: low battery and empty pipe (optional) • Opening lid activates display 																																																
Digits	5 Rate, 9 Total																																																	
Units	<table style="width: 100%; border-collapse: collapse;"> <tr> <td style="width: 25%;">GPM</td> <td style="width: 25%;">Gallons per minute</td> <td style="width: 25%;">IGM</td> <td style="width: 25%;">Imperial gal per minute</td> <td style="width: 25%;">CFM</td> <td style="width: 25%;">Cubic feet per minute</td> </tr> <tr> <td>MGD</td> <td>Mega gal per day</td> <td>MI9</td> <td>Miners inch (9G)</td> <td>B5M</td> <td>Barrels per minute (55G)</td> </tr> <tr> <td>CFS</td> <td>Cubic feet per second</td> <td>MI1</td> <td>Miners inch (11.22G)</td> <td>B5H</td> <td>Barrels per hour (55G)</td> </tr> <tr> <td>MLD</td> <td>Megaliters per day</td> <td>APD</td> <td>Acre feet per day</td> <td>B5D</td> <td>Barrels per day (55G)</td> </tr> <tr> <td>LPS</td> <td>Liters per second</td> <td>KLH</td> <td>Kiloliters per hour</td> <td>B4M</td> <td>Barrels per minute (42G)</td> </tr> <tr> <td>CMH</td> <td>Cubic meters per hour</td> <td>LPH</td> <td>Liters per hour</td> <td>B4H</td> <td>Barrels per hour (42G)</td> </tr> <tr> <td>LPM</td> <td>Liters per minute</td> <td>CMM</td> <td>Cubic meters per minute</td> <td>B4D</td> <td>Barrels per day (42G)</td> </tr> <tr> <td>GPH</td> <td>Gallons per hour</td> <td>CFM</td> <td>Cubic feet per minute</td> <td></td> <td></td> </tr> </table>		GPM	Gallons per minute	IGM	Imperial gal per minute	CFM	Cubic feet per minute	MGD	Mega gal per day	MI9	Miners inch (9G)	B5M	Barrels per minute (55G)	CFS	Cubic feet per second	MI1	Miners inch (11.22G)	B5H	Barrels per hour (55G)	MLD	Megaliters per day	APD	Acre feet per day	B5D	Barrels per day (55G)	LPS	Liters per second	KLH	Kiloliters per hour	B4M	Barrels per minute (42G)	CMH	Cubic meters per hour	LPH	Liters per hour	B4H	Barrels per hour (42G)	LPM	Liters per minute	CMM	Cubic meters per minute	B4D	Barrels per day (42G)	GPH	Gallons per hour	CFM	Cubic feet per minute		
GPM	Gallons per minute	IGM	Imperial gal per minute	CFM	Cubic feet per minute																																													
MGD	Mega gal per day	MI9	Miners inch (9G)	B5M	Barrels per minute (55G)																																													
CFS	Cubic feet per second	MI1	Miners inch (11.22G)	B5H	Barrels per hour (55G)																																													
MLD	Megaliters per day	APD	Acre feet per day	B5D	Barrels per day (55G)																																													
LPS	Liters per second	KLH	Kiloliters per hour	B4M	Barrels per minute (42G)																																													
CMH	Cubic meters per hour	LPH	Liters per hour	B4H	Barrels per hour (42G)																																													
LPM	Liters per minute	CMM	Cubic meters per minute	B4D	Barrels per day (42G)																																													
GPH	Gallons per hour	CFM	Cubic feet per minute																																															

ProComm GO Transmitter Specifications (cont.)



Display and Measurement (cont.)

Totalizer Units	GAL	Gallons	B42	Barrel (42G)	MH1	Miners Inch Hour (11.22G)
	CUF	Cubic Feet	B46	Barrel (46G)	MD1	Miners Inch Day (11.22G)
	AFT	Acre Feet	B55	Barrel (55G)	MH9	Miners Inch Hour (9G)
	CUM	Cubic Meters	IMG	Imperial Gallon	MD9	Miners Inch Day (9G)
	LIT	Liters	AIN	Acre Inch	KGL	Kilo Gallons
	MML	Megaliter	TON	Ton (Short)	MGL	Mega Gallons
	MTT	Metric Ton (KL)	MM1	Miners Inch Minute (11.22G)	IN3	Cubic Inch
	B31	Barrel (31G)	MM9	Miners Inch Minute (9G)		
	Data Logger	Standard with all models, minimum of five years of data stored				

Other Specifications

Options and Accessories	<ul style="list-style-type: none"> Data Logger - included as standard with five years of data storage at default (12hr) interval. (Cable sold separately) AC, DC, and battery powered with battery backup powered available
Safety	<ul style="list-style-type: none"> IEC 61010-1, Pollution Degree II Overvoltage protection Category III

Certifications

Standard Model	<ul style="list-style-type: none"> ISO 9001:2015 certified quality management system CE Certified by MET to UL 61010-1 	  
HL Model	<ul style="list-style-type: none"> ISO 9001:2015 certified quality management system CE Certified by MET to UL 61010-1 and MET C22.2 No. 61010-1-04 <ul style="list-style-type: none"> Class I, Division 2, Groups A B C D, T4 Class I, Zone 2, IIC T4 <p><i>Note: ProComm GO with SmartTrax On Board is not available for hazardous locations.</i></p>	

ProComm Max Transmitter Specifications

Physical Specifications

Electronic Housing	Diecast aluminum, powder coated enclosure w/ tamper resistant seal
Transmitter Dimensions	Remote Mount: Height: 7.3" (18.5 cm) Width: 8.5" (21.6 cm) Depth: 4.3" (10.9 cm)
	Meter Mount: Height: 6.9" (17.5 cm) Width: 7.2" (18.25 cm) Depth: 6.2" (15.7 cm)
Power	AC Power: 100-240 VAC / 47-66 Hz (10 W) DC Power: 10-35 VDC (10 W)
	Note: AC or DC must be specified at time of ordering.
Connection Options	Conduit option: 1/2" NPT threaded connections
Galvanic Isolation	All outputs are galvanically isolated from power supply up to 500 V
Conductivity	Minimum conductivity of 5µS/cm

Performance and Operational Specifications

Location	Indoor or outdoor use
Operating and Storage Temperature	-4° to 140° F (-20° to 60° C)
IP Rating	IP67 Die cast aluminum transmitter
Standard Outputs	Single 4-20mA (standard). Galvanically isolated and fully programmable for zero and full scale. A second 4-20mA is available. Two separate digital programmable outputs: open collector transistor usable for pulse, frequency, or alarm settings.
	<ul style="list-style-type: none"> • Volumetric Pulse • Range Indication • Maximum switching voltage: 35 VDC • Maximum switching current: 100mA • Insulation from other secondary circuits: 500V
Optional Outputs	<ul style="list-style-type: none"> <li style="width: 50%;">• Modbus <li style="width: 50%;">• Datalogger <li style="width: 50%;">• HART <li style="width: 50%;">• Smart Output™ (Sensus, Itron 6, Itron 9) <li style="width: 50%;">• Ethernet IP

Display and Measurement

Keyboard and Display	Can be used to access and change set-up parameters using six membrane keys and an LCD display					
Units	GAL	Gallons	B42	Barrel (42G)	MH1	Miners Inch Hour (11.22G)
	CUF	Cubic Feet	B46	Barrel (46G)	MD1	Miners Inch Day (11.22G)
	AFT	Acre Feet	B55	Barrel (55G)	MH9	Miners Inch Hour (9G)
	CUM	Cubic Meters	IMG	Imperial Gallon	MD9	Miners Inch Day (9G)
	LIT	Liters	AIN	Acre Inch	KGL	Kilo Gallons
	MML	Megaliter	TON	Ton (Short)	MGL	Mega Gallons
	MTT	Metric Ton (KL)	MM1	Miners Inch Minute (11.22G)	IN3	Cubic Inch
	B31	Barrel (31G)	MM9	Miners Inch Minute (9G)		

Other Specifications

- ISO 9001:2015 certified quality management system
- CE



ProComm GO Transmitter Dimensions

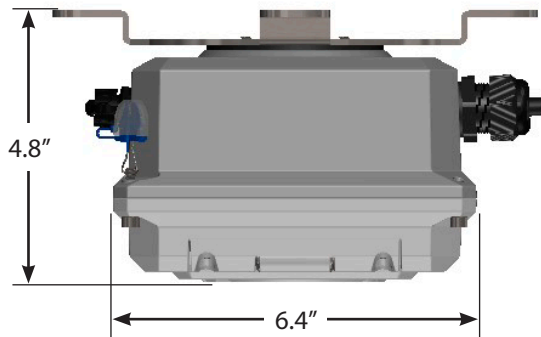
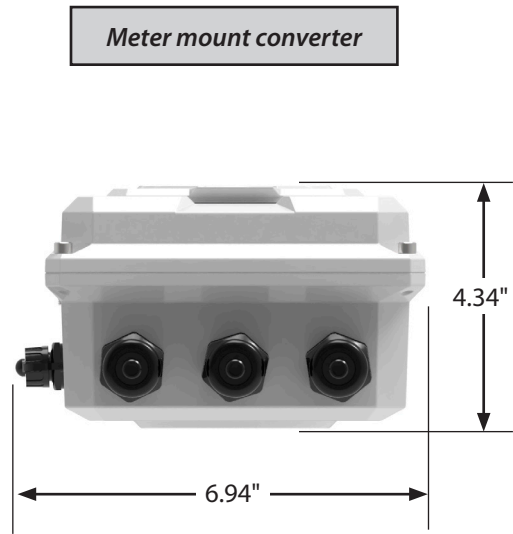
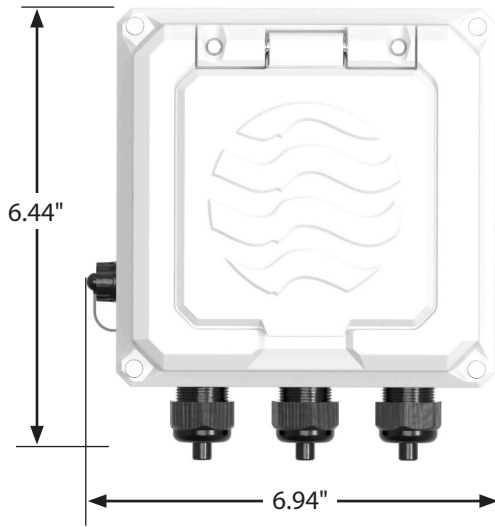

Remote mount converter

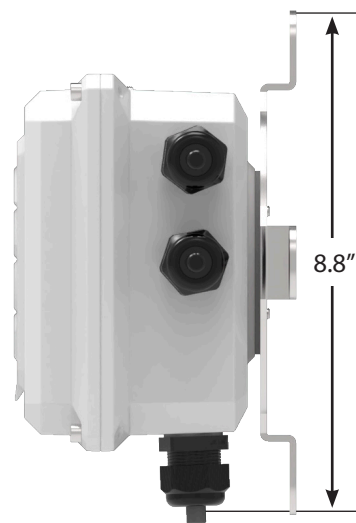
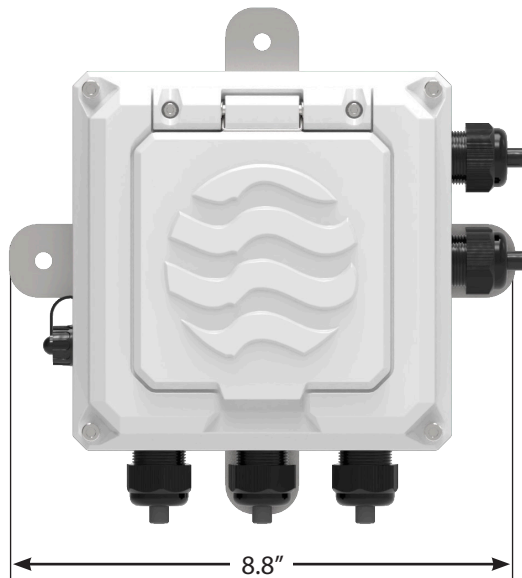

ProComm Max Transmitter Dimensions

Meter Mount Transmitter Dimensions

Height 6.9" (17.6 cm)
Width 7.4" (18.8 cm)
Depth 5.6" (14.2 cm)

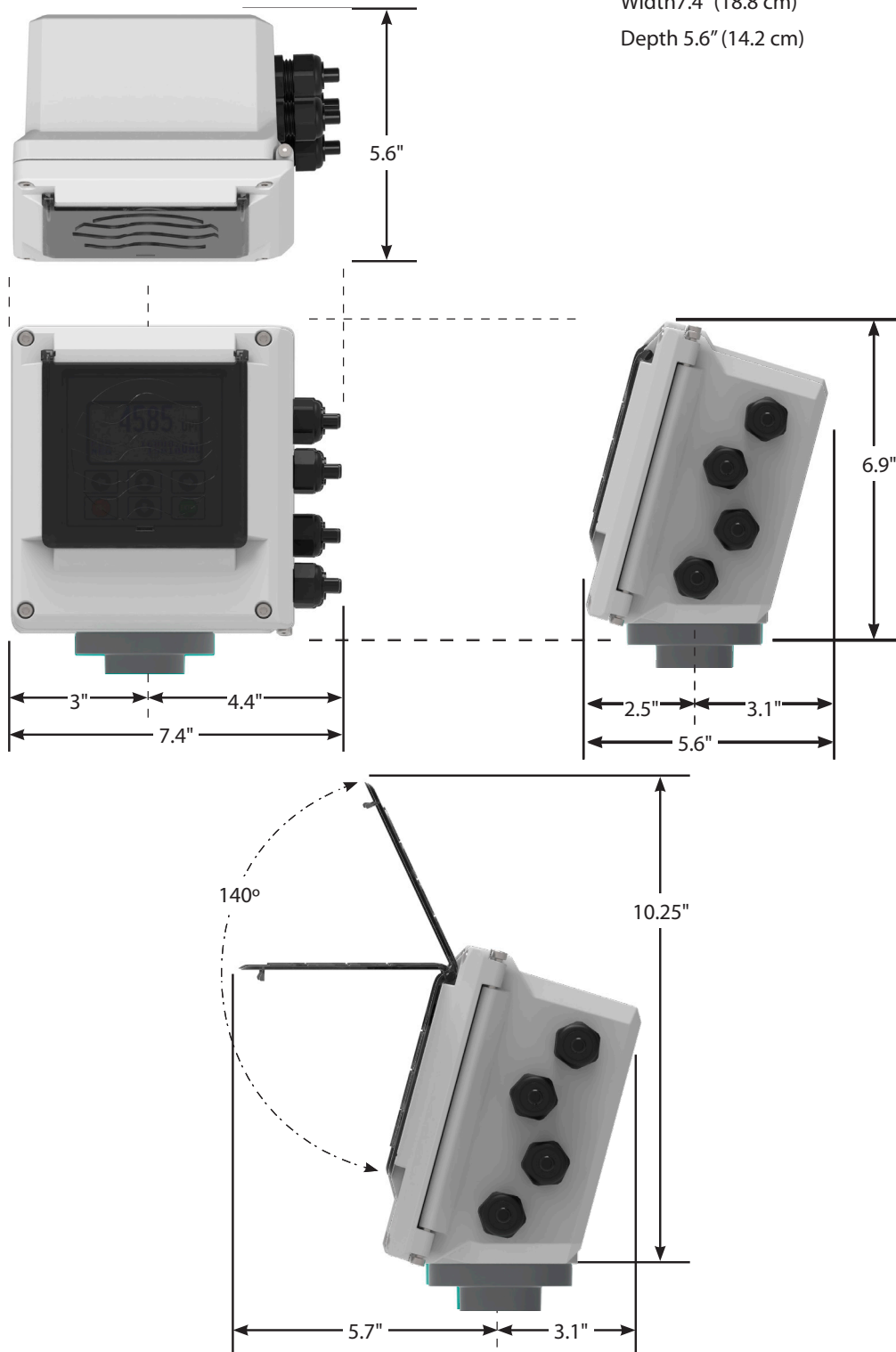

ProComm Max Transmitter Dimensions (cont.)

Height 7.4" (18.9 cm)
Width 8.5" (21.6 cm)
Depth 4.4" (11.2 cm)

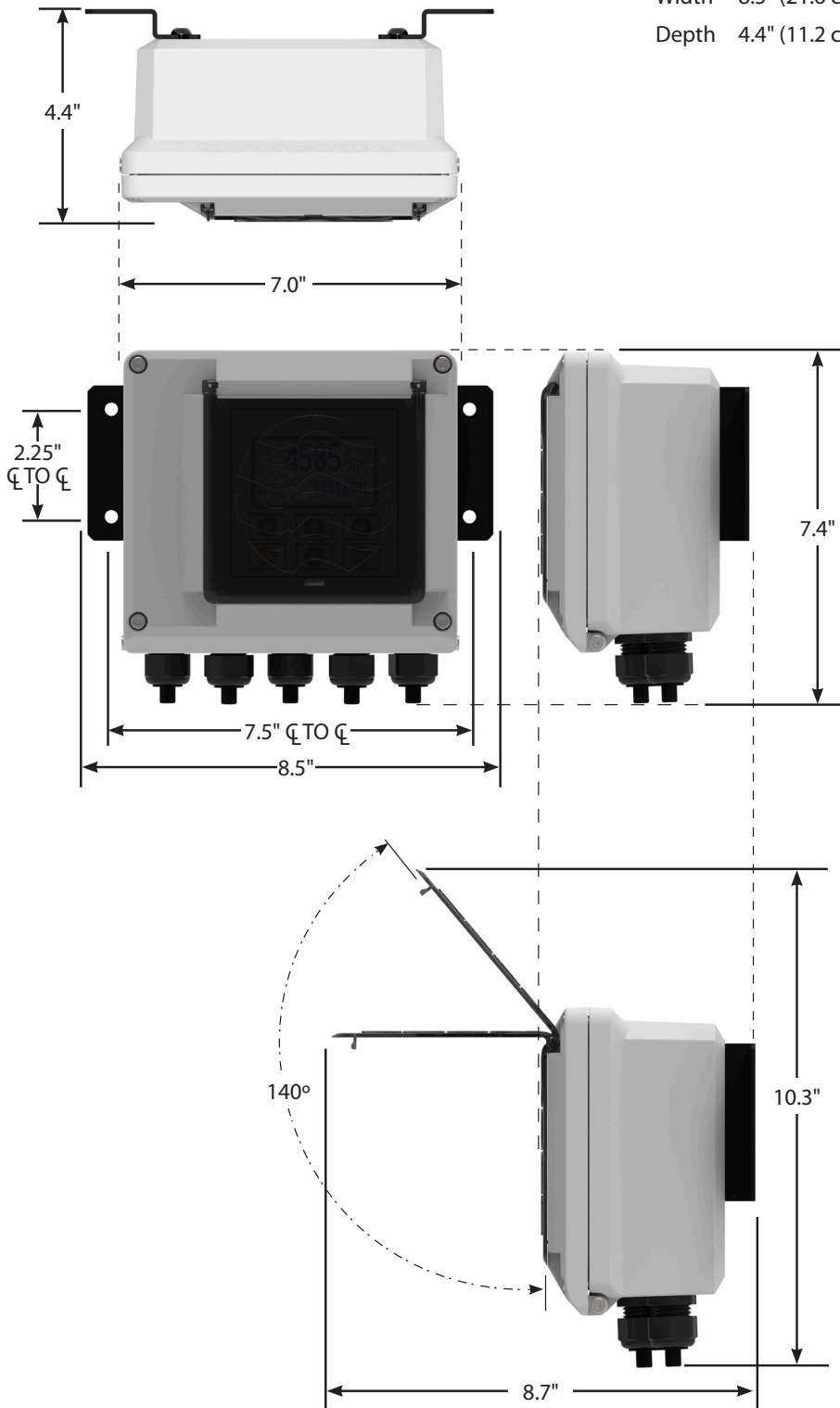

Copyright © 2024 McCrometer, Inc. All printed material should not be changed or altered without permission of McCrometer. Any published pricing, technical data, and instructions are subject to change without notice. Contact your McCrometer representative for current pricing, technical data, and instructions.

3255 WEST STETSON AVENUE • HEMET, CALIFORNIA 92545 USA
TEL: 951-652-6811 • 800-220-2279 • FAX: 951-652-3078
www.mccrometer.com