

FlowCom Digital Register for Water Specialties

Installation, Operation and Maintenance Manual



30126-98 Rev. 1.2
08MAY2025

Contents

SAFETY	1
Safety Symbols	1
Safety Warnings	1
1.0 OVERVIEW OF THE DIGITAL REGISTER	2
2.0 INSTALLING THE METER MOUNT FLOWCOM	2
2.1 Verify Serial Numbers	2
3.0 REMOTE MOUNT FLOWCOM INSTALLATION.....	2
3.1 Example Remote Mount Configuration	2
3.2 Mounting the Register.....	3
3.3 Installing Cables through Cable Glands and Conduit.....	3
3.4 Pulling Sensor Cable Through Electrical Conduit	4
3.5 Cable Gland Assignment for Wiring Harnesses	4
4.0 RETROFITTING AN EXISTING METER.....	5
4.1 Mechanical Register to FlowCom - Meter Mount	6
4.2 Old model FlowCom to new model - meter mount	11
4.3 Old FlowCom to New FlowCom Conversion - Remote Mount.....	16
5.0 INTERNAL WIRE CONNECTION.....	20
5.1 Terminal Block Diagram and Grounding Lug	20
5.2 Wiring Diagrams	21
5.3 Optional Smart Output Hook Up	22
5.4 Connecting the SmartTrax Remote Transmitting Unit.....	22
5.5 Pin-out of Male and Female Connectors	23
5.6 Installing the SmartTrax Optional Solar Panel.....	23
5.7 FlowCom with SmartTrax On Board.....	24
6.0 ACCESSING THE SMARTTRAX DATA.....	24
7.0 EXTERNAL WIRE CONNECTION	28
7.1 Cable Gland Connections	28
7.2 Pulse / 4-20 mA Outputs	28
7.3 4-20mA Current Loop	29
7.4 Pulse Output Cable (Optional)	29
8.0 BATTERY INSTALLATION AND REPLACEMENT	30
9.0 OPERATION	34
9.1 General.....	34
9.2 Activating the Display.....	34
9.3 Register Boot	35
10.0 REGISTER CONFIGURATION	35
11.0 SPECIFICATIONS.....	36
12.0 DIMENSIONS	38
WARRANTY STATEMENT	39

SAFETY

Safety Symbols

Throughout this manual are safety warning and caution information boxes. Each warning and caution box will be identified by a large symbol indicating the type of information contained in the box. The symbols are explained below:



This symbol indicates important safety information. Failure to follow the instructions can result in serious injury or death.



This symbol indicates important information. Failure to follow the instructions can result in permanent damage to the meter or installation site.

Safety Warnings

When installing, operating, and maintaining McCrometer equipment where hazards may be present, you must protect yourself by wearing Personal Protective Equipment (PPE) and be trained to enter confined spaces. Examples of confined spaces are manholes, pumping stations, pipelines, pits, septic tanks, sewage digesters, vaults, degreasers, storage tanks, boilers, and furnaces.



WARNING!

Incorrect installation or removal of mag meters can result in serious injury or death. Read the instructions in this manual on the proper procedures carefully.



WARNING!

Never enter a confined space without testing the air at the top, middle, and bottom of the space. The air may be toxic, oxygen deficient, or explosive. Do not trust your senses to determine if the air is safe. You cannot see or smell many toxic gases.



WARNING!

Never enter a confined space without the proper safety equipment. You may need a respirator, gas detector, tripod, lifeline, and other safety equipment.



WARNING!

Never enter a confined space without standby/rescue personnel within earshot. Standby/rescue personnel must know what action to take in case of an emergency.



WARNING!

Pressurized pipes should only be hot tapped, cut, or drilled by qualified personnel. If possible, depressurize and drain the pipe before attempting any installation.



WARNING!

Carefully read all safety warning tags attached to the meter.



At the end of its lifetime, this product shall be disposed of in full compliance with the environmental regulations of the state in which it is located.

1.0 OVERVIEW OF THE DIGITAL REGISTER

Read this entire manual prior to installation and/or changing any settings. Retain this manual in your records, DO NOT DISCARD.

The digital register is the reporting, input and output control device for the sensor. It allows the measurements, functional programming, control of the sensor and data recording to be communicated through the display and inputs & outputs. The microprocessor-based signal digital register has a rugged enclosure that meets IP67. The microprocessor continually monitors the digital register’s functionality. The digital register will output rate of flow and total volume. It also comes many more features that is fully user-configurable using the configuration tool via the USB port and a laptop computer.

2.0 INSTALLING THE METER MOUNT FLOWCOM

New Water Specialties flow meters with a meter mount FlowCom digital register will be fully assembled and functional. They arrive ready to be installed. You will need to perform a set-up routine when the digital register is activated to set your preferences using the configuration software, as described in section 10.0.

2.1 Verify Serial Numbers

The digital register and propeller meter are supplied as a matched system. Verify the serial numbers on both the digital register and propeller meter match. This will ensure a properly calibrated system. The serial number tag is located on the side or top of the digital register. The tag has the digital register model number, the digital register serial number, the meter model number and the meter serial number.

I Installation to be in accordance with any applicable restrictions of the NEC for the US or CE Code, Part I for Canada, including issues such as routing, support and length of the wiring method.

3.0 REMOTE MOUNT FLOWCOM INSTALLATION

3.1 Example Remote Mount Configuration

After installing the sensor, mount the digital register and connect the cable to the meter’s junction box and the digital register’s external connection. Figure 1 below shows an example of a remote mount installation with an optional Smart Output connection.

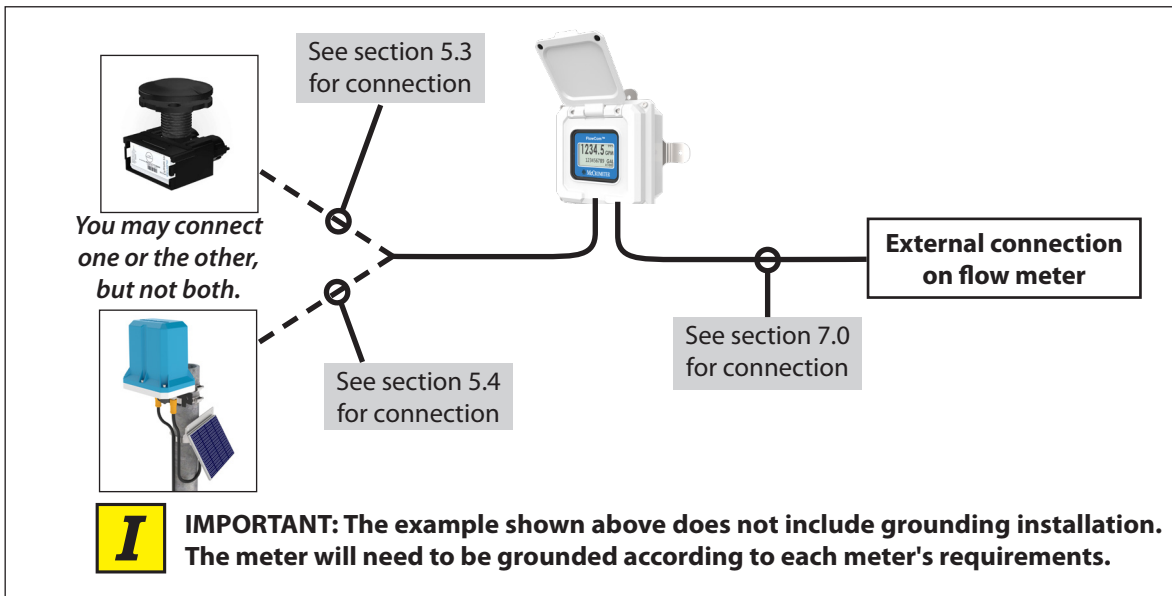

Figure 1. Example remote mount configuration

3.3 Mounting the Register

Note: *This applies to the remote mount register only.*

If possible, mount the register in an electronics shed or environmental enclosure. The sun shield should be oriented in a direction to reduce sun damage and ensure readability. This electronic unit is rated IP67 for temporary flooding.

There is a stainless steel mounting plate attached to the back of the register, which is used to mount the register to a solid, flat surface using four bolts (Figure 2). Mounting plate feet are located at the top, bottom, left, and right sides.

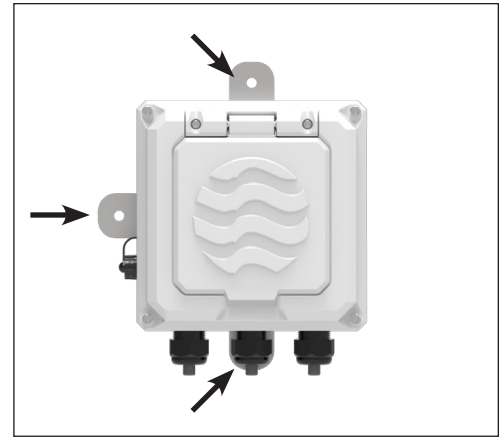

Figure 4. Mounting register to solid surface

3.2 Installing Cables through Cable Glands and Conduit

All electrical cables enter the register through compression fittings or optional customer-supplied conduit located on the side or bottom of the register (Figure 3 and Figure 4). Ensure that all compression glands are properly tightened and all unused fittings are plugged so the case remains sealed.

The power cable and wiring harnesses are each assigned specific cable glands where they will pass through into the register. See section 3.5 for cable gland assignment for wiring harnesses and section 5.2 for wiring diagrams.

All cable compression glands must be properly tightened to prevent moisture intrusion and maintain the IP67 rating. To insure IP67 rating, use only round cable 0.24" to 0.47" in diameter.



Figure 3. Compression fittings

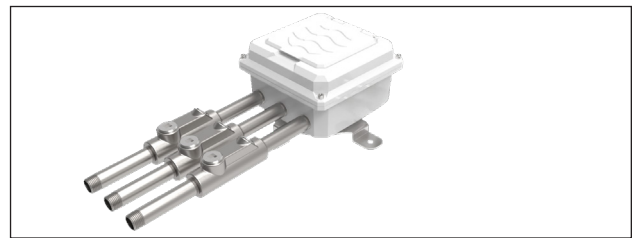

Figure 2. Remote mount register with conduit pass-throughs

3.5 Pulling Sensor Cable Through Electrical Conduit

It is very important to protect the end of the sensor cable when pulling it through a conduit. Water can accumulate in low portions of conduit. Always use a cable cover, or similar method, to seal the end of the cable against water when pulling the cable through conduit (see Figure 5). This will ensure proper operation of the meter.

1. Tie a rope or cable-snake securely around the middle of the cable cover.
2. Carefully pull the rope or snake until the sensor cable end clears the conduit.
3. Bring the cable end to the register location. If necessary, secure the cable so that it does not fall back through the conduit.
4. Remove the cable cover by pulling the rip wire. The cable cover will tear off (discard the cover).

NOTE Cable cover is not provided.

I CAUTION: Do not cut the cable cover off. Doing so may damage the sensor cable and adversely effect the calibration of the meter.

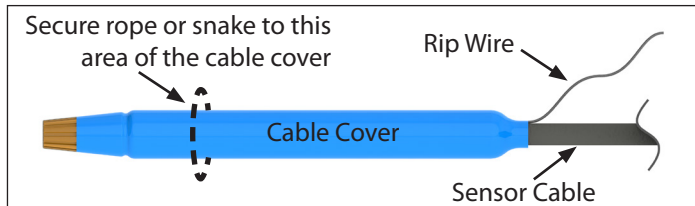

Figure 7. Example of cable cover

3.4 Cable Gland Assignment for Wiring Harnesses

Port assignment

- 1 - Outputs**
- 2 - Sensor**
- 3 - Remote Cable**



Figure 6. Meter mount view

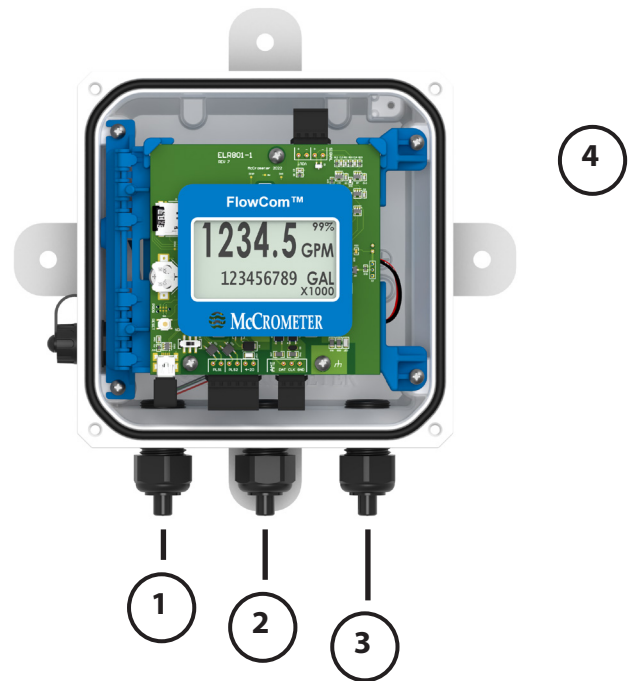

Figure 5. Remote mount view

4.0 RETROFITTING AN EXISTING METER

After unpacking the register assembly, verify that the meter serial number engraved on the enclosure lid is correct. Then confirm the information on a white label located on the side of the base plate.

Mechanical register to new FlowCom unit

Meterhead assembly

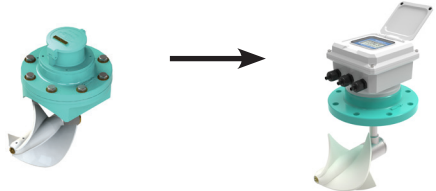

Strap-on saddle assembly

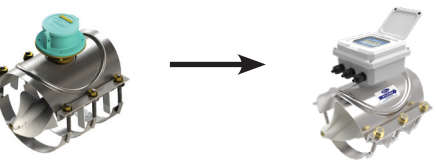

- STEP 1: Remove the flowmeter
- STEP 2: Remove the totalizer assembly
- STEP 3: Remove the gearbox assembly
- STEP 4: Disassemble the gearbox assembly
- STEP 5: Feed the sensor wiring through the meterhead and base plate
- STEP 6: Attach the FlowCom

FlowCom digital register to new FlowCom unit

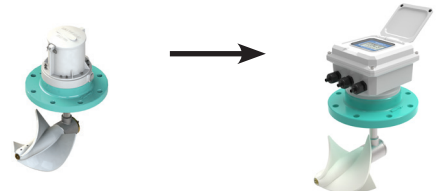

Strap-on saddle assembly

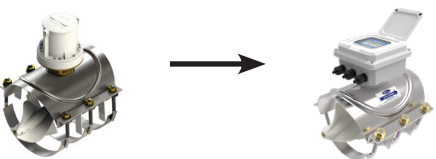

- STEP 1: Remove the flowmeter
- STEP 2: Disconnect external wiring connections
- STEP 3: Remove the old FlowCom unit from the meterhead
- STEP 4: Disassemble the gearbox assembly.
- STEP 5: Replace the internal sensor
- STEP 6: Feed the sensor wiring through the meterhead and base plate
- STEP 7: Attach the FlowCom

Remote mount FlowCom digital register to new FlowCom unit

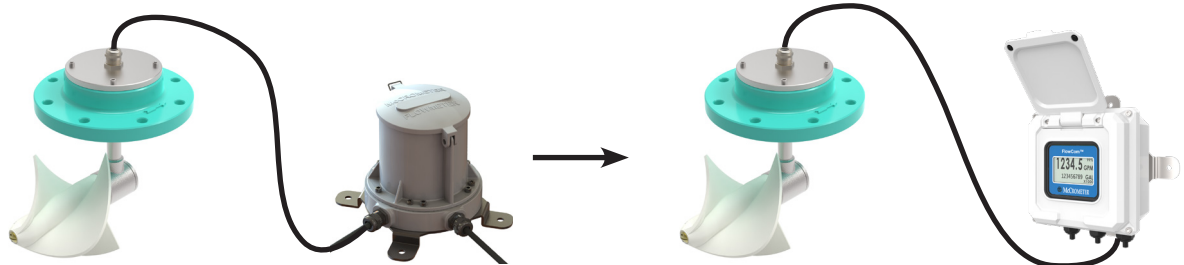

- STEP 1: Plan the cable run for the conversion
- STEP 2: Disconnect external wiring connections
- STEP 3: Remove the flow meter
- STEP 4: Remove the meter head plate and the submersible remote mount kit
- STEP 5: Connect the wiring and attach the meter head plate
- STEP 6: Extend the remote mount FlowCom cable run
- STEP 7: Mount the FlowCom on the platform and connect the wiring

4.1 Mechanical Register to FlowCom - Meter Mount

Check the parts received against the parts list. Contact the factory to report any discrepancies.

STEP 2: Remove the flowmeter



CAUTION! Never remove a meter or top plate assembly while the line is under pressure!

Remove pressure from the pipeline.

Remove the entire flowmeter from the pipeline.

STEP 1: Remove the totalizer assembly

Remove the entire totalizer or indicator-totalizer register assembly. Register models with totalizers have four bonnet screws and models with both the indicators and totalizers have four bonnet screws and two register screws. Remove the shaft.

For ML and LP meters: Remove the V-shaft by loosening the two screws holding the V-shaft from the inside of the meter head.

For ML and LP meters with extensions and for OF and VF meters: Pull vertical shaft out only enough (approximately 1") for removal of miter gear frame assembly so that the vertical shaft can be used later for pulling the sensor input cable out of the drop pipe.

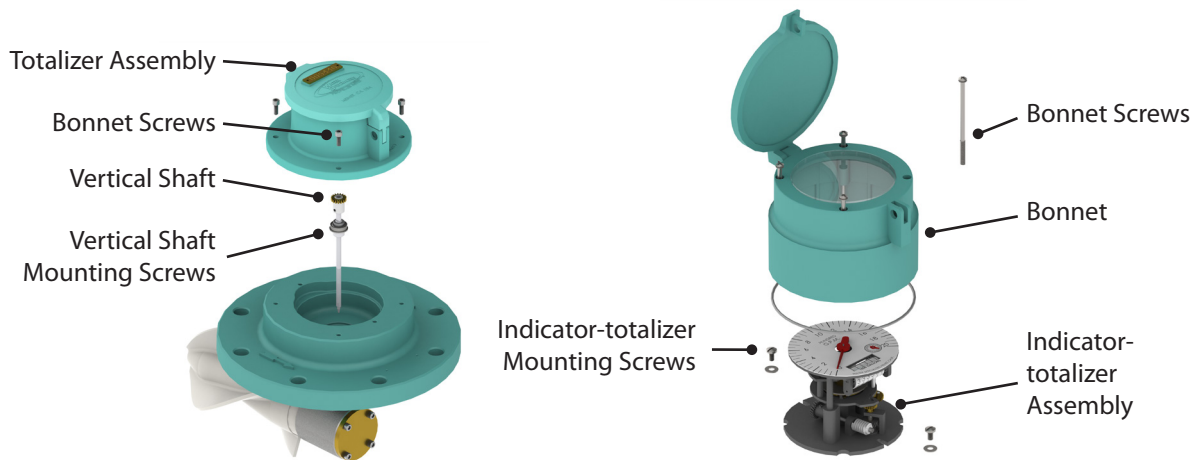

4.1 Mechanical Register to FlowCom - Meter Mount (cont.)

STEP 4: Remove the gearbox assembly

Note: See your flow meter's IOM manual for instructions on removing the propeller.

For ML, LP, and OF meters:

Remove the miter gear frame assembly by releasing the four screws out of the back of the gearbox.

Caution: The gearbox oil will begin draining as soon as the seal is broken.

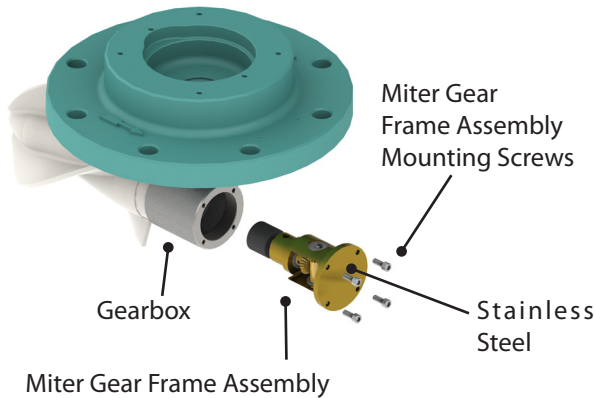

For VF meters:

Remove the propeller and the separator-spindle assembly.

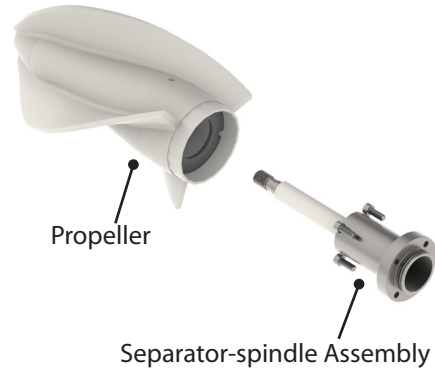

STEP 3: Disassemble the gearbox assembly

Before you begin, make sure the gearbox or drop pipe and separator/spindle assembly are dry and free of oil.

For ML and LP meters: Push the sensor assembly through the back of the gearbox all the way into the separator/spindle assembly. Rotate the sensor assembly so that the sensor cable can be fed through gearbox up over the meter head. Put a thin film of silicon grease on the O-ring and secure the back plate of the gearbox with four screws.

Note: Do not twist the back plate. This can cause the O-ring to be pinched and the meter to leak.

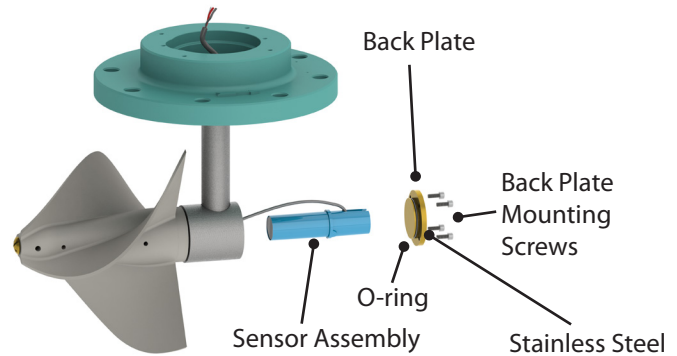

For OF and 24" to 54" ML meters: Attach pulling fixture T-2730-2 to bottom tip of existing vertical shaft assembly. Tighten both set screws on the fixture with a 0.062 Allen wrench for a secure connection to the vertical shaft tip. Loop sensor cable through hook on fixture and secure with a small piece of tape. Keep the sensor cable tight to allow passage through drop pipe bushings.

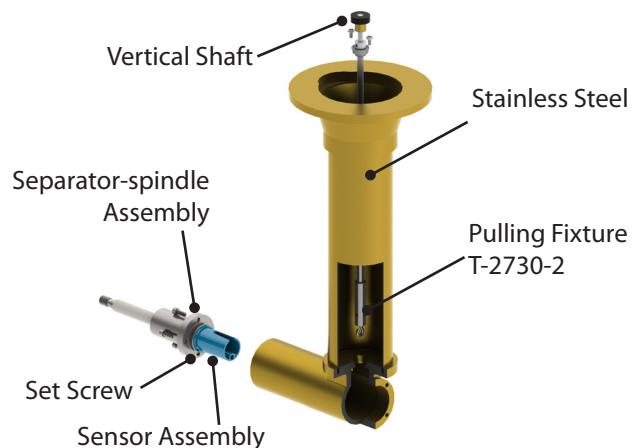

4.1 Mechanical Register to FlowCom - Meter Mount (cont.)

For VF meters: Push the sensor assembly all the way into separator/spindle assembly and then tighten the set screw to secure the position of the sensor assembly.

Note: The sensor cable must be positioned as shown.

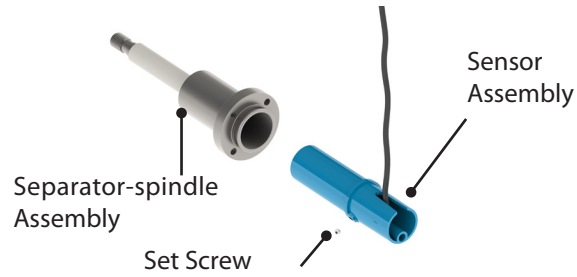

Then tie the sensor cable to the magnet end of the vertical shaft to assist in pulling the cable through. Leave approximately a 4" tale from the knot to the end connector so that magnet and cables can pass through the drop pipe end. At last, reinstall the propeller and separator/spindle assembly.



STEP 5: Feed the sensor wiring through the meterhead and base plate

The connection shown below is typical of all Water Specialties flow meters.

- | | |
|--|--|
| <ul style="list-style-type: none"> a. Clean the meter head surface of all dirt, glue, gaskets, etc. b. Verify that an O-ring is installed at the bottom of the electronic register base plate. c. Feed the sensor cable through the base plate and the cable gland. | <ul style="list-style-type: none"> a. Set the base plate on the meterhead. b. Attach the base plate to the meterhead with four screws. |
|--|--|

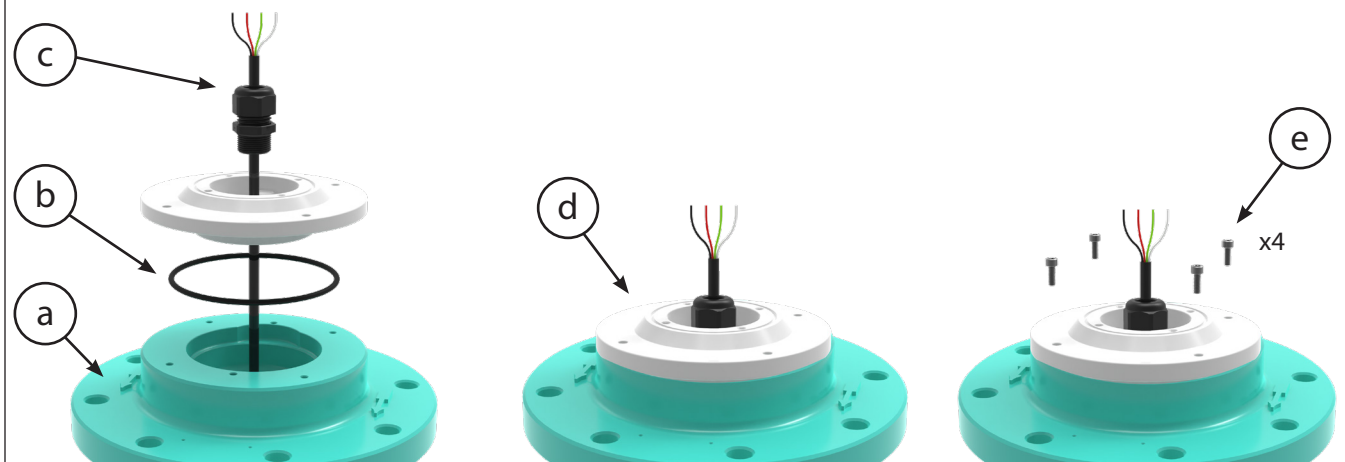

4.1 Mechanical Register to FlowCom - Meter Mount (cont.)

STEP 6: Attach the FlowCom

a. Remove the cover of the FlowCom unit.

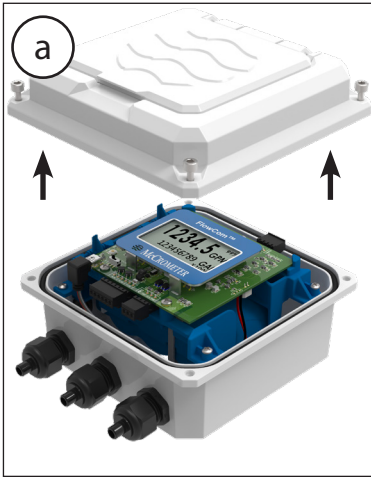

a. Remove the two screws that secure the battery tray and lift it up to expose the bottom of the FlowCom unit.

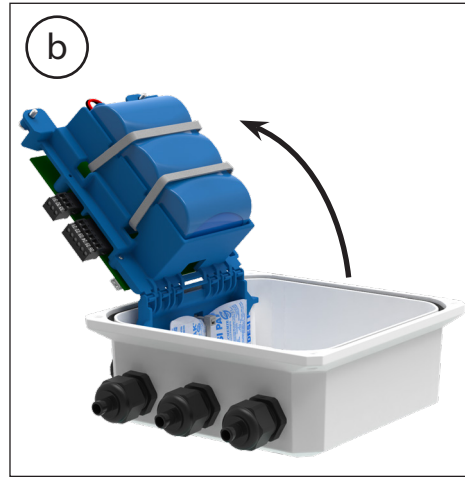

- a. Apply silicone grease and place the O-ring on the meterhead base.
- b. Feed the sensor cable through the bottom of the FlowCom unit.
- c. Place the FlowCom unit on the meterhead base and secure it to the base with four screws.

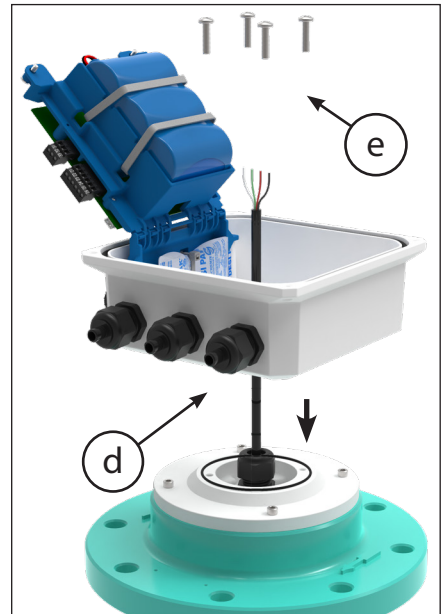
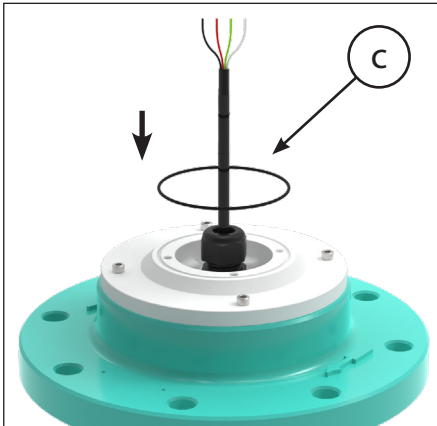

NOTE: When the FlowCom is attached to the base plate, it can be oriented in four possible ways. This affects how the register is read when the flowmeter is installed in the pipe. The preferred orientation needs to be selected before the FlowCom is attached to the base plate. The FlowCom's orientation is not affected by the flow direction.

The FlowCom can be attached so that it is aligned with the pipe. This orientation allows the meter to be read when viewed on either side of the pipe.

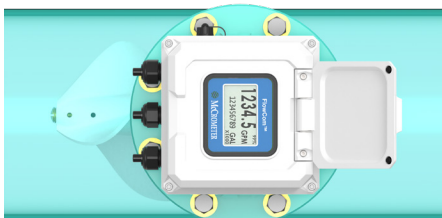

If the FlowCom will only be viewed from one perspective, it should be oriented as shown below.

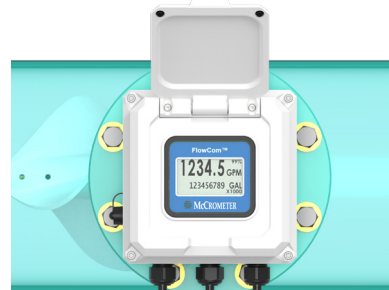

4.1 Mechanical Register to FlowCom - Meter Mount (cont.)

- a. Connect the cable from the FlowCom to the terminal block matching the the red, black, green, and white wires.

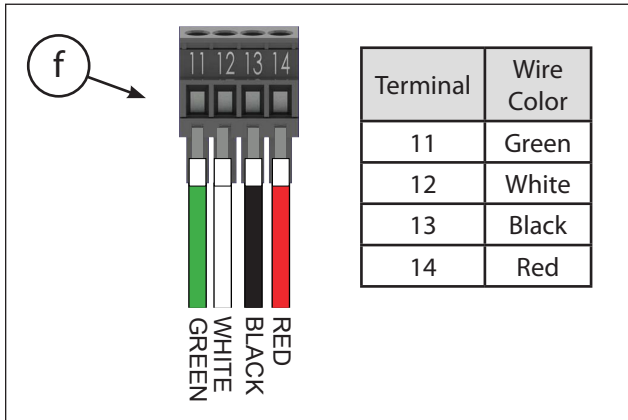

- a. Set the battery tray in place and secure with two screws.
- b. Connect the terminal block to the junction at the rear.

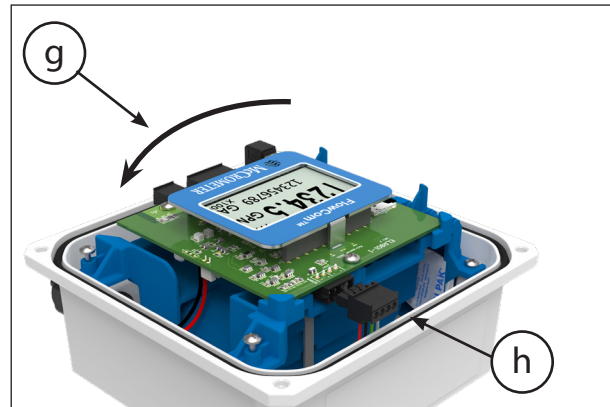

- a. Secure the cover.

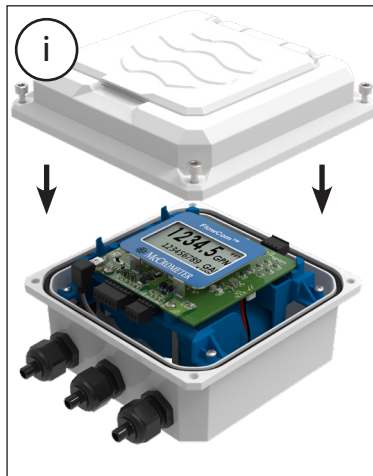

- a. Guide the wire for the tamper-proof seal through the hole in the screw.
- b. Thread the wire through the body of the tamper proof seal.

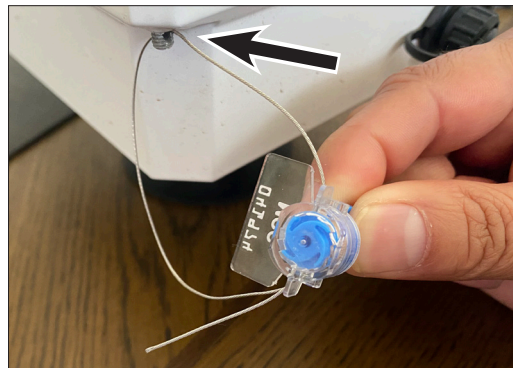

- a. Rotate the blue part on the tamper proof seal to bring in the wire and secure the seal close to the screw.

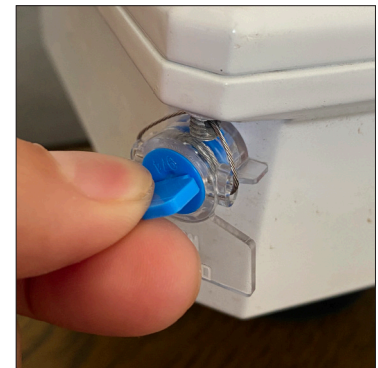

Reinstall the meter in the pipe. when the new FlowCom unit has been installed on the flow meter.

4.2 Old model FlowCom to new model - meter mount

Check the parts received against the parts list. Contact the factory to report any discrepancies.

STEP 1: Remove the flowmeter

- a. Remove pressure from the pipeline.
- b. Remove the entire flowmeter from the pipeline.

CAUTION! Never remove a meter or top plate assembly while the line is under pressure!

STEP 8: Disconnect external wiring connections

The FlowCom digital register must be completely disconnected from any external connections.

This includes:

- SCADA
- Power supply
- Grounding

If the old FlowCom unit is going to be used elsewhere, the ground wire and 4-20mA cable can be disconnected from the SCADA unit and the earth ground.

If the old FlowCom unit is not going to be used elsewhere, the 4-20 cable can be cut to facilitate the FlowCom's removal.

The 4-20mA cable connection inside the flowCom unit does not need to be unplugged if it is going to be re-used. If unplugging the cable is desired, the image at right shows where the terminal block plugs into the circuit board.

The old FlowCom unit must be entirely disconnected before proceeding to the next step.

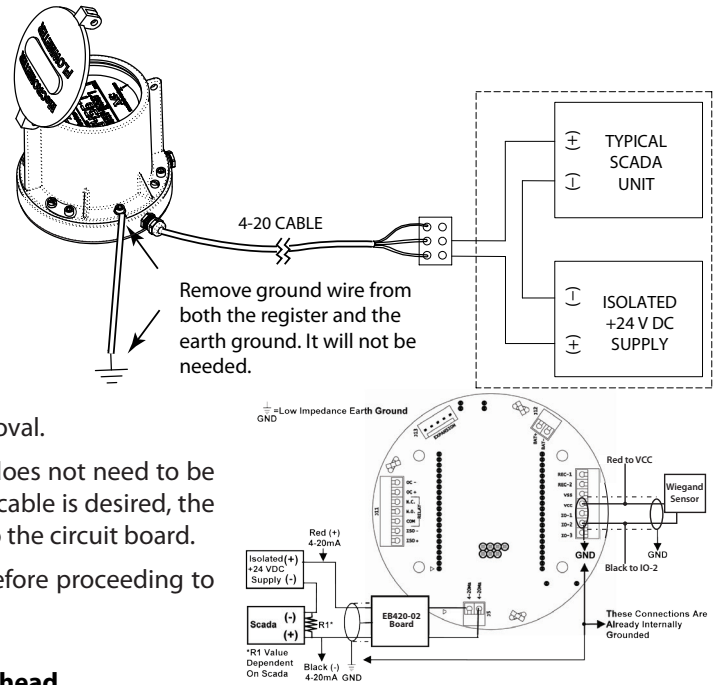

STEP 7: Remove the old FlowCom unit from the meterhead

- a. Detach the FlowCom from the mounting plate with the provided screws.
- b. Disconnect the cable from the FlowCom from the inline terminal block matching the the red, black, and green wires.
- c. Disconnect the sensor wire from the inline terminal block.
- d. Lift the base from from the meterhead.

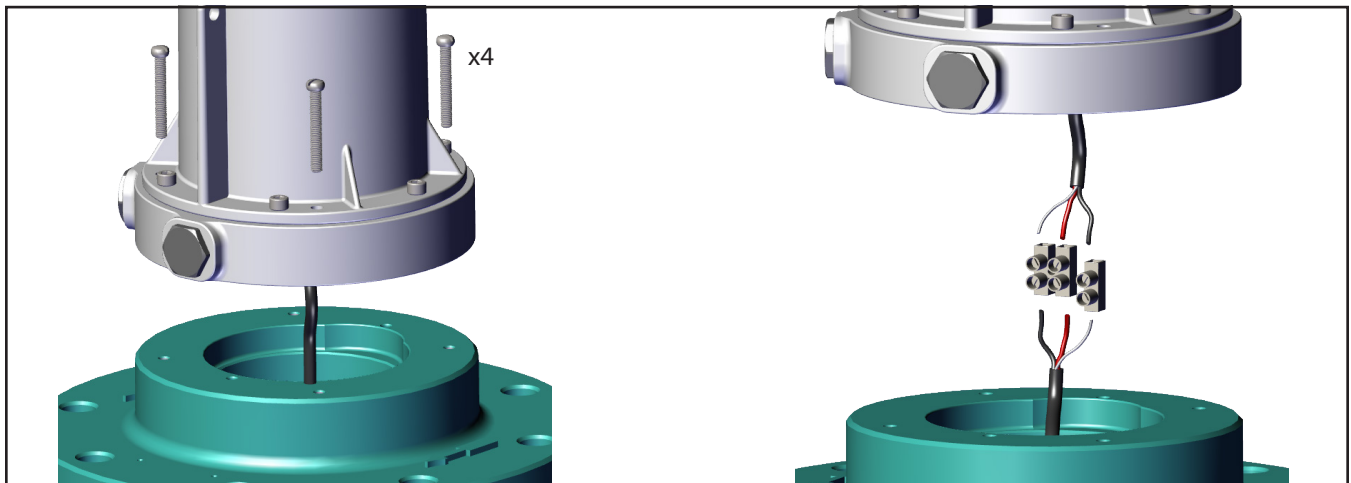

4.2 Old model FlowCom to new model - meter mount (cont.)

STEP 2: Disassemble the gearbox assembly.

Before you begin, make sure the gearbox or drop pipe and separator/spindle assembly are dry and free of oil.

For ML and LP meters: Push the sensor assembly through the back of the gearbox all the way into the separator/spindle assembly. Rotate the sensor assembly so that the sensor cable can be fed through gearbox up over the meter head. Put a thin film of silicon grease on the O-ring and secure the back plate of the gearbox with four screws.

Note: Do not twist the back plate. This can cause the O-ring to be pinched and the meter to leak.

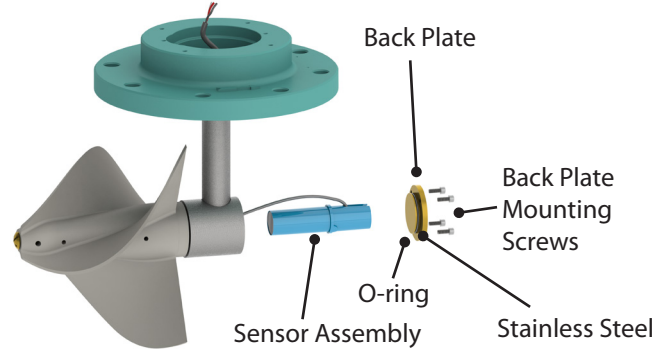

For OF and 24" to 54" ML meters: Attach pulling fixture T-2730-2 to bottom tip of existing vertical shaft assembly. Tighten both set screws on the fixture with a 0.062 Allen wrench for a secure connection to the vertical shaft tip. Loop sensor cable through hook on fixture and secure with a small piece of tape. Keep the sensor cable tight to allow passage through drop pipe bushings.

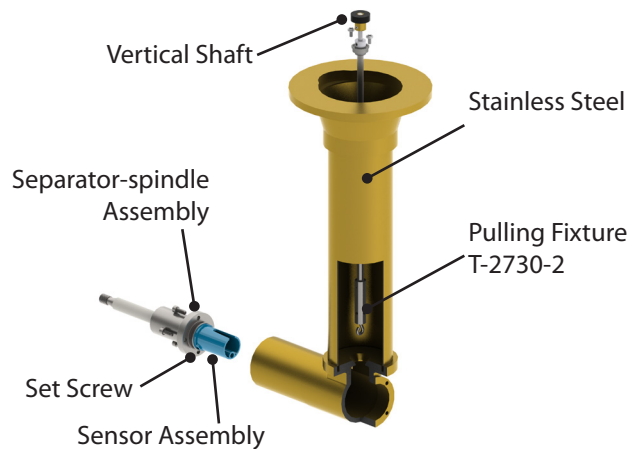

For VF meters: Push the sensor assembly all the way into separator/spindle assembly and then tighten the set screw to secure the position of the sensor assembly.

Note: The sensor cable must be positioned as shown.

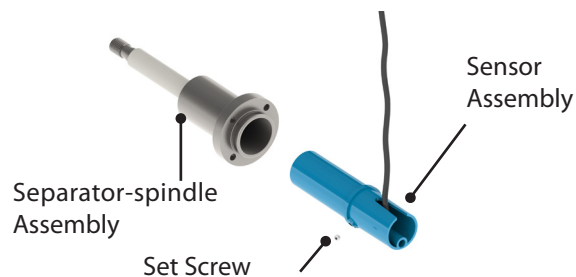

Then tie the sensor cable to the magnet end of the vertical shaft to assist in pulling the cable through. Leave approximately a 4" tale from the knot to the end connector so that magnet and cables can pass through the drop pipe end. At last, reinstall the propeller and separator/spindle assembly.



4.2 Old model FlowCom to new model - meter mount (cont.)

STEP 5: Replace the internal sensor

The sensor used in the old FlowCom unit is not compatible with the new FlowCom unit. It will need to be replaced as follows:

- a. Remove the existing sensor from the bearing assembly. Remove the backplate and sensor from existing meter.
- b. Insert the replacement the sensor through the gearbox and into the separator.
- c. Install new O-rings on the back plate. NOTE: it is recommended to use a silicone grease on the new O-rings to assist with sealing.
- d. Push the sensor cable up through the gearbox.
- e. Install and tighten the back plate.

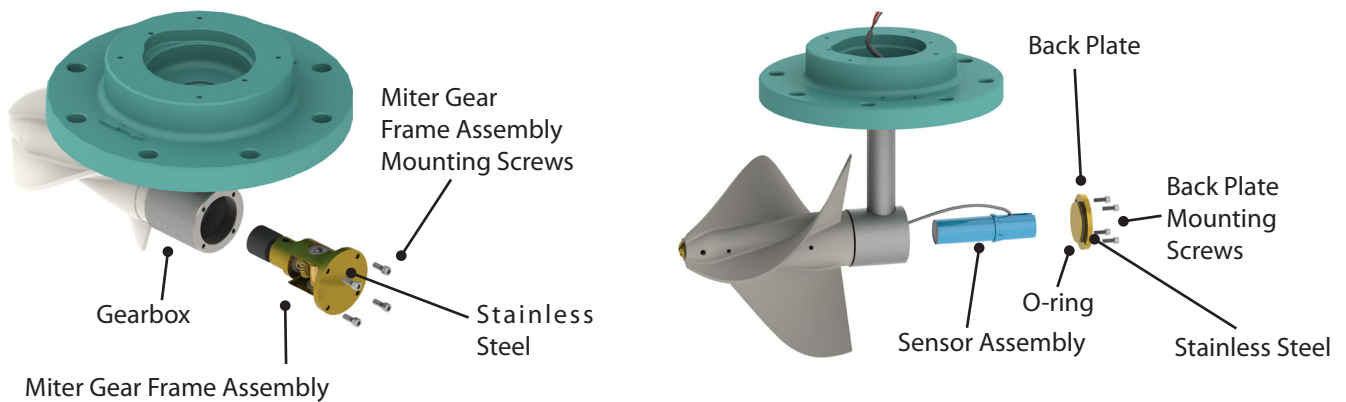

STEP 4: Feed the sensor wiring through the meterhead and base plate

The connection shown below is typical of all Water Specialties flow meters.

- | | |
|--|--|
| <ol style="list-style-type: none"> a. Clean the meter head surface of all dirt, glue, gaskets, etc. b. Verify that an O-ring is installed at the bottom of the electronic register base plate. c. Feed the sensor cable through the base plate and the cable gland. | <ol style="list-style-type: none"> a. Set the base plate on the meterhead. b. Attach the base plate to the meterhead with four screws. |
|--|--|

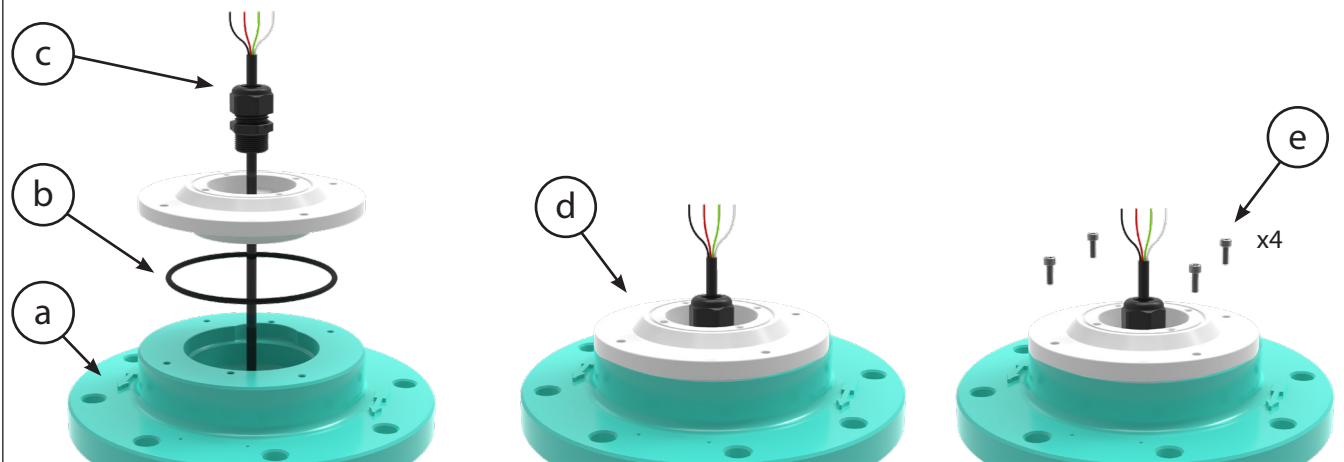

4.2 Old model FlowCom to new model - meter mount (cont.)

STEP 6: Attach the FlowCom

a. Remove the cover of the FlowCom unit.

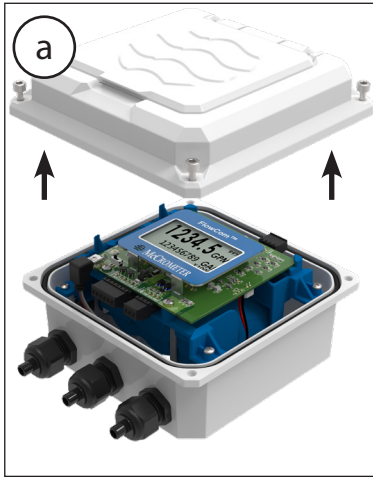

a. Remove the two screws that secure the battery tray and lift it up to expose the bottom of the FlowCom unit.

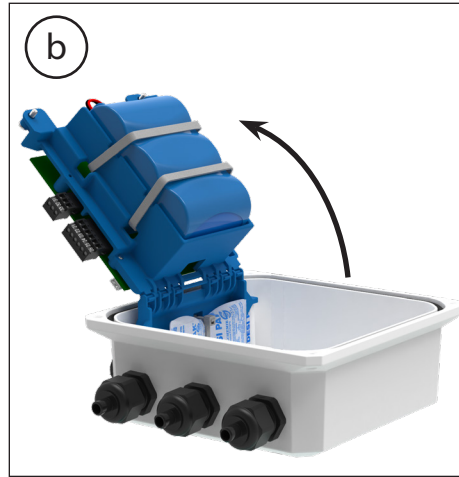

- a. Apply silicone grease, place the O-ring on the meterhead base.
- b. Feed the sensor cable through the bottom of the FlowCom unit.
- c. Place the FlowCom unit on the meterhead base and secure it to the base with four screws.

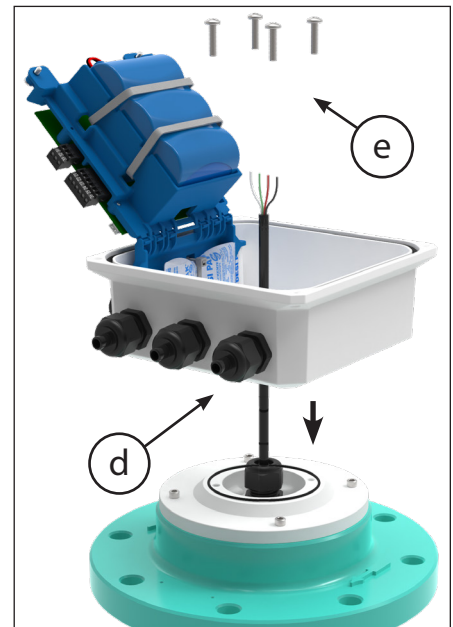
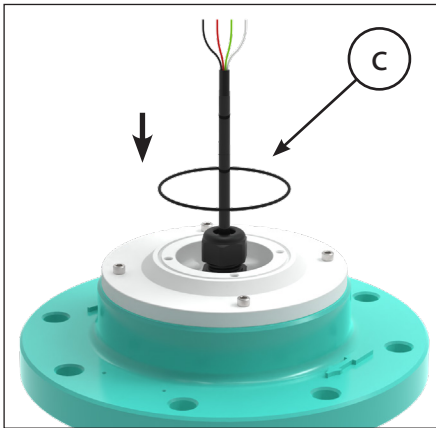

NOTE: When the FlowCom is attached to the base plate, it can be oriented in four possible ways. This affects how the register is read when the flowmeter is installed in the pipe. The preferred orientation needs to be selected before the FlowCom is attached to the base plate. The FlowCom's orientation is not affected by the flow direction.

The FlowCom can be attached so that it is aligned with the pipe. This orientation allows the meter to be read when viewed on either side of the pipe.

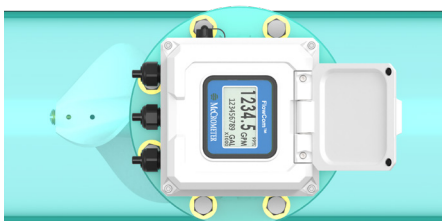

If the FlowCom will only be viewed from one perspective, it should be oriented as shown below.



4.2 Old model FlowCom to new model - meter mount (cont.)

- a. Connect the cable from the FlowCom to the terminal block matching the the red, black, green, and white wires.

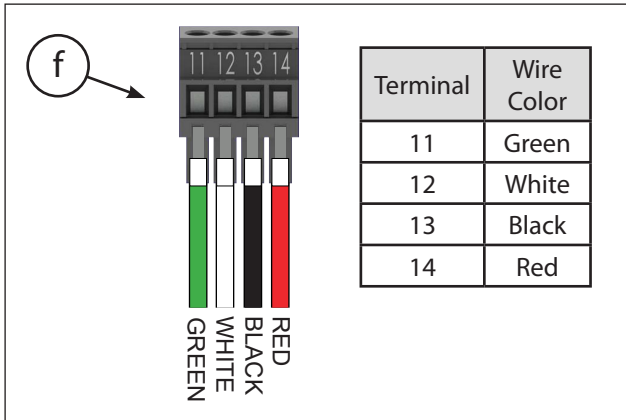

- a. Set the battery tray in place and secure with two screws.
- b. Connect the terminal block to the junction at the rear.

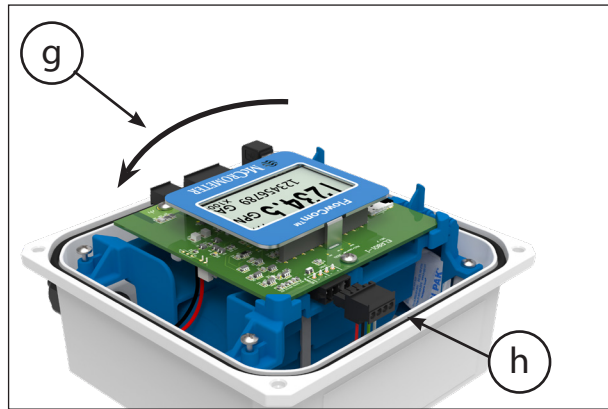

- a. Secure the cover.

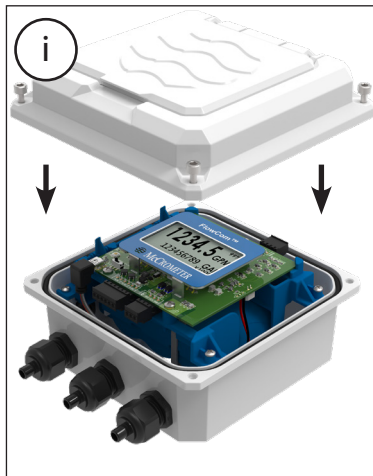

- a. Guide the wire for the tamper-proof seal through the hole in the screw.
- b. Thread the wire through the body of the tamper proof seal.

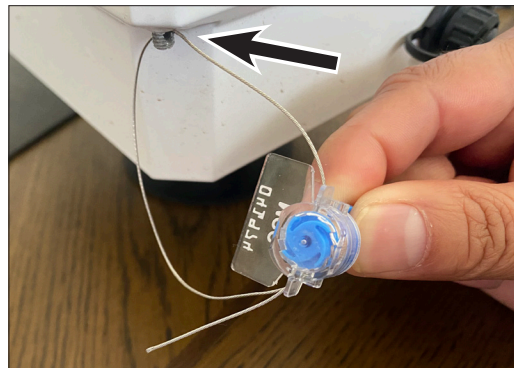

- a. Rotate the blue part on the tamper proof seal to bring in the wire and secure the seal close to the screw.



Reinstall the meter in the pipe. when the new FlowCom unit has been installed on the flow meter.

4.3 Old FlowCom to New FlowCom Conversion - Remote Mount

STEP 1: Plan the cable run for the conversion

I If this is for a new FlowCom installation, **follow the procedure in section 3.0 for new remote mount FlowCom installations.** The following instructions are for retrofitting an existing remote mount installation.

Before you remove the flow meter, you should already know the location of the remote mount FlowCom unit. If you are replacing the old unit, you will need to remove the sensor cable and replace it with the new cable for the entire cable run. The old cable is not compatible with the new FlowCom unit.

Check the parts received against the parts list. Contact the factory to report any discrepancies.

I IMPORTANT: Do not cut or alter the cable length on power or signal cables!

The cable between the sensor and the transmitter is limited to 25' maximum. Additionally, any altering of the cable length, shortening or lengthening, after the paired unit has been calibrated, will void the calibration as the unit must be calibrated with the cable as a set.

Connections to the sensor must be made with cable supplied by McCrometer specifically for that purpose. Do not substitute the supplied cable with other types of cable, even for short runs. For repairs or added lengths of cable, the entire cable between the sensor and the register must be replaced. (Consult factory for replacement cable.)

STEP 7: Disconnect external wiring connections

The FlowCom digital register must be completely disconnected from any external connections.

This includes:

- SCADA
- Power supply
- Grounding

- NOTE**
- If the old FlowCom unit is going to be used elsewhere, the ground wire and 4-20mA cable can be disconnected from the SCADA unit and the earth ground.
 - If the old FlowCom unit is not going to be used, the 4-20 cable can be cut to facilitate the FlowCom's removal.

The 4-20mA cable connection inside the flowCom unit does not need to be unplugged if it is going to be re-used. If unplugging the cable is desired, the image at right shows where the terminal block plugs into the circuit board.

The old FlowCom unit must be entirely disconnected before proceeding to the next step.

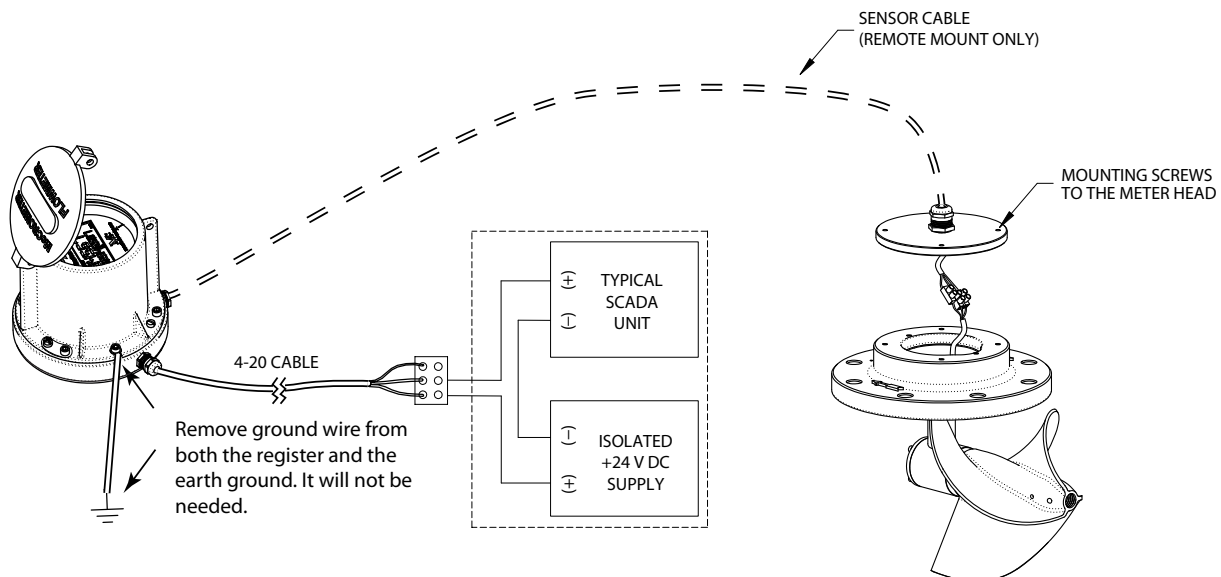

4.3 Old FlowCom to New FlowCom Conversion - Remote Mount (cont.)

STEP 4: Remove the flow meter



WARNING! Never remove a meter or top plate assembly while the line is under pressure!

Remove pressure from the pipeline.

Remove the entire flowmeter from the pipeline.

STEP 3: Remove the meter head plate and the submergible remote mount kit

- a. Remove the four screws from the meter head top plate and lift it from the meter head.
- b. Disconnect the sensor cables from the in-line connectors. There are three wires and three in-line connectors. Do not re-use the in-line connectors.
- a. Unscrew and remove the submergible remote mount kit from the meter head.

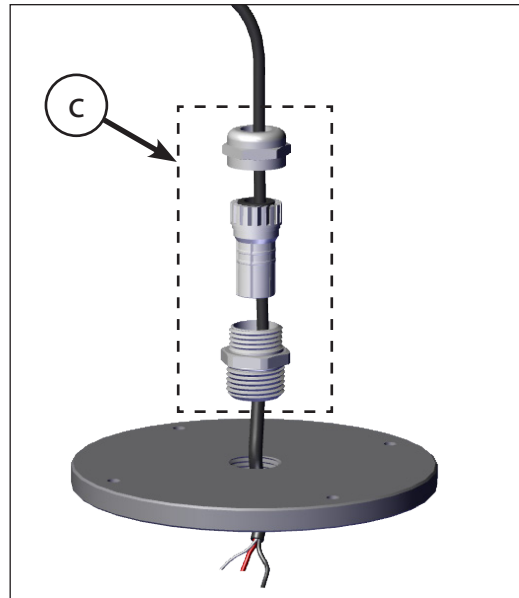
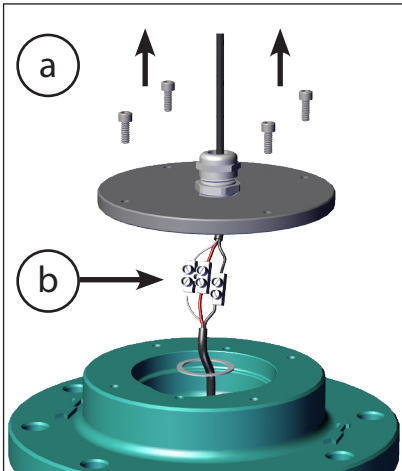

STEP 2: Connect the wiring and attach the meter head plate

- a. Feed the remote mount cable through these items in this order:
 1. The hex bushing cap
 2. The compression gland
 3. The hex bushing
 4. The base plate
 5. The O-ring



- a. Connect the cable to the sensor cable using the in-line terminal blocks. There will be four wires and two in-line connectors.

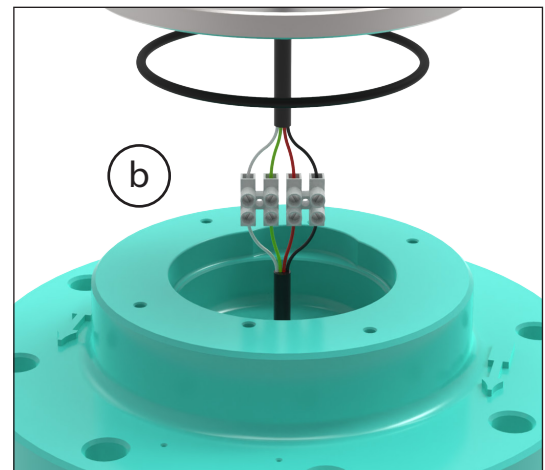

4.3 Old FlowCom to New FlowCom Conversion - Remote Mount (cont.)

- a. Push the compression gland into the hex bushing, making sure the cable is snug in the gland.
- b. Screw the hex bushing into the base plate.
- c. Screw the cap to the hex bushing.

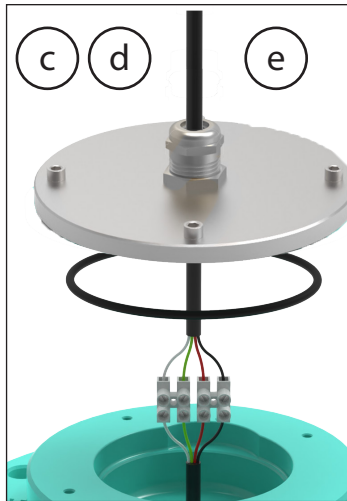

- a. Attach the base plate using four screws. Note: Ensure the O-ring is properly in place.

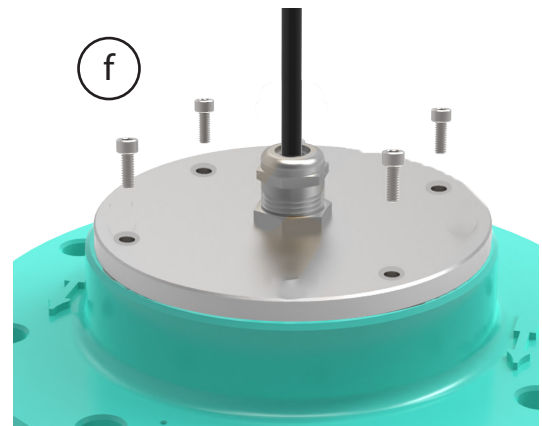

WARNING! Over tightening the cable compression seal will damage the internal conductors, causing them to be crushed and shorted together, preventing proper operation.

STEP 5: Extend the remote mount FlowCom cable run

As mentioned in STEP 1, you need to have your cable run planned out in advance before proceeding. If you are going to use a different path for your cable run, it must be limited to 100' maximum distance.

I IMPORTANT: Do not cut or alter the cable length on power or signal cables!

The cable between the sensor and the transmitter is limited to 100' maximum. Additionally, any altering of the cable length, shortening or lengthening, after the paired unit has been calibrated, will void the calibration as the unit must be calibrated with the cable as a set.

Connections to the sensor must be made with cable supplied by McCrometer specifically for that purpose. Do not substitute the supplied cable with other types of cable, even for short runs. For repairs or added lengths of cable, the entire cable between the sensor and the register must be replaced. (Consult factory for replacement cable.)

4.3 Old FlowCom to New FlowCom Conversion - Remote Mount (cont.)

- a. Attach the FlowCom unit to the remote mount platform with four screws.

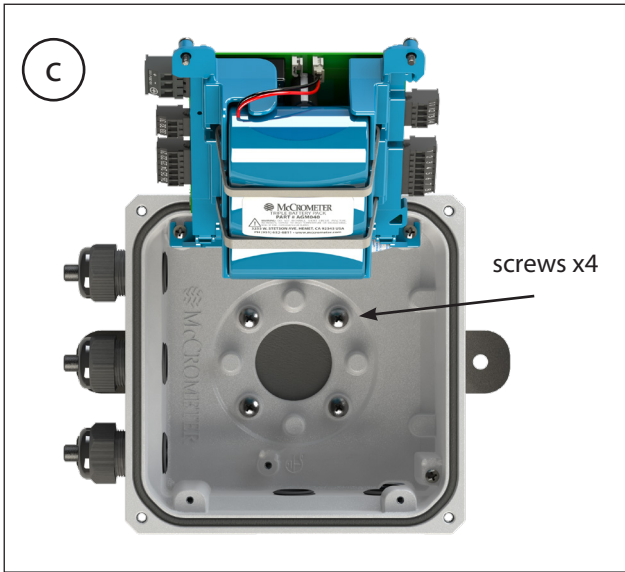

- a. Unscrew the left/middle/right cable gland on the front of the FlowCom unit.
- b. Feed the cable through the cable port nut and gland.
- c. Feed the cable from the flow meter through the open cable port.

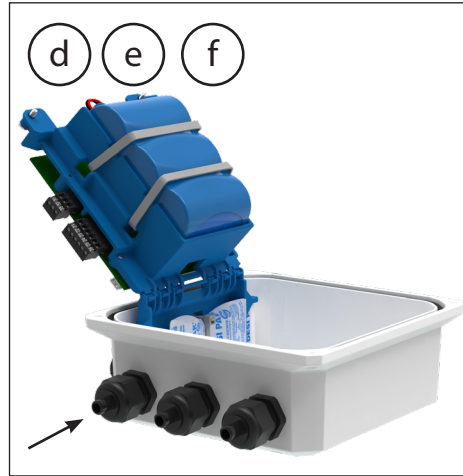

- a. Connect the cable to the terminal block matching the the red, black, green, and white wires.

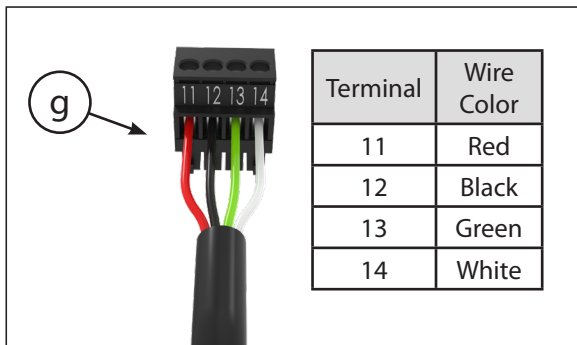

- a. Set the battery tray in place and secure with two screws.
- b. Connect the terminal block to the junction at the rear.

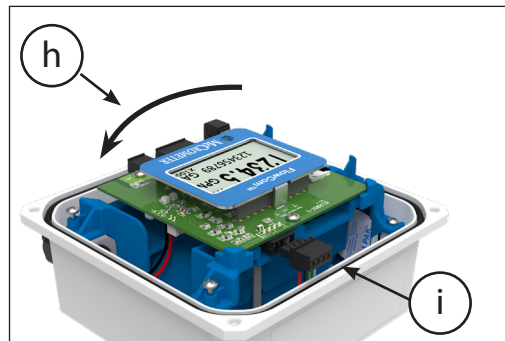

- a. Secure the cover.

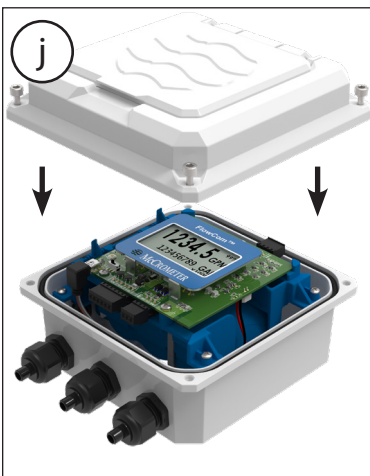

- a. Guide the wire for the tamper-proof seal through the hole in the screw.
- b. Thread the wire through the body of the tamper proof seal.

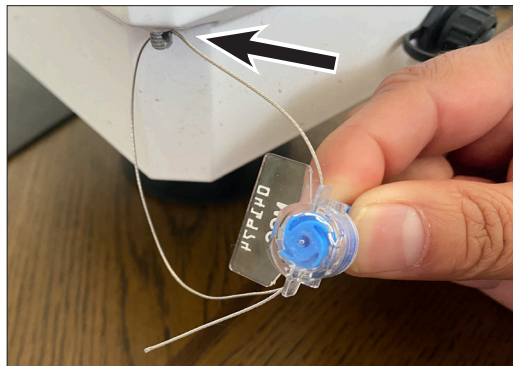

- a. Rotate the blue part on the tamper proof seal to bring in the wire and secure the seal close to the screw.



5.0 INTERNAL WIRE CONNECTION

This section describes cable and wire harness connection inside the register. Section 7.0 describes wire connection for all peripherals outside of the register, including pulse output and external power options.

4.4 Terminal Block Diagram and Grounding Lug

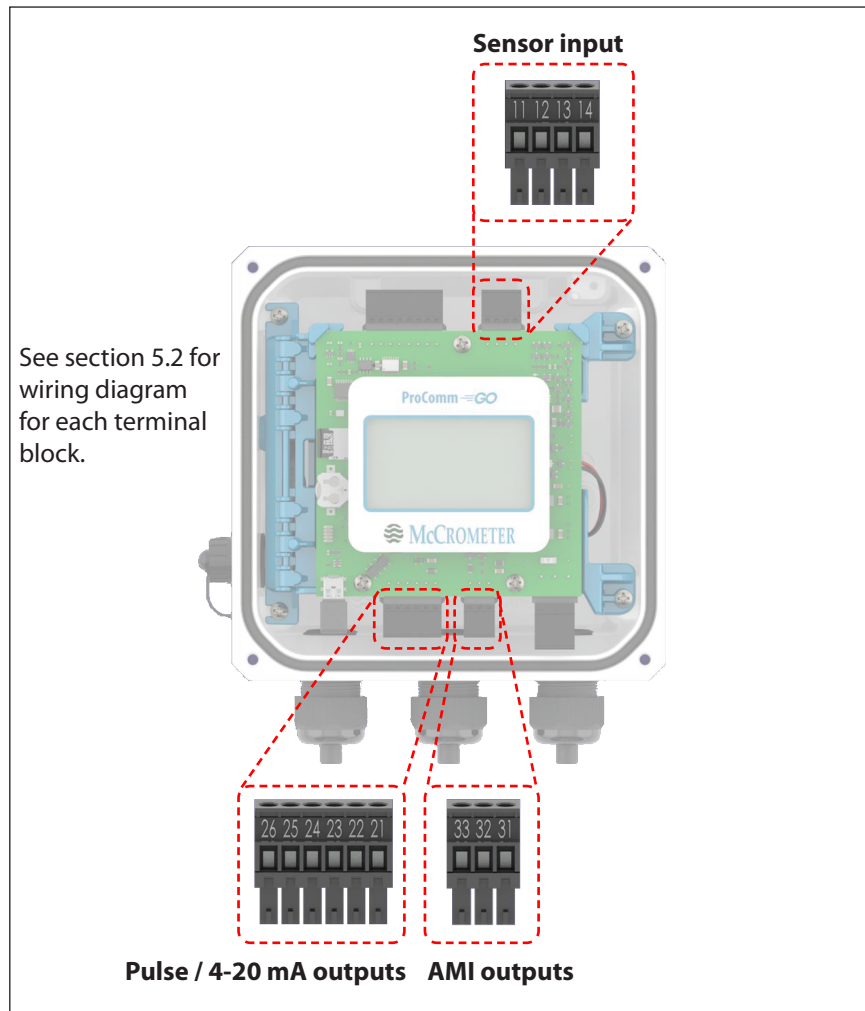
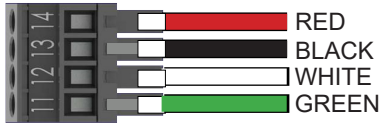

Figure 9. Terminal blocks

5.1 Wiring Diagrams

TERMINAL BLOCK ASSIGNMENTS

Sensor Input



Terminal	Port	Wire Color
11	4	Green
12	4	White
13	4	Black
14	4	Red

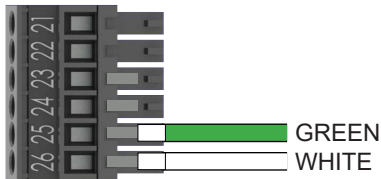

Pulse Output Harness

Terminal	Port	Wire Color
23	1	
24	1	
25	1	Green
26	1	White

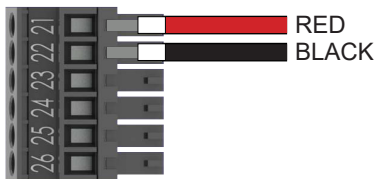

4-20 mA Output Harness

Terminal	Port	Wire Color
21	1	Red
22	1	Black

5.2 Optional Smart Output Hook Up

The convertor comes pre-wired with an interconnection that should readily connect to most AMI transceivers. Where interconnective devices are not mechanically compatible or where non-standard wiring is encountered, the installer can opt to remove the connector from the end of the register's interface cable and make direct connection via the wiring table shown at right. (Figure 10)

- Signals and associated wire colors in the McCrometer SmartOutput™ interface cable are identified together in the top row of the table at right.
- Corresponding wire colors for transceivers from each compatible AMI vendor are identified in the columns under the top row.

McCrometer AMR Interface Pinout

	31 Ground	32 Power/Clock	33 Data
Badger	Black	Red	Green
Elster	Black	Green	Red
Itron	Green	Black	Red
Neptune	Green	Black	Red
Sensus	Black	Red	Green
SmartTrax	Blue	White	Black

Figure 11. AMI interface pinout

5.3 Connecting the SmartTrax Remote Transmitting Unit

For more detail on the SmartTrax transmitter, including specifications, installation requirements, location, and remote data access, see the SmartTrax Installation, Operation, and Maintenance manual, 30125-82.

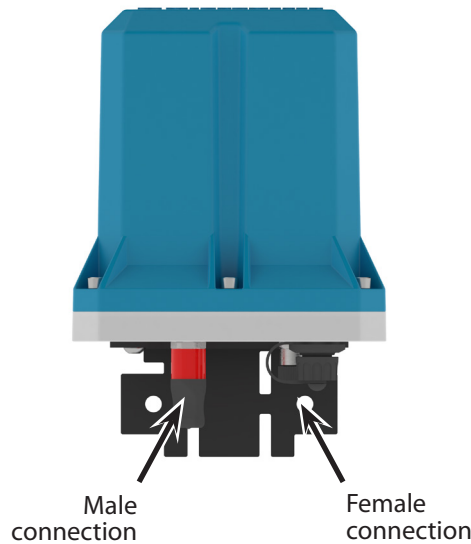

Figure 10. Connections, front view

5.4 FlowCom with SmartTrax On Board

The FlowCom can be configured with a remote SmartTrax unit (see pages page 17 to page 19), but it is also available with built-in SmartTrax, called SmartTrax On Board. It is available for both meter mount or remote mount. An example is shown in Figure 16.

There are no user configurable controls for the for either version of the SmartTrax. See 6.0 for retrieving flow data from the SmartTrax.



Figure 11. Remote mount FlowCom with SmartTrax On Board

6.0 ACCESSING THE SMARTTRAX DATA

This information applies to both FlowCom with the external SmartTrax unit and to FlowCom with SmartTrax on board. For both FlowCom models, there are no external user controls on the SmartTrax. The user interface is through either a laptop or a phone. Before users can view the flow data, they must create an account and log into the data server used for SmartTrax flow data. When that is done, users can add their devices and configure their measurement and output data.

Step 1: Create account

1. Install antenna included with your FlowCom Telemetry unit
2. Use the QR Code on the informational card to access data.mccrometer.com. Sign in or create an account if you haven't done so.
3. Enter your email address, then click on "Send Verification Code".

4. Sign-in to your email to verify your account.
While you're creating your account, you'll get an email from Microsoft on behalf of McCrometer. Open the email and find the verification code.

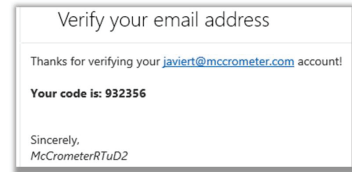
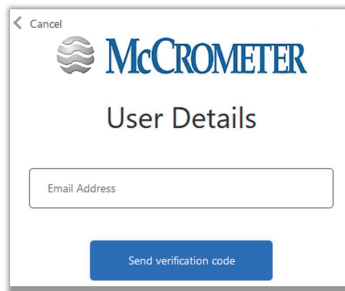

5. To finish creating your account, enter the verification code and click on "Verify Code".

6. Enter "New Password", Re-enter password, "Confirm New Password", enter preferred "Display Name" as it will show on the website and Click "Create".

7. Log-in to your account
 - 7a. Use the following link: <https://data.mccrometer.com>
 - 7b. Enter your email address & Password and click on "Sign in".

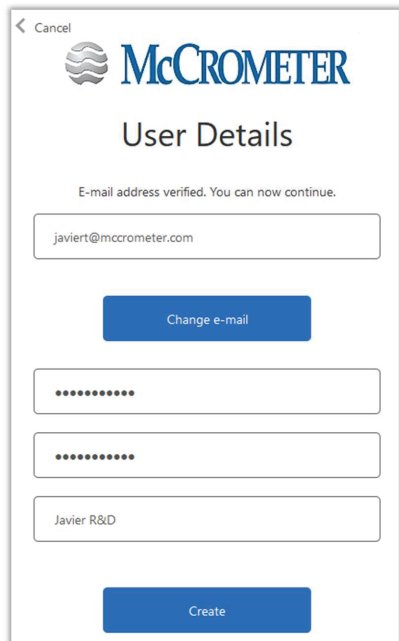

STEP 6: Add SMARTTRAX Unit

1. Click on "Add Device".

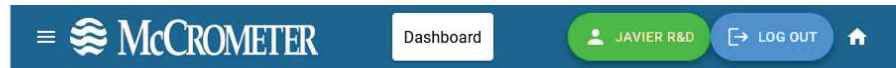

1. Enter "SIM Id", "IMEI" and "Device Serial Number" provided on the informational card with device. If information is lost, please contact customer service.

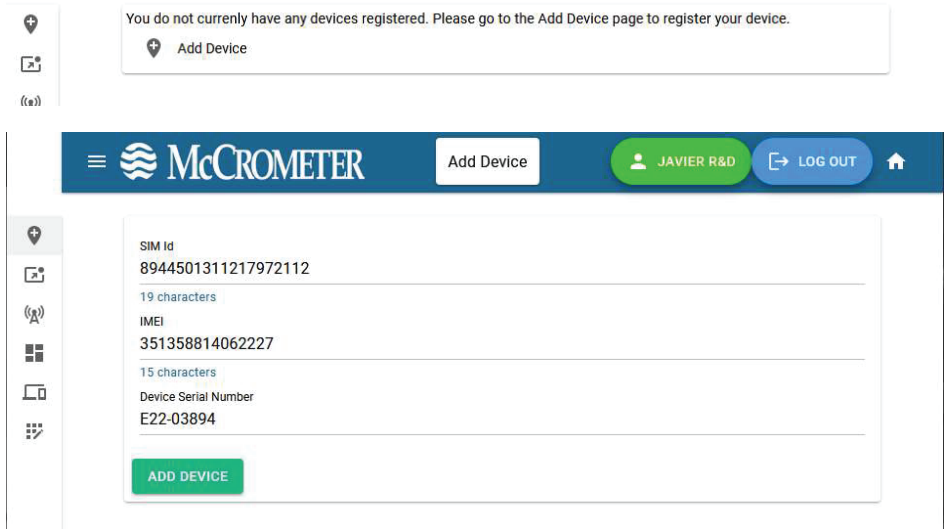

2. Click on "ADD DEVICE"

1. Click on "TAKE OWNERSHIP" if you will be responsible for reoccurring data fees. Each device has a 30-day grace period following activation. Ownership can be transferred via the website anytime.

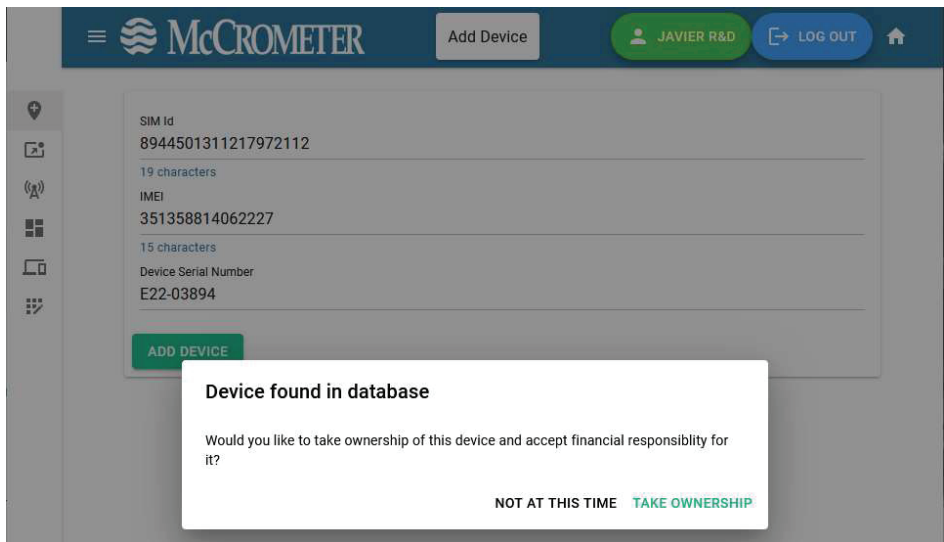

1. Click on "CONFIGURE" to set-up and activate device.

Note: Device configuration can be re-entered or changed anytime on the settings menu of your device.

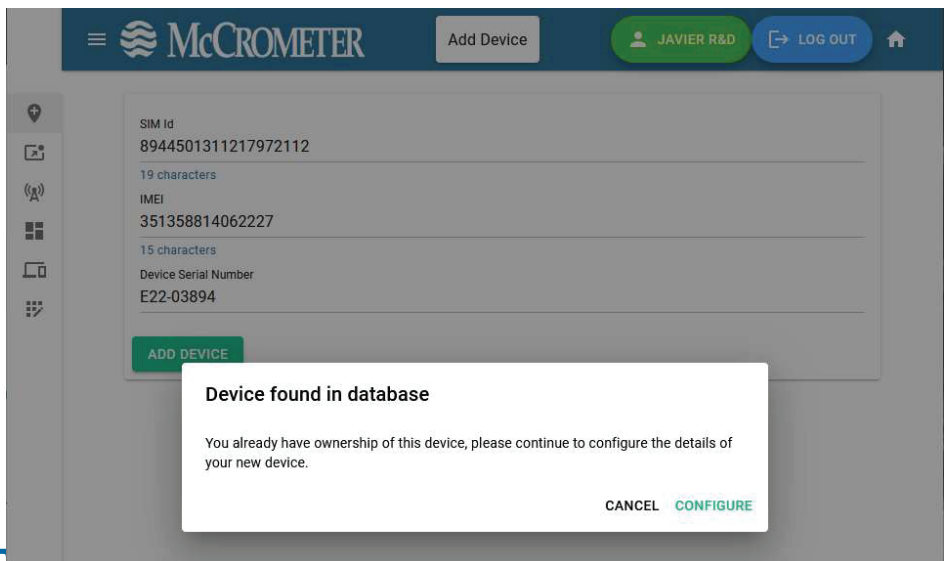

- Make changes to Configuration as needed and click on "DONE" to return to Dashboard.

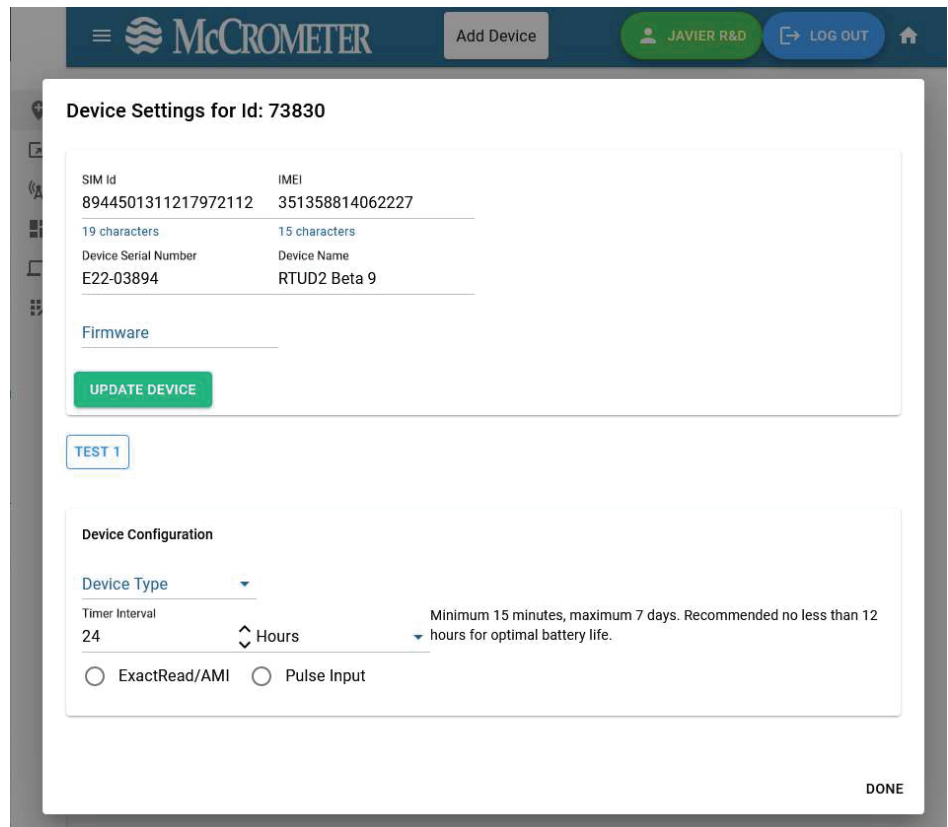

Device Settings for Id: 73830

SIM Id	IMEI
8944501311217972112	351358814062227
19 characters	15 characters
Device Serial Number	Device Name
E22-03894	RTUD2 Beta 9

Firmware

UPDATE DEVICE

TEST 1

Device Configuration

Device Type

Timer Interval: 24 Hours. Minimum 15 minutes, maximum 7 days. Recommended no less than 12 hours for optimal battery life.

ExactRead/AMI Pulse Input

DONE

- Unit has been added to your Account successfully.

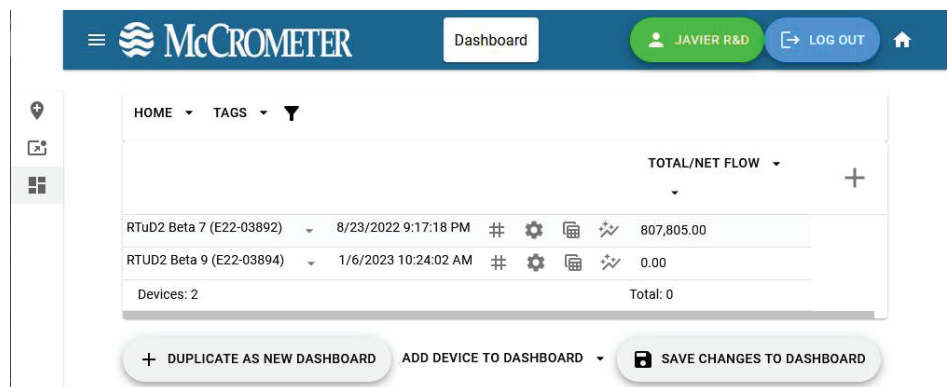

Dashboard

HOME TAGS

				TOTAL/NET FLOW	+
RTUD2 Beta 7 (E22-03892)	8/23/2022 9:17:18 PM	#	⚙️	807,805.00	
RTUD2 Beta 9 (E22-03894)	1/6/2023 10:24:02 AM	#	⚙️	0.00	
Devices: 2				Total:	0

DUPLICATE AS NEW DASHBOARD **ADD DEVICE TO DASHBOARD** **SAVE CHANGES TO DASHBOARD**

7.0 EXTERNAL WIRE CONNECTION

7.1 Cable Gland Connections

The flow meter has one dedicated port and two optional ports on the back side of the electronics enclosure. (Figure 15) The dedicated port (center) is used to download data logger information or for meter service and troubleshooting. The two optional ports are for:

1. Optional 4-20mA output
2. Optional pulse outputs (flow volume and alarms)
3. AMI output

The flow meter is configured at the factory for the optional outputs and requested by the customer at the time of order.



Figure 12. Standard cable gland

6.1 Pulse / 4-20 mA Outputs

The cable contains wiring for both the pulse output and the 4-20mA output from the meter. (Figure 18)

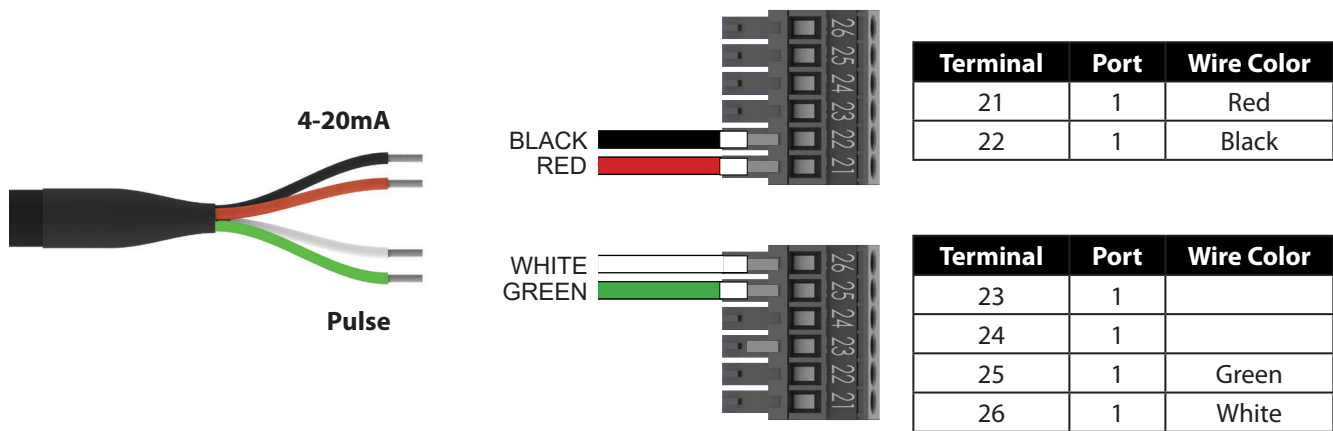

Figure 13. Pulse / 4-20mA Cable Harness

7.2 4-20mA Current Loop

Output type: 4-20mA current loop (Figure 19)

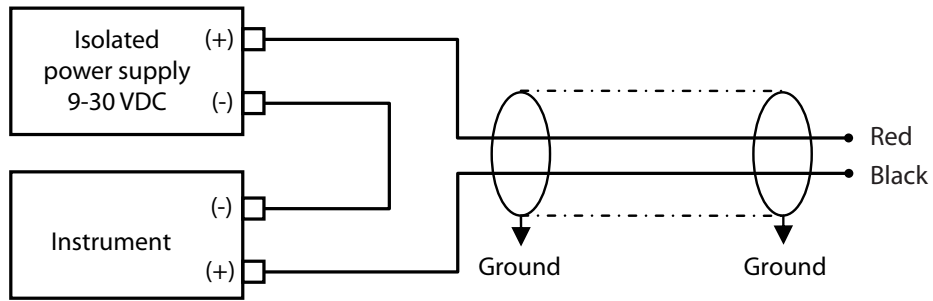



Figure 14. 4-20mA current loop

8.0 BATTERY INSTALLATION AND REPLACEMENT

Materials Provided (shown in order of use)

One triple D battery pack



Replacement cover gasket



Molykote lubricant



Zip ties:
• 2 large



Dry pack



Tamper proof wire seal

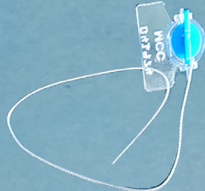

Tool Required

- Wire cutters
- Phillips screwdriver
- 5/32" Allen driver



I. Removing the cover

1. Cut off the tamper-proof seal and remove the wire from the security screw.
NOTE: This step is not required for battery installation in new meters.
2. Remove screws holding the lid to the housing using a 5/32" Allen driver. Lift the lid up and place the lid upside hanging by the green ground wire.

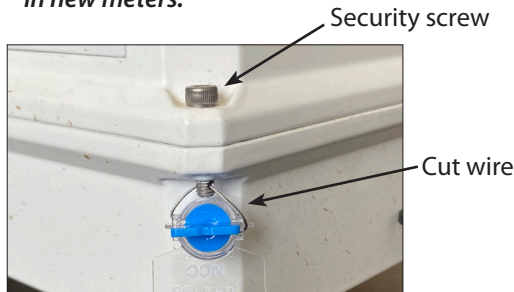

If you are replacing batteries with fresh batteries, continue to step 3.

If you are installing batteries in a new meter that does not have batteries already installed, go to step 9.

II. Removing the batteries

- 3. Unplug tall connectors to sensor, outputs, and power.

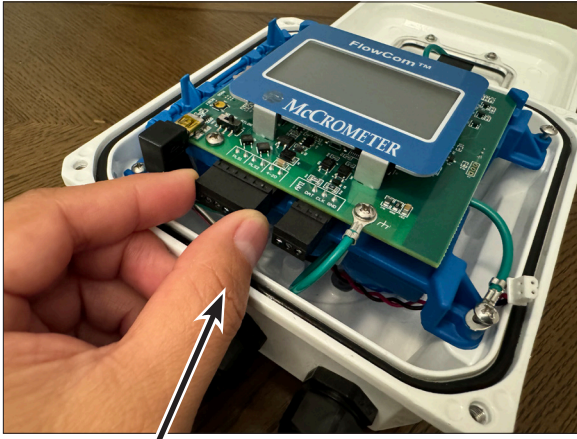

Connectors

- 4. Loosen the captive screws opposite of the hinge and lift the battery cover.

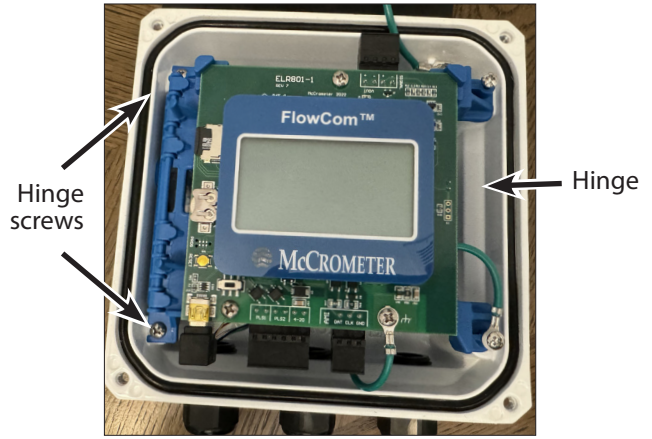

- 5. Unplug the batteries.

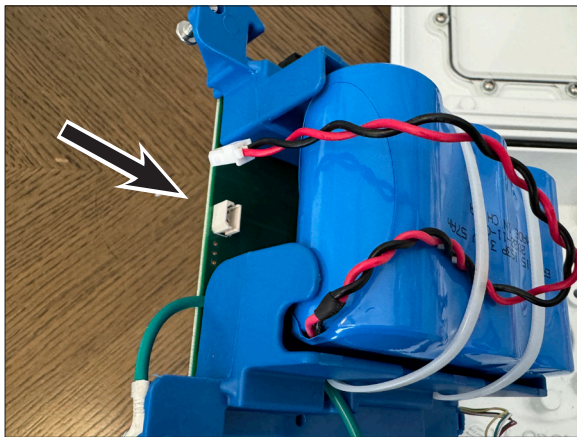

- 6. Cut the two zip ties securing the batteries.



Zip ties

- 7. Remove the large battery pack.

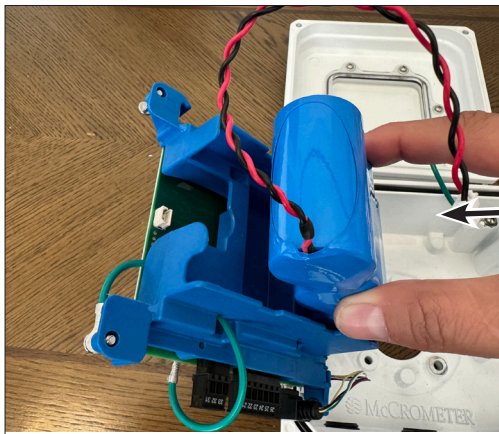

Large battery pack

III. Installing the batteries and restoring the power

8. Cut the zip tie holding the dry pack to the hinge on the converter base.

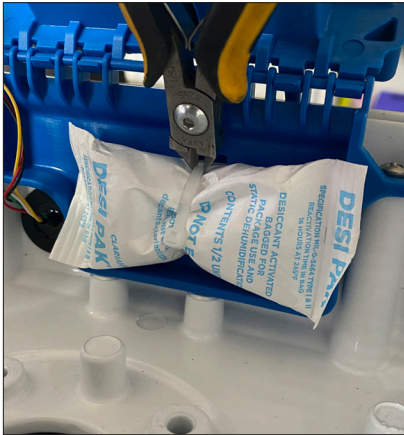

9. Pass the new zip tie through the slots in the internal hinge.

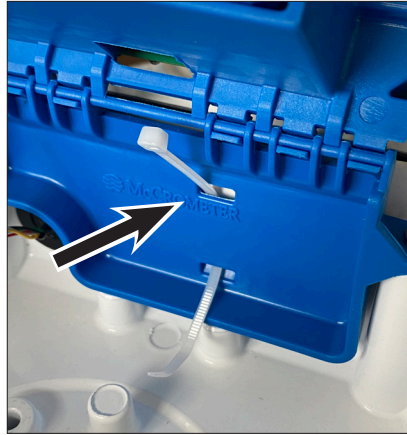

10. Wrap the new zip tie around the new dry pack and cut off the excess.



11. Pass the two large zip ties through the slots in the internal tray holder.

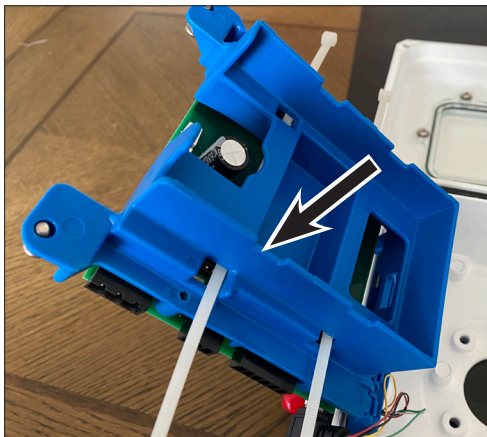

12. Place the large battery pack on the the internal tray with wire leads passing through the slot.

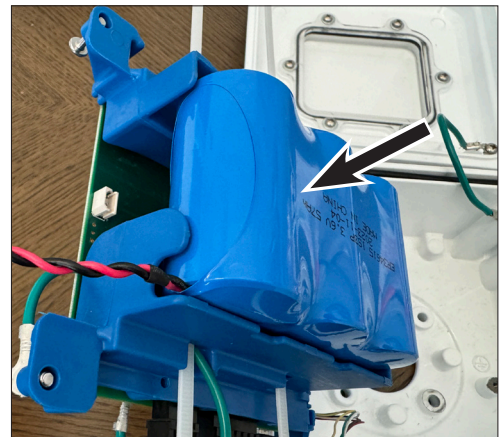

13. Secure the battery packs to the internal tray with the two large zip ties. Cut off the excess of each of the zip ties.



14. Plug the batteries into the circuit board. The large battery pack goes to connector B1.

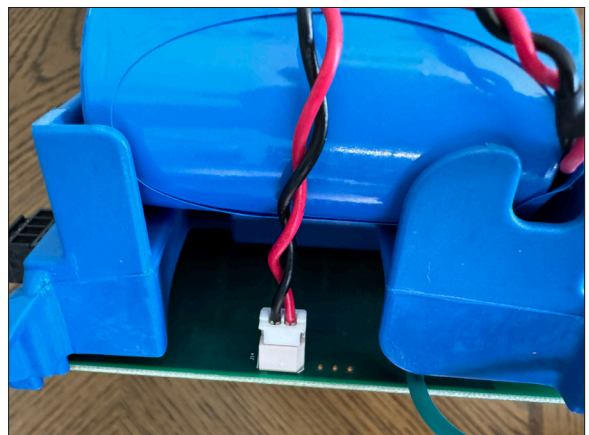

15. Set the hinged LCD/internal battery cover back in place to see the display. The unit will start to power up. Plug in all of the connectors to the board. Ensure that the unit is powered normally and there are no alarms.

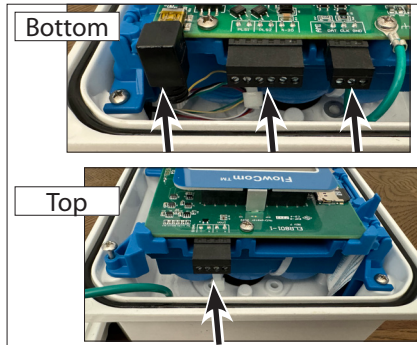
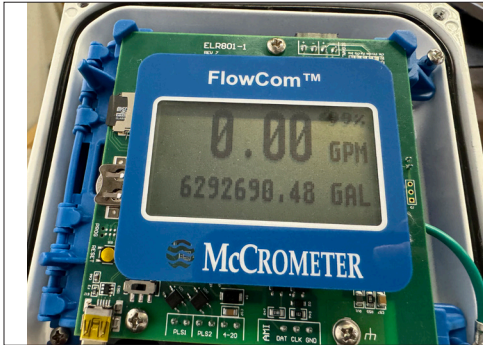

16. Replace the two screws that hold the LCD/battery cover in place.

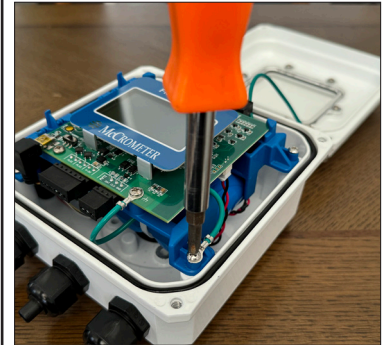

IV. Replacing the gasket

If you installed replacement batteries, we recommend that you replace the gasket.

If you installed new batteries, you must set the gasket in place before replacing the cover and closing up the unit.

17. If your unit has a gasket, remove it.



18. Apply a light coating of Molykote to the replacement gasket.

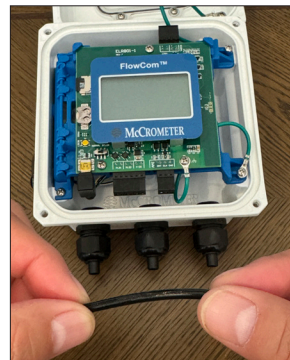

19. Place the gasket in the groove and press it in.



V. Replacing the cover

20. Place the converter lid onto the housing. Tighten the screws firmly. Be careful not to pinch any wires between the lid and the base.



21. Fasten the tamper proof seal as follows:
 a. Guide the wire through the hole in the screw.
 b. Thread the wire through the body of the tamper proof seal.

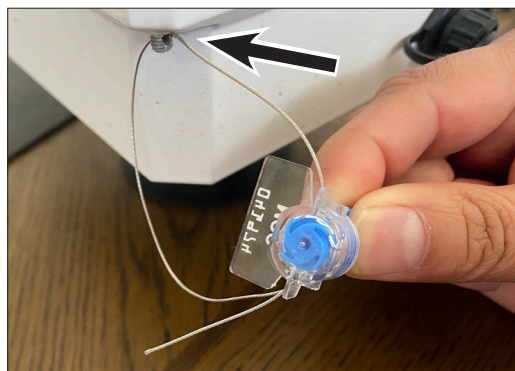

24. Rotate the blue part on the tamper proof seal to bring in the wire and secure the seal close to the screw.

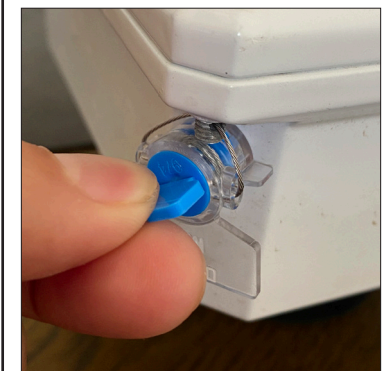

9.0 OPERATION

9.1 General

The flow meter comes pre-configured from the factory based on the installation parameters provided to McCrometer at the time of order. Other than activating the display, there is nothing required of the user for the basic operation of the flow meter.

9.2 Activating the Display

The display is activated when the lid is opened. (Figure 21) The display will remain active for 30 seconds.

The register display is light activated and requires a minimum amount of light to appear. Environments where light is low, such as in dimly lit buildings or outdoors after sundown may prevent the display from appearing when the lid is raised.



Figure 15. Lift lid to activate display

NOTE There is an optical sensor embedded in the display located under the McCrometer “swirl” logo at the lower left. If the display does not appear, a flashlight will provide sufficient light to bring it up.

I CAUTION: If the lid is broken off, contact the Factory for a lid replacement kit. In the meantime, set the lid on the meter in its proper position and use the boot to hold it in place.

The various parts of the interface screen is shown below. (Figure 22) Depending on how the register is configured with the configuration tool (see section 10.0) the display will show either single direction or bidirectional total flow quantities. Bidirectional flows are represented as either positive (POS) or negative (NEG), as shown at right.

NOTE The default setting for the FlowCom register is the positive totalizer. This is done so that any negative flow will be set to 0 and not recorded. Bidirectional flow has to be turned on with either negative or net showing for the register to show a negative flow rate and calculate a negative total.

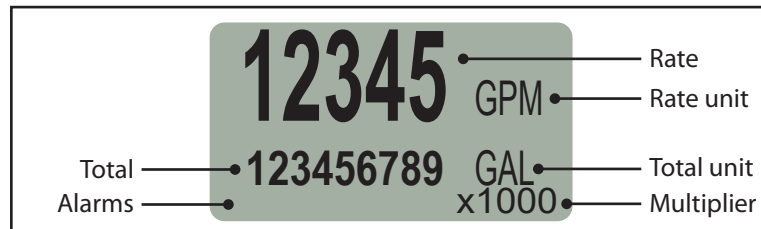

Figure 16. Interface screen

10.1 Register Boot

The boot simply slips over the electronics enclosure. When installing the boot, insure the corners of the boot fit snugly over the lip of the enclosure. See Figure 23. To remove the boot, grip two corners and pull them away from the lip of the enclosure and then pull upwards. See Figure 24.

NOTE It is HIGHLY recommended that register is covered by the boot at all times when the meter is not being read. The boot adds protection to the register.

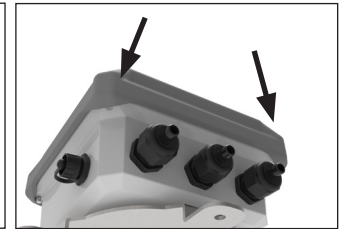
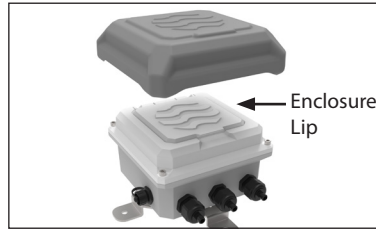

Figure 17. Boot installation **Figure 18. Boot removal**

10.0 REGISTER CONFIGURATION

The register can be programmed to customize how the data is measured and stored. The configuration tool runs only on Windows 7, 8, or 10 and requires a computer with a USB port.

To access the register's USB port, unscrew the cap at the left side of the register. You will need a cable with a mini USB type B connector. (Figure 25)

You must have your flow meter's serial number before you begin. There are no installation files. The program and support files can be copied or unzipped into a folder and run from there.

This is only a summary of the configuration tool's functionality. The software has complete set-up and operation instructions included. The software can be downloaded from the McCrometer Web site.

Software Operation

1. Remove the cap that protects the USB port and plug in a mini USB type B cable. (Figure 26) Connect the other end to a laptop computer.
2. Start the software. Follow the instructions shown before setting up your customized configuration. (Figure 27)
3. When you have set up your configuration file, you can change the settings listed below. Using the configuration tool is mostly self-explanatory.
 - Flow rate unit of measure
 - Totalizer unit of measure
 - Multiplier
 - Totalizer presets
 - Forward/reverse pulse enable: 1 pulse per x per unit of measure
 - Pipe ID
 - Clock time and date
 - Pulse output
 - Automated meter reading

When configuration is complete, remove the USB connector and replace the protective cap.

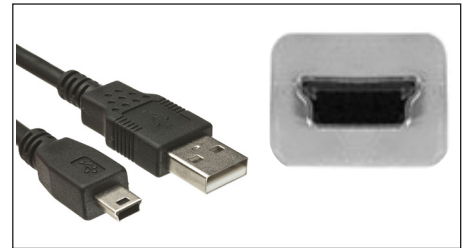

Figure 19. Mini USB type B connector



Figure 20. Plug in mini-USB cable

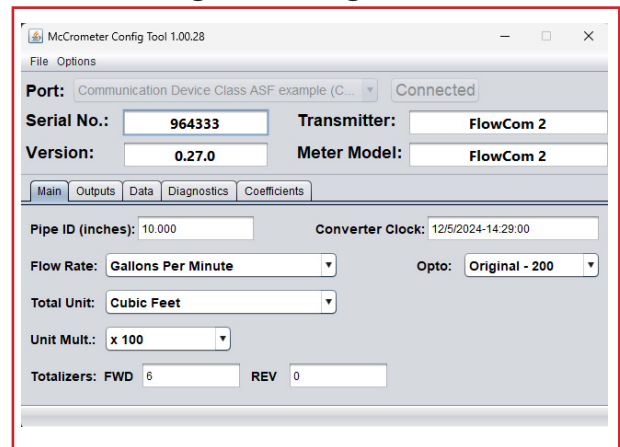

Figure 21. Configuration tool interface

12.0 SPECIFICATIONS

Physical Specifications

Electronic Housing	Diecast aluminum, powder coated enclosure w/ tamper resistant seal, 6½" x 6½" x 43/8" tall
Digital register Dimensions	See "Dimensions" section for meter mount and remote mount digital register dimensions.
Power	Battery: Standard: three 3.6V lithium-thionyl chloride (Li-SOCI2) D size batteries
Electrical Connections	Shielded cable for pulse out

Performance and Operational Specifications

Battery Life	Five-year expected battery life, five-year battery warranty
Location	Indoor or outdoor use
Altitude	Operating: 2000 meters Storage: 12,000 meters
Operating Temperature	-4° to 140° F (-20° to 60° C)
Storage Temperature	-4° to 140° F (-20° to 60° C)
Relative Humidity	0% to 100%
IP Rating	IP67 Die cast aluminum digital register
Outputs	<p>Digital output: Digital pulse (open collector) output for volumetric</p> <ul style="list-style-type: none"> - Isolated digital pulse (open collector) outputs for volumetric - AMI output <p>Analog output: 4-20mA: Galvanically Isolated, 16 Bit resolution. All power configurations (including battery).</p> <p>Note: 9-30 VDC loop power required (not supplied via digital register)</p>

Display and Measurement

Display	<ul style="list-style-type: none"> • 2-Line LCD display (no backlight) • Non-volatile memory • Anti-reverse totalizer (standard) • Total (to 9 digits of precision) 	<ul style="list-style-type: none"> • Flow rate and velocity (to 5 digits of precision) • Two alarms: low battery and empty pipe (optional) • Opening lid activates display
Digits	5 Rate, 9 Total	
Units	GPM Gallons per minute MGD Mega gal per day CFS Cubic feet per second MLD Megaliters per day LPS Liters per second CMH Cubic meters per hour LPM Liters per minute GPH Gallons per hour IGM Imperial gal per minute MI9 Miners inch (9G) MI1 Miners inch (11.22G) APD Acre feet per day	KLH Kiloliters per hour LPH Liters per hour CMM Cubic meters per minute CFM Cubic feet per minute CFM Cubic feet per minute B5M Barrels per minute (55G) B5H Barrels per hour (55G) B5D Barrels per day (55G) B4M Barrels per minute (42G) B4H Barrels per hour (42G) B4D Barrels per day (42G)

Totalizer Units	GAL	Gallons	AIN	Acre Inch
	CUF	Cubic Feet	TON	Ton (Short)
	AFT	Acre Feet	MM1	Miners Inch Minute (11.22G)
	CUM	Cubic Meters	MM9	Miners Inch Minute (9G)
	LIT	Liters	MH1	Miners Inch Hour (11.22G)
	MML	Megaliter	MD1	Miners Inch Day (11.22G)
	MTT	Metric Ton (KL)	MH9	Miners Inch Hour (9G)
	B31	Barrel (31G)	MD9	Miners Inch Day (9G)
	B42	Barrel (42G)	KGL	Kilo Gallons
	B46	Barrel (46G)	MGL	Mega Gallons
	B55	Barrel (55G)	IN3	Cubic Inch
	IMG	Imperial Gallon		
	Data Logger	Standard with all models, minimum of five years of data stored (4gb)		

Other Specifications

Options and Accessories	<ul style="list-style-type: none"> Data Logger - included as standard with five years of data storage at default (12hr) interval. (Cable sold separately)
--------------------------------	--

13.0 DIMENSIONS

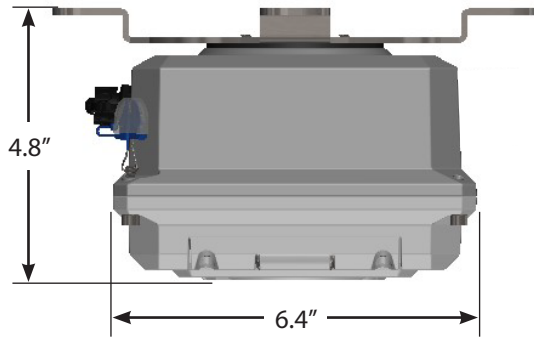
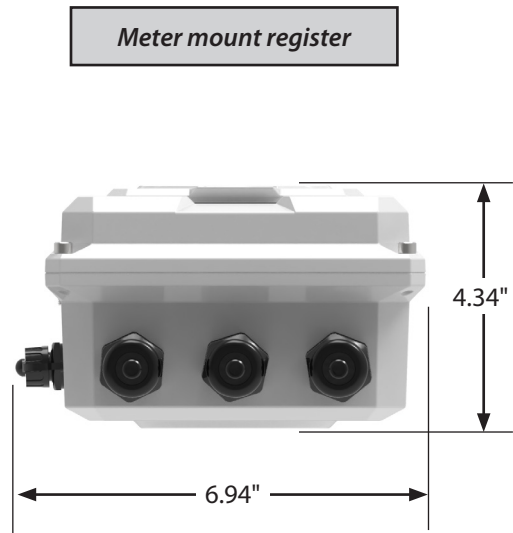
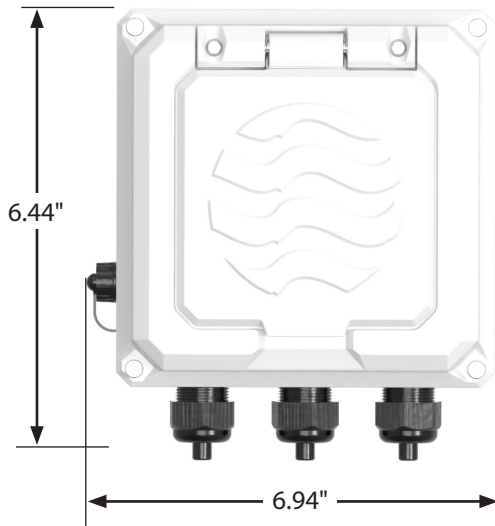

Remote mount register

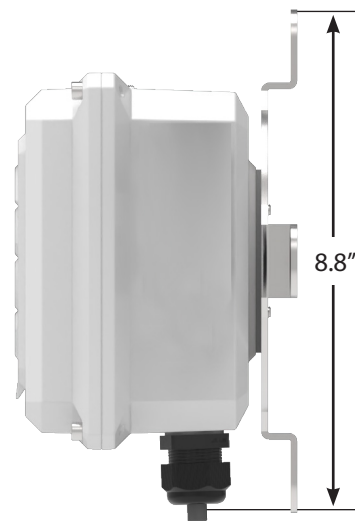
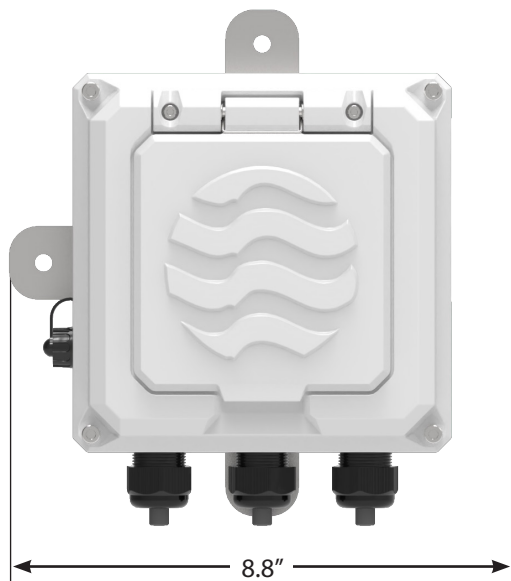

WARRANTY STATEMENT

Manufacturer warrants all products of its manufacture to be free from defects in workmanship and material under normal use and service. This warranty extends for a period of twelve (12) months after date of shipment, unless altered by mutual agreement between the purchaser and manufacturer prior to the shipment of the product. If this product is believed to be defective, purchaser shall notify manufacturer and will return the product to the manufacturer, postage paid, within twelve (12) months after date of shipment by the manufacturer. If the purchaser believes the return of the product to be impractical, manufacturer shall have the option, but will not be required, to inspect the product wherever located. In any event, if the purchaser requests the manufacturer visit their location, the purchaser agrees to pay the non-warranty expenses of travel, lodging and subsistence for the field service response. If the product is found by the manufacturer's inspection to be defective in workmanship or material, the defective part or parts will either be repaired or replaced, at manufacturer's election, free of charge, and if necessary the product will be returned to purchaser, transportation prepaid to any point in the United States. If inspection by the manufacturer of such product does not disclose any defect of workmanship or material, manufacturer's regular service repair charges will apply. Computing devices sold but not manufactured by McCrometer, Inc. are covered only by the original manufacturer's written warranty. Hence, this warranty statement does not apply.

THE FOREGOING WARRANTY IS MANUFACTURER'S SOLE WARRANTY, AND ALL OTHER WARRANTIES, EXPRESS, IMPLIED OR STATUTORY, INCLUDING ANY IMPLIED WARRANTY OF MERCHANTABILITY OR FITNESS FOR A PARTICULAR PURPOSE, ARE NEGATED AND EXCLUDED. THE FOREGOING WARRANTY IS IN LIEU OF ALL OTHER WARRANTIES, GUARANTEES, REPRESENTATIONS, OBLIGATIONS OR LIABILITIES ON THE PART OF THE MANUFACTURER.

Purchaser's sole remedy and manufacturer's sole obligation for alleged product failure, whether under warranty claim or otherwise, shall be the aforesaid obligation of manufacturer to repair or replace products returned within twelve months after date of original shipment. The manufacturer shall not be liable for, and the purchaser assumes and agrees to indemnify and save harmless the manufacturer in respect to, any loss or damage that may arise through the use by the purchaser of any of the manufacturer's products.

If you experience problems with your FlowCom register, please contact your local factory representative for assistance. You may also contact Customer Service at the factory directly at 951-652-6811. Be prepared to provide the serial number off of your meter or FlowCom register (this information is located on the lid of the register).

When returning McCrometer products to the factory for repair or warranty consideration, a return authorization number (RA) must be obtained from the factory and referenced on the outside of the box of the products you are returning. The products should be shipped back to the factory at:

McCrometer
3255 West Stetson Avenue
Hemet CA 92545