

# ProComm Max Electromagnetic Flow Meter Transmitter

## Installation, Operation and Maintenance Manual



### Standard Model

For use in non-hazardous locations

### HL Model

For use in hazardous locations:

- Class I, Division 2, Groups A B C D, T4
- Class I, Zone 2 IIC T4

30126-48 Rev. 1.4  
15DEC2025



# Contents

<b>1.0</b>	<b>TRANSMITTER DESCRIPTION</b>	<b>2</b>
<b>2.0</b>	<b>INSTALLING THE TRANSMITTER AND CABLES</b>	<b>2</b>
2.1	Finding the Transmitter's Serial Number	2
2.2	Example Remote Mount Configuration	3
2.3	Mounting the Transmitter	3
2.4	Installing Cables through Cable Glands and Conduit	4
2.5	Cable Gland Assignment for Wiring Harnesses	5
2.6	Pulling Sensor Cable Through Electrical Conduit	6
<b>3.0</b>	<b>CABLING AND CONNECTING WIRING</b>	<b>7</b>
3.0.1	Remote Mount Cable Connection to Sensor	7
3.0.2	Terminal Block Diagram	7
3.1	Wiring Diagrams	8
3.2	Installing Expansion Cards	9
3.3	Transmitter Power Wiring Diagram	10
3.4	4-20mA Hook-Up	11
3.5	HART Hook-Up	11
3.6	Opto-Isolated Pulse Output Hook-Up	12
3.7	Optional Smart Output Hook Up	12
3.8	Connecting the SmartTrax Remote Transmitting Unit	12
<b>4.0</b>	<b>TRANSMITTER OPERATION</b>	<b>13</b>
4.1	Starting up the Transmitter	13
4.1.1	Menu Navigation	13
4.2	Default Screens While Transmitter Is Operating	14
4.3	Menu Structure	15
4.4	Menu Configuration	16
<b>5.0</b>	<b>ALARM MESSAGES</b>	<b>19</b>
5.1	Firmware Updates	20
<b>6.0</b>	<b>MODBUS PROTOCOL</b>	<b>21</b>
6.1	Hardware Installation and Wiring	21
6.2	Configuration	21
6.3	Communication	22
6.4	MODBUS Register Map	23
<b>7.0</b>	<b>HART PROTOCOL</b>	<b>24</b>
7.1	Hardware Installation and Wiring	21
7.2	Configuration	21
7.3	Communication	22
7.3.1	Settings	22
7.3.2	Commands	22
<b>8.0</b>	<b>ETHERNET/IP PROTOCOL</b>	<b>24</b>
8.1	Hardware Installation and Wiring	27
8.2	Configuration	27
8.3	Communication	27
8.3.1	Ethernet/IP	27
8.3.2	Procomm Max	27
8.3.3	Communication Details	28
8.3.4	Device Parameters	28
8.3.2	Assembly Instances	28
<b>9.0</b>	<b>SPECIFICATIONS</b>	<b>29</b>
<b>10.0</b>	<b>DIMENSIONS</b>	<b>31</b>
<b>11.0</b>	<b>ACCESSORIES AND REPLACEMENT PARTS</b>	<b>33</b>
<b>12.0</b>	<b>RETURNING A UNIT FOR REPAIR</b>	<b>34</b>
	<b>WARRANTY</b>	<b>36</b>

## **SAFETY**

### **Safety Symbols**

Throughout this manual are safety warning and caution information boxes. Each warning and caution box will be identified by a large symbol indicating the type of information contained in the box. The symbols are explained below:

### **Safety Warnings**



This symbol indicates important safety information. Failure to follow the instructions can result in serious injury or death.



This symbol indicates important information. Failure to follow the instructions can result in permanent damage to the meter or installation site.

When installing, operating, and maintaining McCrometer equipment where hazards may be present, you must protect yourself by wearing Personal Protective Equipment (PPE) and be trained to enter confined spaces. Examples of confined spaces are manholes, pumping stations, pipelines, pits, septic tanks, sewage digesters, vaults, degreasers, storage tanks, boilers, and furnaces.



**WARNING!**

**Incorrect installation or removal of FPI Mag meters can result in serious injury or death.** Read the instructions in this manual on the proper procedures carefully.



**WARNING!**

**Never enter a confined space without testing the air at the top, middle, and bottom of the space.** The air may be toxic, oxygen deficient, or explosive. Do not trust your senses to determine if the air is safe. You cannot see or smell many toxic gases.



**WARNING!**

**Never enter a confined space without the proper safety equipment.** You may need a respirator, gas detector, tripod, lifeline, and other safety equipment.



**WARNING!**

**Never enter a confined space without standby/rescue personnel within earshot.** Standby/rescue personnel must know what action to take in case of an emergency.



**WARNING!**

**Pressurized pipes should only be hot tapped, cut, or drilled by qualified personnel. If possible, depressurize and drain the pipe before attempting any installation.**



**WARNING!**

**Carefully read all safety warning tags attached to the meter.**



***At the end of its lifetime, this product shall be disposed of in full compliance with the environmental regulations of the state in which it is located.***

## 1.0 TRANSMITTER DESCRIPTION

Read this entire manual prior to installation and/or changing any settings. Retain this manual in your records, DO NOT DISCARD.

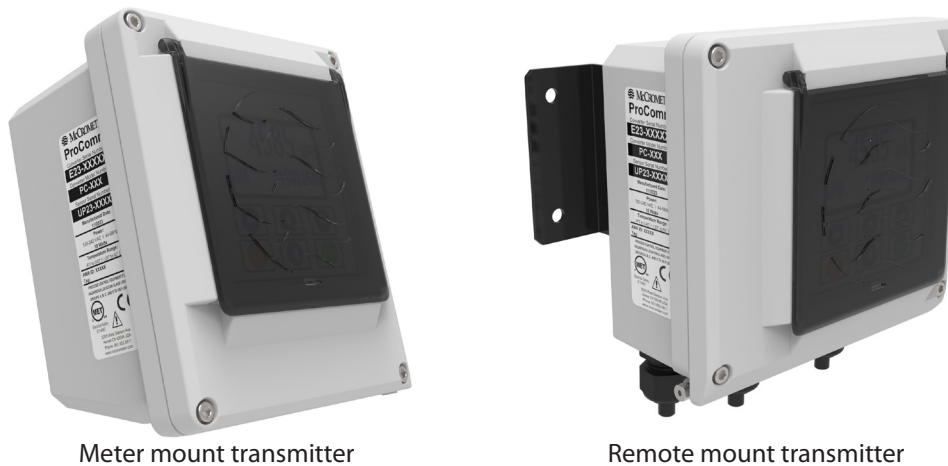
The signal transmitter is the reporting, input and output control device for the sensor. The transmitter allows the measurements, functional programming, control of the sensor and data recording to be communicated through the display and inputs & outputs. The microprocessor-based signal transmitter has a pulse volumetric output, AMI (Sensus, Itron) output, 4-20mA analog output, an 8-line graphical backlit LCD display with six-key touch programming, and a rugged enclosure that meets IP67. Options include daughter cards for HART, ModBus, Ethernet, AC or DC power.

In addition to a menu-driven self-diagnostic test mode, the microprocessor continually monitors the transmitter's functionality. The transmitter will output rate of flow and total volume.

## 2.0 INSTALLING THE TRANSMITTER AND CABLES

### 2.1 Finding the Transmitter's Serial Number

The tag on the side of the transmitter has the transmitter model number and the serial number. An example is shown below as Figure 1.

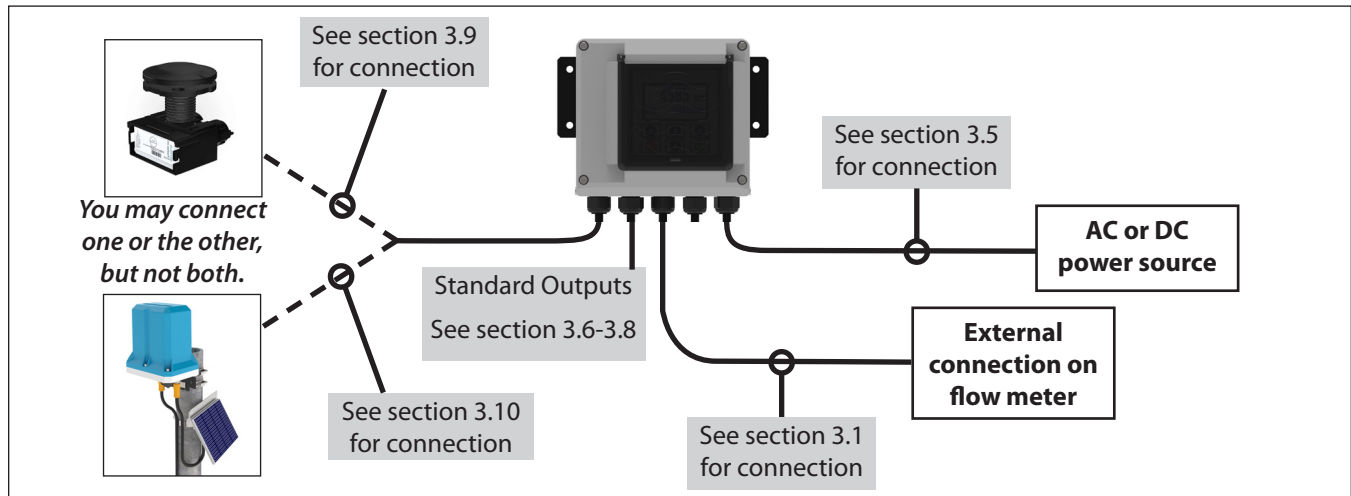


**Figure 1. Location of Transmitter's Serial Number Tag**

## 2.2 Example Remote Mount Configuration

After installing the sensor, mount the transmitter and connect the cable to the meter's junction box and the transmitter's external connection. Figure 2 below shows an example of a remote mount installation with an optional Smart Output connection.

Ensure that the cable from the sensor to the transmitter is of sufficient length. Connect it to the sensor and route the cable in the most appropriate manner. Insert the cable into the bottom of the housing through the gland seal, cut the cable to the desired length and terminate the wires in accordance with the wiring diagram



**I** **IMPORTANT:** The example shown above does not include grounding installation. The meter will need to be grounded according to each meter's requirements.

**Figure 2. Example remote mount configuration**

## 2.3 Mounting the Transmitter

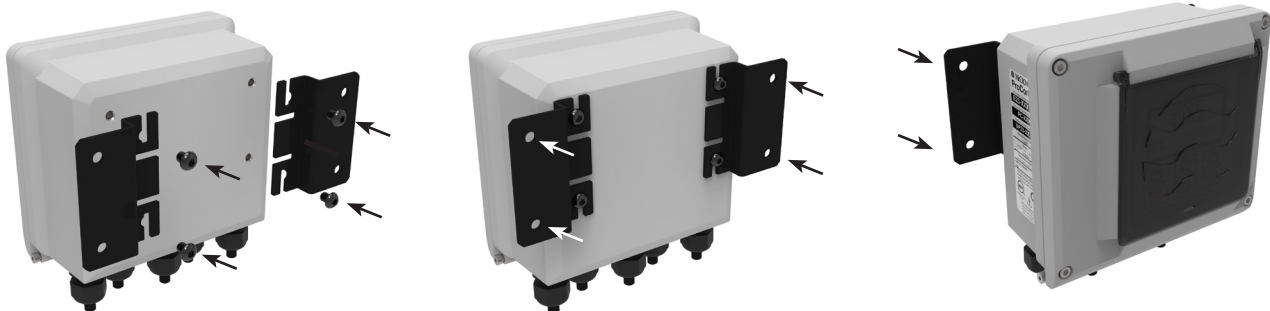
*Note: This applies to the remote mount transmitter only.*

If possible, mount the transmitter in an electronics shed or environmental enclosure. The sun shield should be oriented in a direction to reduce sun damage and ensure readability.

Mount the transmitter to a solid surface using four bolts (Figure 3) or to a vertical or horizontal post using two clamps (Figure 4 and Figure 5). This electronic unit is rated IP67 for temporary flooding.

If the brackets are not attached, attach them with the four screws.

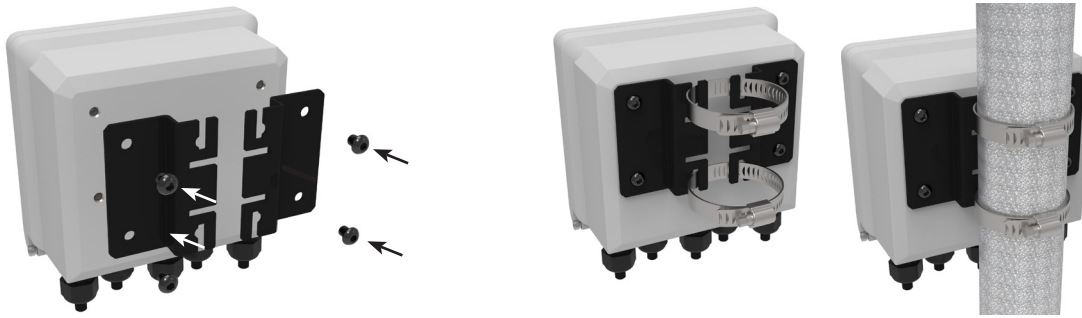
Mount the transmitter to a solid surface with four bolts through the holes in the left and right brackets.



**Figure 3. Mounting transmitter to solid surface**

Remove brackets, reverse them, and reattach as shown.

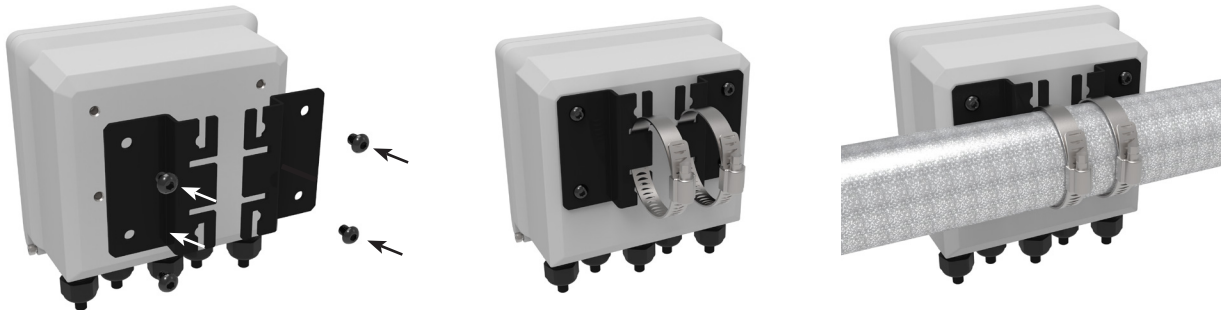
Open clamps and attach around post. Slide bracket tabs onto clamps and tighten them.



**Figure 4. Mounting transmitter to vertical post**

Remove brackets, reverse them, and reattach as shown.

Open clamps and attach around post. Slide bracket tabs onto clamps and tighten them.



**Figure 5. Mounting transmitter to horizontal post**

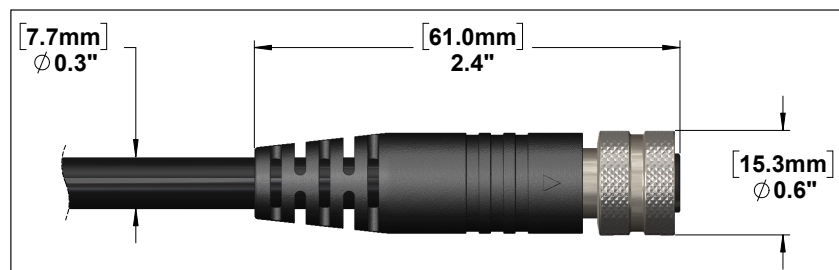
## 2.4 Installing Cables through Cable Glands and Conduit

All electrical cables enter the transmitter through compression fittings or optional customer-supplied conduit located on the side or bottom of the transmitter (Figure 7, Figure 8, Figure 9) . Ensure that all compression glands are properly tightened and all unused fittings are plugged so the case remains sealed.

The power cable and wiring harnesses are each assigned specific cable glands where they will pass through into the transmitter. See section 2.5 for cable gland assignment for wiring harnesses and section 3.3 for wiring diagrams.

All cable compression glands must be properly tightened to prevent moisture intrusion and maintain the IP67 rating. To insure IP67 rating, use only round cable 0.24" to 0.47" in diameter.

If you are using quick connect cables, ensure the conduit is large enough to accommodate the cable connections. See Figure 6 below with the cable connection dimensions.



**Figure 6. Quick connect cable dimensions**



**Figure 7. Remote mount transmitter with five cable gland pass-throughs**



**Figure 8. Remote mount transmitter with three conduit pass-throughs**



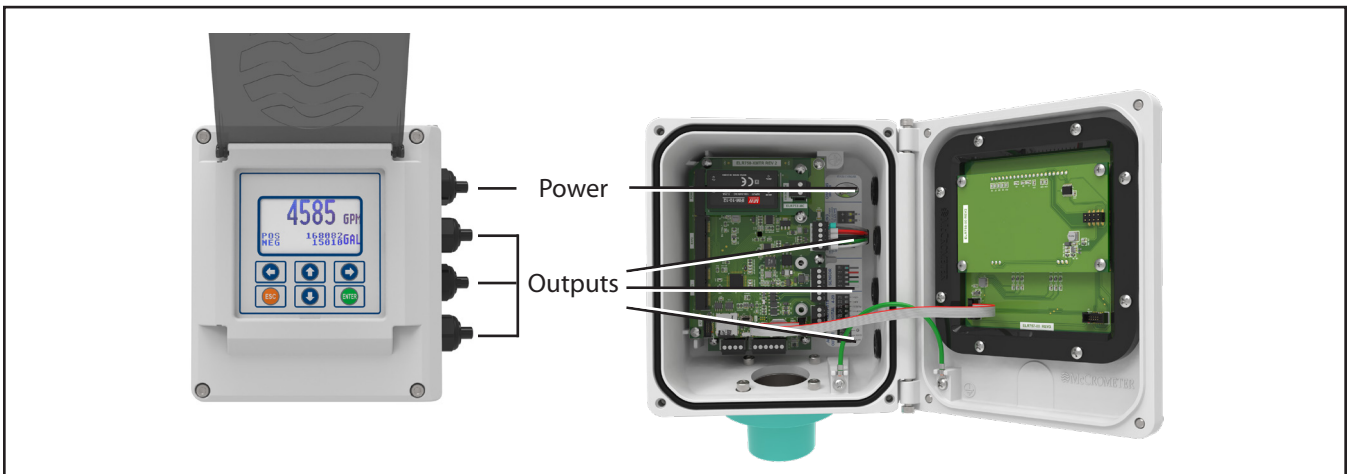
**Figure 9. Meter mount transmitter with four cable gland pass-throughs**



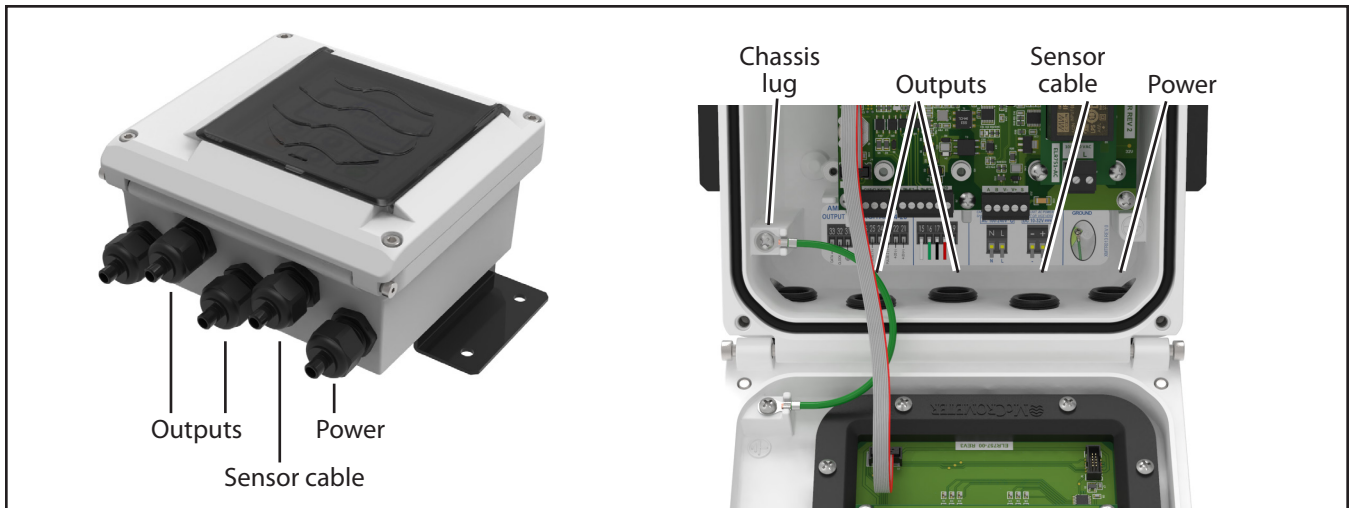
Attaching conduit directly to the enclosure may introduce dangerous gasses and moisture into the enclosure creating a dangerous condition, and will remove the enclosure's IP67 rating. **Damage caused by attaching conduit to the enclosure or altering the enclosure in any way is not covered by the warranty.**

## 2.5 Cable Gland Assignment for Wiring Harnesses

To prevent signal interference and to keep the wiring organized, each cable gland is assigned for a specific wiring harness. Refer to the assignment diagrams (Figure 10, Figure 11) below when you route your cable run.



**Figure 10. Meter mount transmitter cable assignments**



**Figure 11. Remote mount transmitter cable assignments**

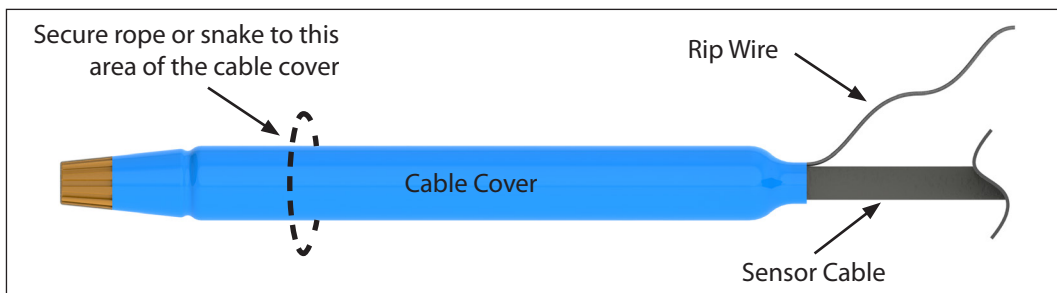
## 2.6 Pulling Sensor Cable Through Electrical Conduit

It is very important to protect the end of the sensor cable when pulling it through a conduit. Water can accumulate in low portions of conduit. Always use a cable cover, or similar method, to seal the end of the cable against water when pulling the cable through conduit (see Figure 12). This will ensure proper operation of the meter.

**NOTE** Cable cover is not provided.

1. Tie a rope or cable-snake securely around the middle of the cable cover.
2. Carefully pull the rope or snake until the sensor cable end clears the conduit.
3. Bring the cable end to the transmitter location. If necessary, secure the cable so that it does not fall back through the conduit.
4. Remove the cable cover by pulling the rip wire. The cable cover will tear off (discard the cover).

**I CAUTION:** Do not cut the cable cover off. Doing so may damage the sensor cable and adversely effect the calibration of the meter.



**Figure 12. Example of a Cable Cover**

### 3.0 CABLING AND CONNECTING WIRING



**WARNING!**

Ensure device is disconnected or circuit breaker is open per the requirements of IEC 60947-1 and IEC 60947-3 before opening the transmitter.

#### 3.0.1 Remote Mount Cable Connection to Sensor

The ProComm Max transmitter is designed to connect to a single-port converter box mounted on meter. See Figure 13 as an example showing the Ultra Mag meter. This design converts flow data and sends it to the ProComm Max transmitter. All calibration data is held in non-volatile memory at the converter. Consequently, cable distances from the converter to the transmitter have no effect on meter calibration. This will allow users to swap transmitters in the field if needed, requiring only the SD card in the transmitter to be moved to the replacement unit.

The port on the converter is available as either a cable gland fitting or a quick connect fitting.

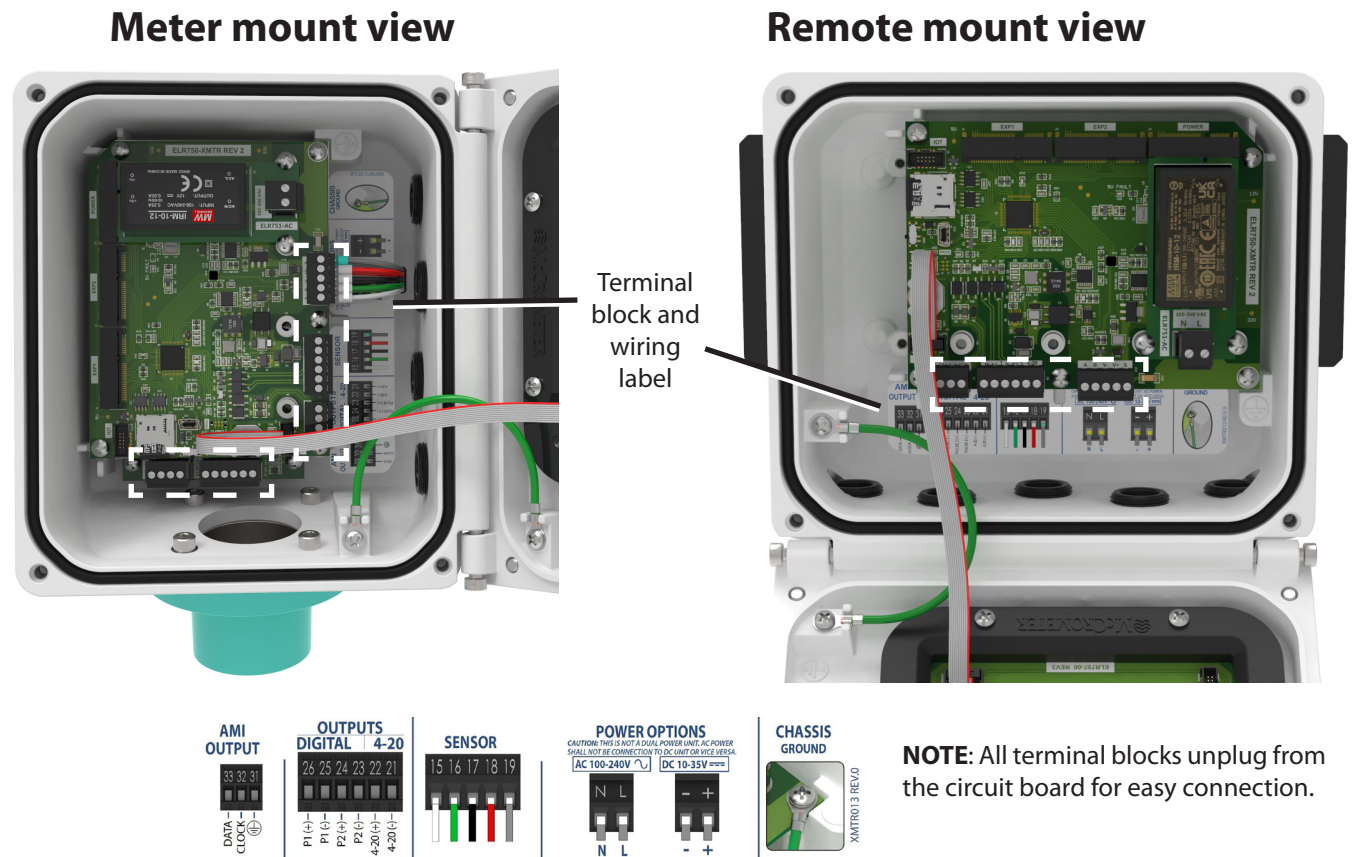


**Figure 13. Converter box mounted on a mag meter**

#### 3.0.2 Terminal Block Diagram

All connections are made on the terminal blocks. To access the terminal blocks, loosen the four captive screws on the front of the transmitter and open the front panel. Refer to Figure 8 and Figure 9. The example shown below (Figure 14) does not necessarily represent all transmitter models, however, it shows the placement for all terminal blocks used in all models.

**NOTE:** The terminal blocks unplug from the circuit board for easy connection.



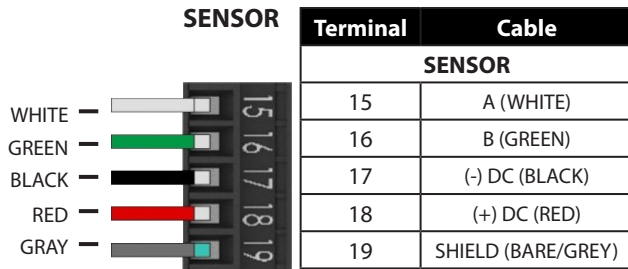
**NOTE:** All terminal blocks unplug from the circuit board for easy connection.

**Figure 14. Terminal Block Diagram**

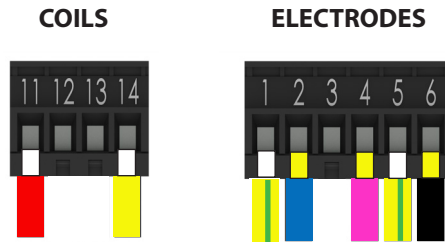
### 3.1 Wiring Diagrams

**CAUTION** - Always disconnect the power cord before attempting any electrical connections.

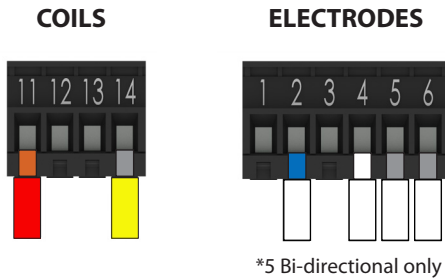
#### Transmitter Wiring Diagram



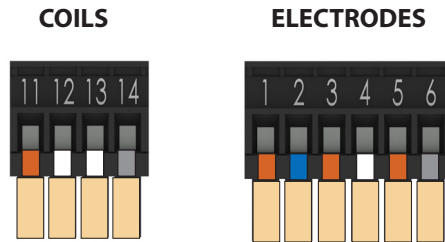
#### Mags Retro-Fit Wiring Diagram



#### FPI/FPI Plus Wiring Diagram



#### UM/FM/VM Wiring Diagram



#### Outputs Block

Terminal	Cable
<b>OUTPUTS</b>	
26	PULSE 1 (+)
25	PULSE 1 (-)
24	PULSE 2 (+)
23	PULSE 2 (-)
22	4-20 (+)
21	4-20 (-)

#### AMI Block

Terminal	Cable
<b>AMI</b>	
33	DATA
32	CLOCK
31	GROUND

#### Dual 4-20mA/Hart Block

Terminal	Cable
<b>4/20 / HART CARD</b>	
45	HART & 4-20 CH 2 (+)
44	HART & 4-20 CH 2 (-)

#### Modbus Block

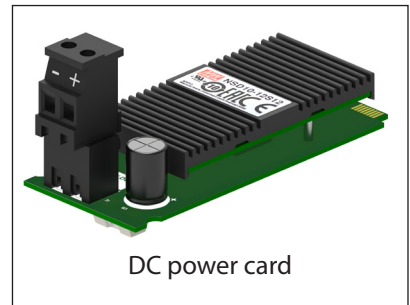
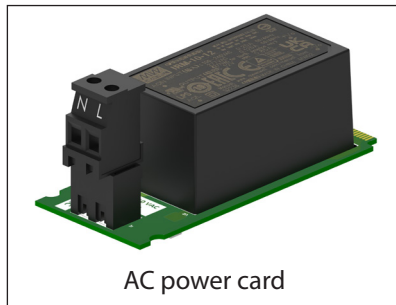
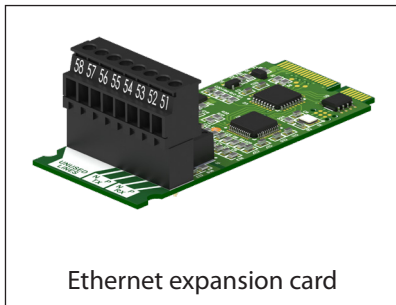
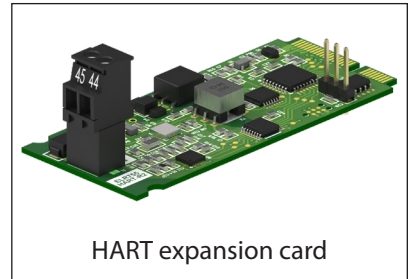
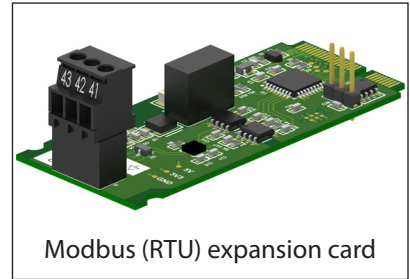
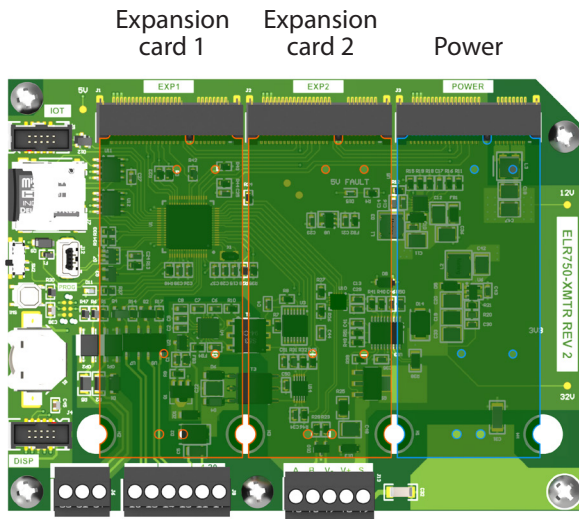
Terminal	Cable
<b>MODBUS RS485 CARD</b>	
41	GND
42	B
43	A

#### Ethernet IP Block

Terminal	Cable	Color
<b>ETHERNET CARD</b>		
51	RX+	Green
52	RX-	White Green
53	TX+	Orange
54	TX-	White Orange
55	TRD1	Brown
56	TRD1	White Brown
57	TRD1	Blue
58	TRD1	White Blue

note 1: Signal not used, termination still required

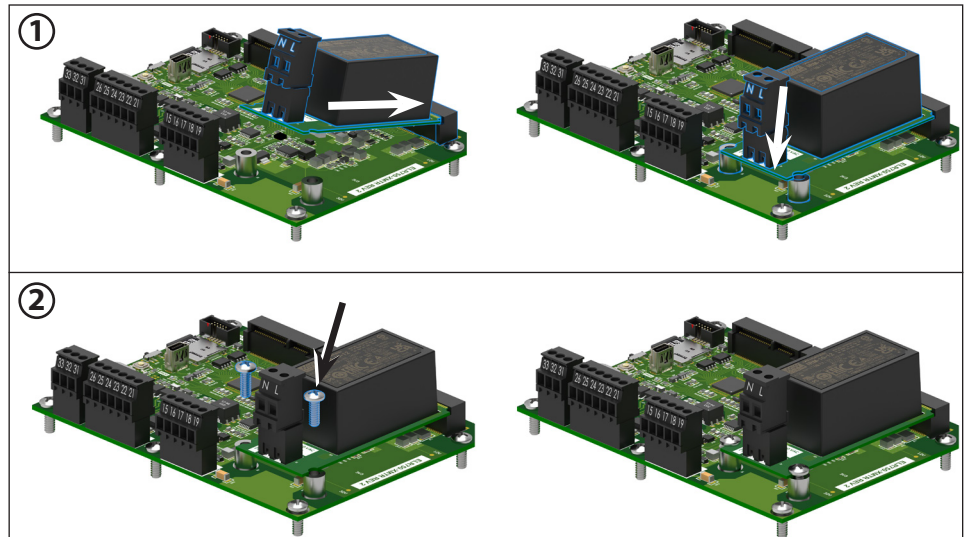
### 3.2 Installing Expansion Cards



#### Inserting the expansion card

Refer to the images that accompany each step. The AC power card is shown as an example. See section 3.5 for wiring diagrams for both AC and DC power.

- Slide the card into the connection slot. Set the card flat on the two support posts.
- Insert and tighten two screws to secure the card in place.



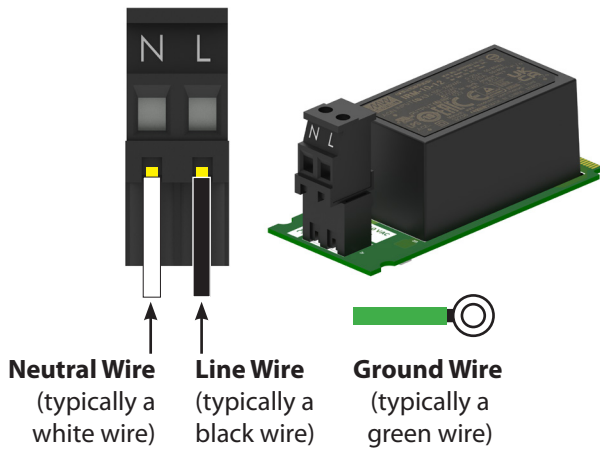
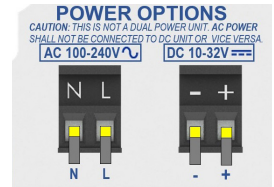
### 3.3 Transmitter Power Wiring Diagram

**WARNING!**  
Hazardous supply voltage can shock, burn, or cause death.

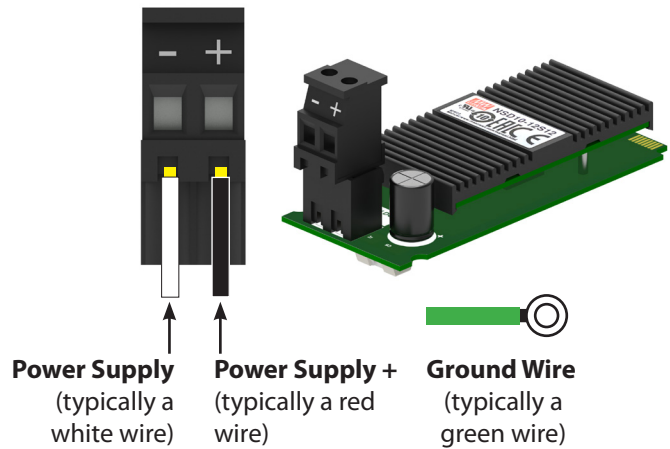
These instructions are for connecting either the AC or DC power option. The connections are shown below above the appropriate power card.

Install the power card as described in section 3.4. Connect power as shown below in Figure 15 and Figure 16.

The power supply line must be equipped with external surge protection for current overload (fuse or circuit breaker with limiting capacity not greater than 10A). It must be easily accessible for the operator and clearly identified.

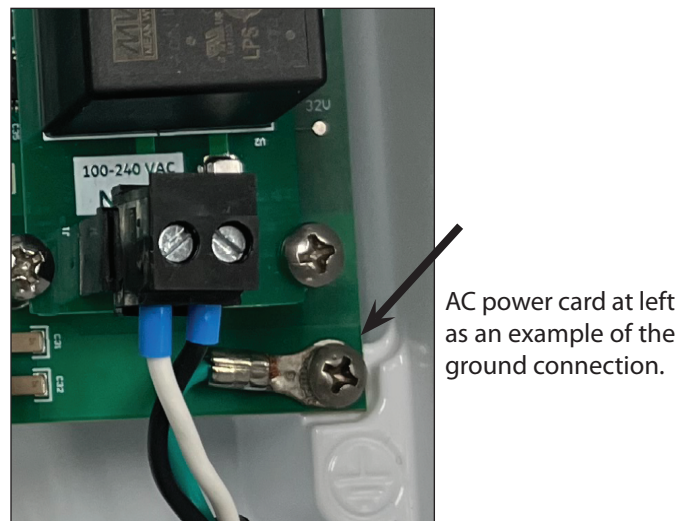
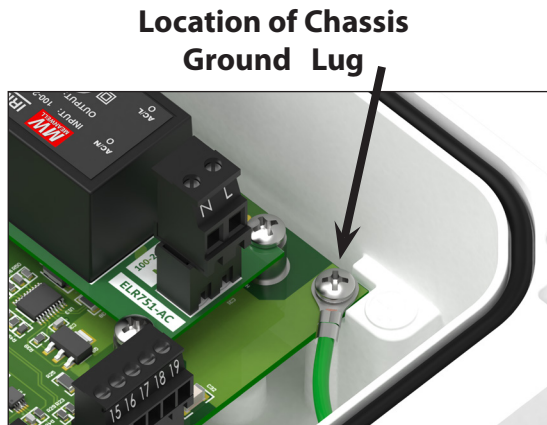


**Figure 15. AC Power Supply Terminal Block**



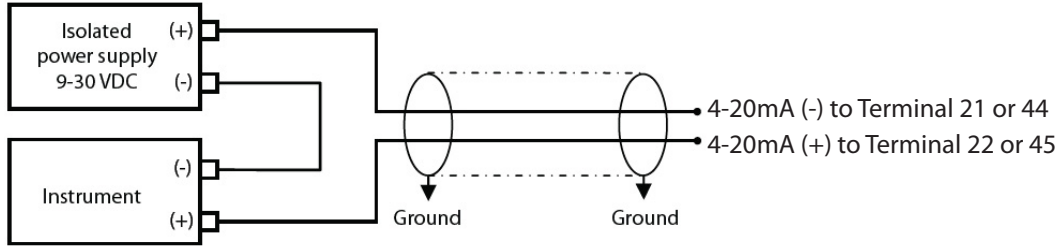
**Figure 16. Optional DC Power Supply Terminal Block**

#### Chassis Ground Connection

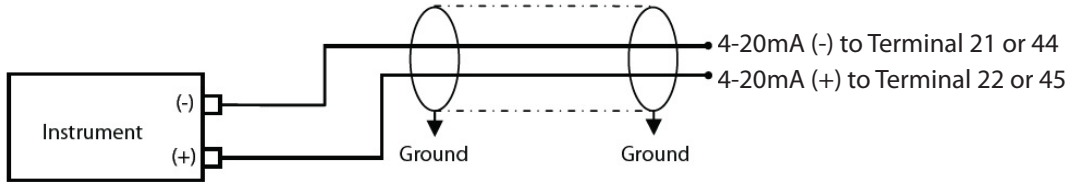


### 3.4 4-20mA Hook-Up

Output type: 4-20mA current loop, CH.1 and Ch.2 source power off (passive)



Output type: 4-20mA current loop, source power on (active)



**Figure 17. 4-20mA Hook-Up**

If the external device requires a voltage input, a precision resistor placed across the input terminals of the external device will change the current to voltage. Calculate the required resistor using Ohm’s law ( $V = I \times R$ ). For example, a 250Ω resistor will provide an input voltage of one to five volts with the transmitter range being set from 4mA to 20mA. An additional 4-20mA loop output is available.

Meter source power is 12V for loop power. Max resistance with source power is 300 ohms. Sink power supplied for loop from external device range is 12 – 30 V DC. Max resistance with external sink power is  $R_{max} = 50 * (V_{in} - 5)$

**I IMPORTANT** The 4-20mA output can be sink or source powered which is selectable in the menus. Default setting is source powered to avoid damage to the circuit. Do not select source powered if the 4-20 loop has sink power from the 4-20 instrument.

### 3.5 HART Hook-Up

The outputs of the 4-20mA channel 2 interface also support HART communication. This interface uses the same (+) and (-) terminals and requires the same physical connection.

### 3.6 Opto-Isolated Pulse Output Hook-Up

The outputs are open collector solid state relay outputs used to communicate with or activate external devices.

- Opto-isolated solid state relay open collector
- Maximum switching voltage: 80 VDC
- Maximum switching current: 8 ohms
- Isolation from other secondary circuits: 500 V
- Pulse width range 5ms – 1 second

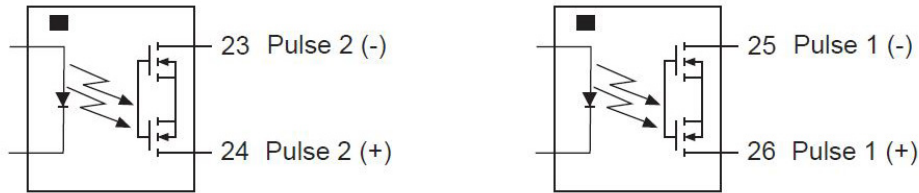


Figure 18. Pulse Hook-Up

### 3.7 Optional Smart Output Hook Up

The transmitter comes pre-wired with an interconnection that should readily connect to most AMI transceivers. Where interconnective devices are not mechanically compatible or where non-standard wiring is encountered, the installer can opt to remove the connector from the end of the transmitter's interface cable and make direct connection via the wiring table shown at right.

- Signals and associated wire colors in the McCrometer SmartOutput™ interface cable are identified together in the top row of the table at right.
- Corresponding wire colors for transceivers from each compatible AMI vendor are identified in the columns under the top row.

McCrometer AMR Interface Pinout

	33 Data	32 Power/Clock	31 Ground
<b>Badger</b>	Red	Green	Black
<b>Elster</b>	Green	Red	Black
<b>Itron</b>	Black	Red	Green
<b>Neptune</b>	Black	Red	Green
<b>Sensus</b>	Red	Green	Black
<b>SmartTrax</b>	Blue	White	Black



### 3.8 Connecting the optional SmartTrax Remote Transmitting Unit

For more detail on the SmartTrax transmitter, including specifications, installation requirements, location, and remote data access, see the SmartTrax Installation, Operation, and Maintenance manual, 30125-82.

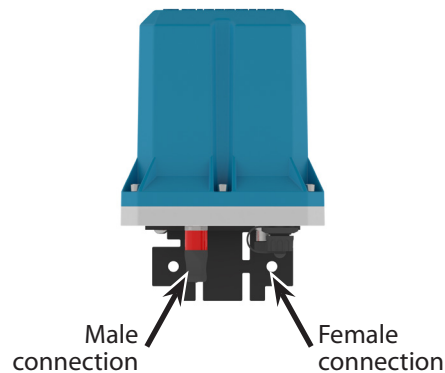


Figure 19. Connections, front view

## 4.0 TRANSMITTER OPERATION

### 4.1 Starting up the Transmitter







Before starting up the transmitter please verify the following:

- Power supply voltage must correspond to that specified on the data plate (located on the side of the transmitter)
- Electric connections must be wired as described in this manual
- Ground connections must be properly installed

**NOTE:** To view alarms, press the RIGHT arrow key from the main display screen.

#### 4.1.1 Menu Navigation

To navigate through the menus on the transmitter, the keys on the keypad use the following conventions:

Key	Function
 <b>UP Key</b>	Moves the cursor up to the previous subject on the menu Increases the numeric figure of the parameter highlighted by the cursor
 <b>DOWN Key</b>	Moves the cursor down to the next subject on the menu Decreases the numeric figure of the parameter highlighted by the cursor
 <b>LEFT Key</b>	Moves the cursor to the left on the input field Moves the cursor to the previous subject on the menu
 <b>RIGHT Key</b>	Moves the cursor to the right on the input field Moves the cursor to the following subject of the menu
 <b>ENTER Key</b>	Opens the Quick Start menu for the instrument configuration Enters the selected function Confirms the selected function
 <b>ESC Key</b>	Leaves the current menu Cancels the selected function under progress

## 4.2 Default Screens While Transmitter Is Operating

### Single Direction Only

```

965.2 GPM
      71 GAL
      X1000
    
```

### Bidirectional (NEG) (if enabled)

```

963.2 GPM
POS      62754
NEG      0  GAL
    
```

### Bidirectional (NET) (if enabled)

```

964.9 GPM
POS      71
NET      63  GAL
      X1000
    
```

### Batch with POS Total

```

965.2 GPM
POS      71
BATCH ↓  63  GAL
HOLD     RST
    
```

### Batch with Net Total

```

965.2 GPM
NET      62642
BATCH   337  GAL
HOLD ↓  RST
    
```

### Alarms

```

ALARMS
COIL CURRENT LOW
LOW VOLTAGE
    
```

### Diagnostics (page 1)

```

DIAGNOSTICS
EP      188      190
ADC     5650190      Δ 1
      -6033157      Δ 2
      58505         MA
PG1
    
```

### Diagnostics (page 2)

```

DIAGNOSTICS
COIL           118.6  mA
              13.2   U
              111.8  Ω
TEMP          36.4   C
HUM           39.6   RH
PG2
    
```

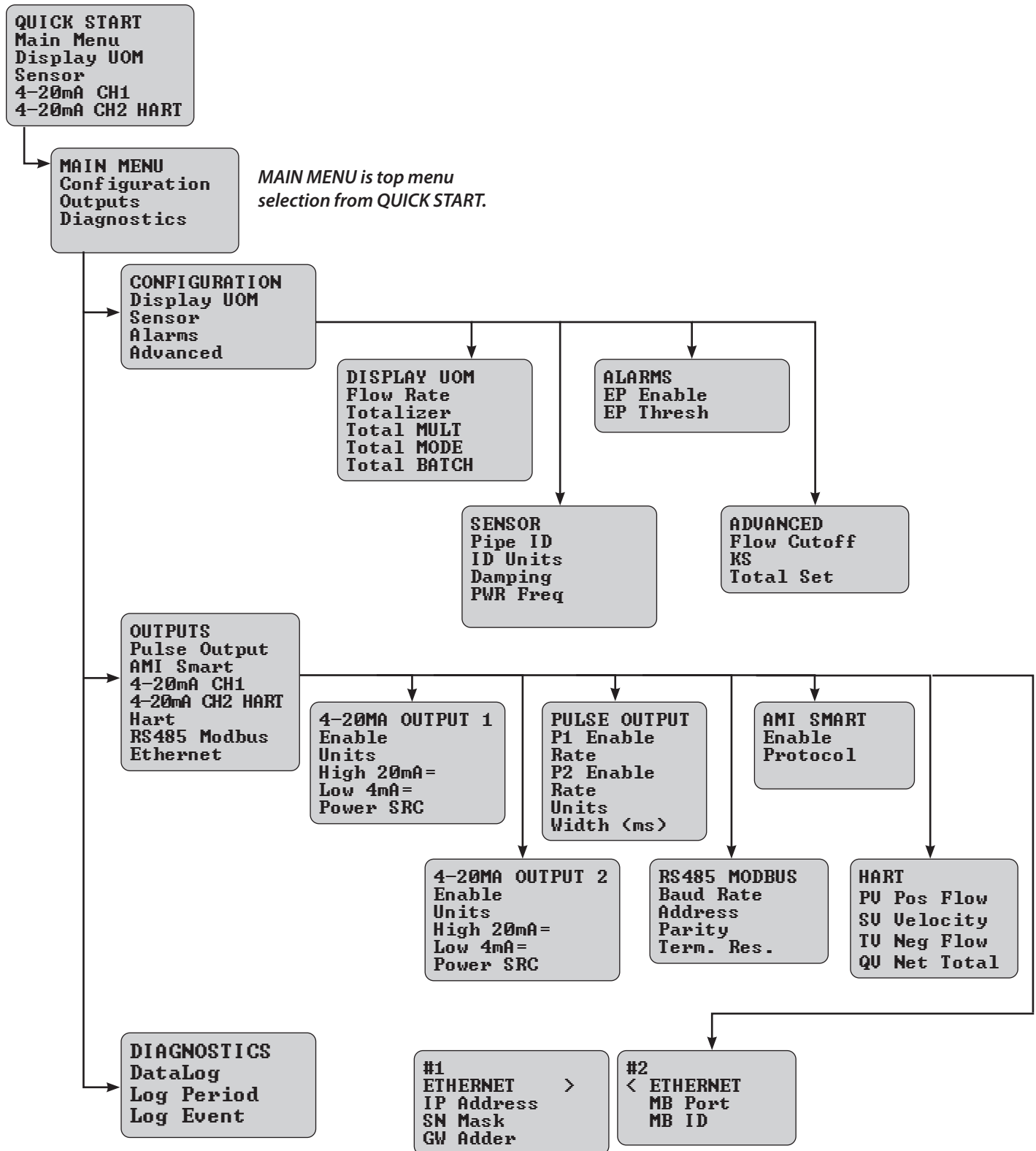
### System Info

```

SYSTEM INFO
SENS SN:FP23-0399
XMTR SN:E23-07859
TAG:FP230399
FW:0.14.0
Card 1 <if installed>
Card 2 <if installed>
    
```

### 4.3 Menu Structure

The following is the menu structure for the ProComm Max transmitter. NOTE: Some menus change as options are enabled.



## 4.4 Menu Configuration

The following is the menu Configuration for the ProComm Max transmitter.

Menu Number	Function Name	Function Description	[ Minimum, Maximum] Values	Details
<b>1.0</b>	Configuration	Meter and Unit Configuration Submenu		Menu only
<b>1.1</b>	Display UOM	Unit of Measures Submenu		Menu only
1.1.1	Flow Rate	Selects the flow rate Unit (GPM, MGD...)	See Rate Unit Table	Table 5
1.1.2	Totalizer	Selects the Totalizer Unit (GAL, CUF...)	See Total Unit Table	Table 6
1.1.3	Total MULT	Selects the Totalizer Multiplier (x1, x10...)	See Total Multiplier Table	Table 7
1.1.4	Total MODE	Select Which Totals to be Displayed	[Fwd, Rev, Net]	
1.1.5	Total BATCH	Enables Batch totals (Holding down arrow resets total via display)	[Off, Pos, Neg]	
<b>1.2</b>	SENSOR	Displays Technical Details about the Meter		Menu only
1.2.1	Pipe ID	Displays and Sets the Meter Internal Diameter Used for Flow Rate	[1, 150]	
1.2.2	ID Units	Displays and Sets the Unit of Measure for the Internal Diameter	[in, cm]	Menu only
1.2.3	Damping	Sets the Amount of Damping in Flow Reading in Seconds	[2s, 60s]	
1.2.4	PWR Freq	Sets Filtering for Main Power A/C Frequency to 50/60 Hz	[50, 60] Hz	
1.2.5	Flow Vel	Flow velocity Units	[FT/S, M/S]	
<b>1.3</b>	ALARMS	Set Alarms for Empty Pipe (EP) and Ep Threshold		Menu only
1.3.1	EP Enable	Enable/Disable Empty Pipe Alarm	[On, Off]	
1.3.2	EP Thresh	Set EP Threshold alarm value [default = 1500]	[0, 4000]	
<b>1.4</b>	ADVANCED	Set Advanced features		Menu only
1.4.1	Flow Cutoff	Sets the Low Flow Cutoff Value in FT/S	[0.05, 5]	
1.4.2	KS	Linear Flow multiplier for in field changes to flow reading	[0, 10]	
1.4.3	Total Set	Sets the Totalizer Value to a User Defined Value	[0, 9999999999.9]	
1.4.4	Cal Coef	Sets the Calibration Coefficients for the Gains and Offsets		Menu only
	K		Values only from Factory	
	A		Values only from Factory	
	B		Values only from Factory	
	Z		Values only from Factory	

#### 4.4 Menu Configuration (continued)

The following is the menu Configuration for the ProComm Max transmitter.

Menu Number	Function Name	Function Description	[ Minimum, Maximum] Values	Details
<b>2.0</b>	OUTPUTS	Outputs Submenu		Menu only
<b>2.1</b>	Pulse Output	Pulse/ Digital Output Submenu		Menu only
2.1.1	P1 Enable	Enables Pulse 1 Output (Forward Flow)	[On, Off]	
2.1.2	Rate	Sets Pulse 1 Rate per pulse	[.01, 9999] via menu	
2.1.3	P2 Enable	Enables Pulse 2 Output (Reverse Flow)	[On, Off]	
2.1.4	Rate	Sets Pulse 2 Rate per pulse	[.01, 9999] via menu	
2.1.5	Units	Sets Pulse Rate Units of Measure	See Total Unit Table	Table 6
2.1.6	Width <ms>	Sets Pulse width in milliseconds (Period = 2 times Pulse width)	[3, 1000]	
<b>2.2</b>	AMI Smart	AMI Smart Output Submenu		Menu only
2.2.1	Enable	Enable AMI Output (OFF, Positive Tolatizer...)	[Off, On, STX, Net]	
2.2.2	Protocol	Sets Protocol Configuration (SEN, NEP, IT6...)	(SEN, NEP, IT6, IT9, MUL)	
<b>2.3</b>	4-20mA CH1	Native Channel 1 Analog Submenu		Menu only
2.3.1	Enable	Enable 4-20mA Output	[On, Off]	
2.3.2	Units	Sets 4-20mA Units of Measure (GPM, MGD...)	See Rate Unit Table	Table 5
2.3.3	High 20mA =	Sets Full Scale Value (20mA)	[-999999.99, 999999.99]	
2.3.4	Low 4mA =	Sets Low Value (4mA)	[-999999.99, 999999.99]	
2.3.5	Power SRC	Enables 12V Power source from device to power loop	[On, Off]	
<b>2.4</b>	4-20mA CH2 HART	Optional Channel 2 Analog Submenu	If Hart Card is Connected	Menu only
2.4.1	Enable	Enable 4-20mA Output	[On, Off]	
2.4.2	Units	Sets 4-20mA Units of Measure (GPM, MGD...)	See Rate Unit Table	Table 5
2.4.3	High 20mA =	Sets Full Scale Value (20mA)	[-999999.99, 999999.99]	
2.4.4	Low 4mA =	Sets Low Value (4mA)	[-999999.99, 999999.99]	
2.4.5	Power SRC	Enables 12V Power source from device to power loop	[On, Off]	

#### 4.4 Menu Configuration (continued)

The following is the menu Configuration for the ProComm Max transmitter.

Menu Number	Function Name	Function Description	[ Minimum, Maximum] Values	Details
<b>2.5</b>	HART	Optional Hart Submenu	If Hart Card is connected	Menu only
2.5.1	PV Pos Flow	Hart Register Output Selection (POS Flow, NEG Flow....)	See Hart Dynamic Variable Table	Table 8
2.5.2	SV Velocity	Hart Register Output Selection (POS Flow, NEG Flow....)	See Hart Dynamic Variable Table	Table 8
2.5.3	TV Neg Flow	Hart Register Output Selection (POS Flow, NEG Flow....)	See Hart Dynamic Variable Table	Table 8
2.5.4	QV Net Total	Hart Register Output Selection (POS Flow, NEG Flow....)	See Hart Dynamic Variable Table	Table 8
<b>2.6</b>	RS485 Modbus	Optional RS485 RTU Submenu	If RTU Card is Connected	Menu only
2.6.1	Baud Rate	Sets Baud Rate	See Modbus Baud Rate Table	Table 1
2.6.2	Address	Sets RS485 Modbus Address	[1,247]	
2.6.3	Parity	Sets RS485 Modbus Parity	[Even, Odd, None]	
2.6.4	Term_ Res_	Enable Slew Rate Resistor (ON/OFF)	[On, Off]	
<b>2.7</b>	Ethernet	Optional Ethernet Submenu	If Ethernet Card is Connected	Menu only
2.7.1	IP Address	Sets Ethernet IP Address	Default [192.168.2.11]	Should be done via keypad (Table 14)
2.7.2	SN Mask	Sets SUBNET IP Address	Default [255.255.0.0]	Should be done via keypad (Table 14)
2.7.3	GW Addr	Sets GATEWAY IP Address	Default [255.255.250.0]	Should be done via keypad (Table 14)
2.7.4	MB Port	Sets Modbus Port	[0, 255]	
2.7.5	MB ID	Sets Modbus Slave ID Number	[0, 255]	
<b>3.0</b>	DIAGNOSTICS	Datalog and Diagnostic Submenu		Menu only
3.1.1	DataLog	Enable DataLogging via SD Card	[On, Off]	
3.1.2	Log Period	Sets Logging Period in Hours	[1, 48]	
3.1.3	Log Event	Manually log current values to datalog	N/A	
3.1.4	Flow Sim	Enable Flow Simulation	[On, Off]	
3.1.5	Sim Rate	Sets Simulation Rate Value in gallons	[-99999, 99999]	
3.1.6	Reboot	Use to Reboot Transmitter and Converter Electronics		

**5.0 ALARM MESSAGES**

ALARM ON SCREEN	DESCRIPTION	TROUBLESHOOTING STEPS
No 4-20mA Sig 1	4-20mA circuit is enabled but not able to run current.	Check circuit wiring and voltage on circuit. Disable the output if not in use to remove alarm.
Coil Current Low	The current running on the coils to produce the magnetic field is not able to meet the desired value.	Check for coil current and resistance on diagnostic screen page 2. Coil current should be between 100-200. Coil resistance should be less than 210. If there are no values shown there, then check coil wiring on terminal block pins 11-14 at converter PCB for a loose or missing wire. If wire connection is good, then the problem is located in the sensor body, contact factory.
High Humidity	Humidity sensor reading above set threshold	Check converter housing on sensor for any water ingress. Retighten housing lid. Humidity reading may take some time to drop down below threshold of 80%RH. Converter temp and RH readings can be found on diagnostic screen page 2. If alarm persists, contact factory.
Coincell Bat Low	Coincell battery voltage low	Check for a coin cell battery on the transmitter. If present, try removing and cleaning off both sides of the coin cell and re install. Power cycle transmitter to confirm coin cell voltage is checked. If still low, contact factory for replacement.
Low Voltage	There is a power issue between the converter and transmitter.	Check sensor cable connector terminal block on transmitter (pins 15-19) for a loose or missing connection. Check wiring diagram for correct pinout. Check the length of the cable to the sensor for any cuts or disconnects. Check input power to the transmitter. Power cycle the transmitter. If problem persists, contact factory.
Conv Msg Timeout	There is a communication issue between the converter and transmitter.	Check sensor cable connector terminal block on transmitter (pins 15-19) for a loose or missing connection. Check wiring diagram for correct pinout. Power cycle the transmitter. If problem persists, contact factory.

Invalid Flo Read	The flow reading is above the maximum allowed value (factory set 40 ft/s)	Check grounding of sensor and any possible sources of electrical noise near the transmitter, sensor or to the water column. If alarm persists, record ADC readings from the diagnostic screen page 1 and contact factory.
Sig Out Of Range	Raw signal readings are exceeding the maximum realistic values due to flow likely caused by noise.	
ADC Clipping	Raw signal readings are exceeding the allowable range of the converter, likely caused by a significant voltage offset in the water column.	
SD Init Failure	The micro SD card failed communication for datalogging.	Check the SD card. Turn off power and remove and re install SD card, turn power back on. If alarm persists, contact factory.
High Flow	This is a user set high flow alarm. This will alarm whenever the flow is higher than the value set in the menu.	Set the max flow parameter in the alarms menu. The value is used in the displayed flow rate units.

## 5.1 FIRMWARE UPDATES

Firmware upgrades, and upgrade instructions are available at <https://www.mccrometer.com/software/firmware-updates>

## 6.0 MODBUS PROTOCOL

ProComm Max devices equipped with either the optional RS485 Expansion Card or the optional Ethernet Expansion Card are capable of communication as a Slave device on a MODBUS Network with typical Master/Slave architecture. The RS485 Card supports MODBUS RTU. The Ethernet Card supports MODBUS TCP.


**WARNING**

THE PROCOMM MAX DEVICE MUST FIRST BE DISCONNECTED FROM ITS POWER SOURCE BEFORE ATTEMPTING INSTALLATION OR WIRING OF EXPANSION CARDS. IGNORING THIS WARNING MAY RESULT IN IRREPARABLE DAMAGE TO YOUR PROCOMM MAX DEVICE

### 6.1 Hardware Installation & Wiring

Refer to Section 3.3 for installation and wiring details.

### 6.2 Configuration

Refer to Section 4.2 for menu navigation details.

Various parameters must be configured to communicate on a MODBUS network. Refer to Table I for details relating MODBUS RTU. Refer to Table II for details relating to MODBUS TCP.

**Table 1. MODBUS RTU Configuration**

Field	Default	Options
Slave ID	1	1-247
Baud	9600	1200, 2400, 4800, 9600, 19200, 38400, 57600, 115200
Parity	None	Even, Odd, None
Termination	No	Yes, No

*note 1: Termination must be enabled on the last device on any MODBUS RS485 communication line*

**Table 2. MODBUS TCP Configuration**

Field	Default	Options
IP Address	192.168.1.1	Configure in accordance with local network requirements
Subnet Mask	255.255.0.0	
Gateway Address	255.255.255.0	
MB Port	1	1-247
MB ID	1	1-247

### 6.3 Communication

The following register map is accessible via MODBUS RTU and MODBUS TCP protocols:

**Table 3. MODBUS Input Registers**

Address Offset	Registers	Bits	Type	Data	Description
0000-0001	2	32	Float	Flow Rate	Flow rate (units: 0002)
0002	1	16	UINT	Flow Rate Units	see Table V
0003-0004	2	32	UINT	Totalizer (+)	Pos Total (units: 0007)
0005-0006	2	32	UINT	Totalizer (-)	Neg Total (units: 0007)
0007	1	16	UINT	Totalizer Units	see Table VI
0008	1	16	UINT	Totalizer Multiplier	see Table VII
0009-0010	2	32	UINT	Batch Total (+)	Partial Total: P+ value
0011-0012	2	32	UINT	Batch Total (-)	Partial Total: P- value
0013-0014	2	32	Float	Flow Rate (linear)	Velocity (ft/sec)
0015-0016	2	32	Float	Full Scale	Full scale flow rate

*Note: Starting address is 30001*

*Note: To read data, use Function Code 04*

*Note: Read-only*

Users upgrading to ProComm Max from the legacy ProComm platform can reference Table IV below to quickly finding updated address offsets.

**Table 4: ProComm vs. ProComm Max**

Data	Procomm Address Offset	ProComm Max Address Offset
Full Scale	0000-0001	0015-0016
Flow Rate	0004-0005	0000-0001
Flow Rate (linear)	0006-0007	0013-0014
Totalizer (+)	0008-0009	0003-0004
Batch Total (+)	0011-0012	0009-0010
Totalizer (-)	0014-0015	0005-0006
Batch Total (-)	0017-0018	0011-0012

Following are the maps for process data.

**Table 5. Flow Rate Units**

Address 0002	
value	unit
0	Gallons per Minute
1	Mega Gal per day
2	Cubic Feet per Second
3	Megaliters per day
4	Liters per second
5	Cubic Meters per Hour
6	Liters per Minute
7	Gallons per hour
8	Imperial Gal per Minute
9	Miners Inch (9G)
10	Miners Inch (11.22G)
11	Acre Feet per day
12	Kiloliters per hour
13	Liters per hour
14	Cubic Meters per minute
15	Cubic feet per minute
16	Barrels per minute (55G)
17	Barrels per Hour (55G)
18	Barrels per Day (55G)
19	Barrels per minute (42G)
20	Barrels per Hour (42G)
21	Barrels per Day (42G)

**Table 6. Totalizer Units**


Address 0007	
value	unit
0	Gallons
1	Cubic Feet
2	Acre Feet
3	Cubic Meters
4	Liters
5	Megaliter
6	Metric Ton (KL)
7	Barrel (31G)
8	Barrel (42G)
9	Barrel (46G)
10	Barrel (55G)
11	Imperial Gallon
12	Acre Inch
13	Ton (Short)
14	Miners Inch Minute (11.22G)
15	Miners Inch Hour (11.22G)
16	Miners Inch Day (11.22G)
17	Miners Inch Minute (9G)
18	Miners Inch Hour (9G)
19	Miners Inch Day (9G)
20	Kilo Gallons
21	Mega Gallons
22	Cubic Inch

**Table 7. Totalizer Multiplier**

Address 0008	
value	unit
0	X1
1	X10
2	X100
3	X1000
4	XMEGA
5	0.1
6	0.01
7	0.001
8	0.0001

## 7.0 HART PROTOCOL

ProComm Max devices equipped with the optional HART Expansion Card are capable of point-to-point communication as a Slave device with a HART-capable Master device, or with a HART-enabled 4-20 Master device.



**WARNING**  
 THE PROCOMM MAX DEVICE MUST FIRST BE DISCONNECTED FROM ITS POWER SOURCE BEFORE ATTEMPTING INSTALLATION OR WIRING OF EXPANSION CARDS. IGNORING THIS WARNING MAY RESULT IN IRREPARABLE DAMAGE TO YOUR PROCOMM MAX DEVICE

### 7.1 Hardware Installation and Wiring

Refer to Section 3.3 for installation and wiring details.

### 7.2 Configuration

Refer to Section 4.2 for menu navigation details.

After card installation, the following four HART parameters, called Dynamic Variables, can be configured in the ProComm MAX menu to hold various Device Variables.

**Table 8: Dynamic Variables**

Code	Dynamic Variable	Default Device Variable
PV	Primary	0 (Forward flow Rate)
SV	Secondary	1 (Flow Velocity)
TV	Tertiary	2 (Reverse Flow Rate)
QV	Quaternary	3 (Net Totalizer)

Refer to Table II for a list of Device Variables that can be stored in the above Dynamic Variables.

**Table 9: Device Variables**

Device Variable	Type	Data	Description
0	FLOAT	Forward Flow Rate	Flow rate incrementing the positive totalizer
1	FLOAT	Flow Velocity	Linear Flow rate in ft/sec
2	FLOAT	Reverse Flow Rate	Flow rate incrementing the negative totalizer
3	FLOAT	Net Totalizer	Difference of Positive and Negative Totals
4	FLOAT	Totalizer (+)	Positive Flow Total Value
5	FLOAT	Totalizer (-)	Negative Flow Total Value
6	FLOAT	Batch Total (+)	Positive Resettable Batch Total Value
7	FLOAT	Batch Total (-)	Negative Resettable Batch Total Value

## 7.3 Communication

### 7.3.1 Settings

Various requirements must be observed for an external device to use HART Protocol to communicate with the ProComm MAX device. Refer to Table III for details.

**Table 10: Communication Settings**

Polling address	0
Preamble	5 (0xFF, 0xFF, 0xFF, 0xFF, 0xFF)
Universal commands	0, 1, 2, 3
HART protocol revision	7

### 7.3.2 Commands

The optional HART Expansion Card supports various Universal Commands and will respond to any HART revision 7 Master device, handheld or otherwise. These commands adhere to HART protocol revision 7. Refer to Table III for detailed information.

**Table 11: Commands**

Cmd	Description	Start Delimiter	Address Field Format
0	Read unique identifier	0x02	Short frame
1	Read primary variable	0x82	Long frame
2	Read current and % of range	0x82	Long frame
3	Read current and dynamic variables	0x82	Long frame

**Note:** HART commands not described in Table IV are not supported

**Note:** Unit Codes described in Tables V and VI

**Note:** Device Identification Number contains a partial serial number. E.g., FP24-0123 becomes 240123.

**Table 12: Flow Rate Units**

Code	Unit
15	Cubic feet per minute
16	Gallons per Minute
17	Liters per Minute
18	Imperial Gal per Minute
19	Cubic Meters per Hour
23	Mega Gal per day
24	Liters per second
25	Megaliters per day
26	Cubic Feet per Second
131	Cubic Meters per minute
133	Barrels per minute (42G)
134	Barrels per Hour (42G)
135	Barrels per Day (42G)
136	Gallons per hour
138	Liters per hour
240	Acre Feet per day
241	Kiloliters per hour
246	Barrels per minute (55G)
247	Barrels per Hour (55G)
248	Barrels per Day (55G)
249	Miners Inch (9G)
249	Miners Inch (11.22G)

**Table 13: Totalizer Units**

Code	Unit
40	Gallons
41	Liters
42	Imperial Gallon
43	Cubic Meters
46	Barrel (42G)
64	Ton (Short)
112	Cubic Feet
113	Cubic Inch
124	Barrel (31G)
242	Acre Feet
243	Megaliter
244	Barrel (55G)
245	Acre Inch
249	Metric Ton (KL)
249	Barrel (46G)
249	Miners Inch Minute (11.22G)
249	Miners Inch Hour (11.22G)
249	Miners Inch Day (11.22G)
249	Miners Inch Minute (9G)
249	Miners Inch Hour (9G)
249	Miners Inch Day (9G)
249	Kilo Gallons
249	Mega Gallons

**Note:** Unit Codes 240-249 are Unit Codes not explicitly described by HART protocol

**Note:** Unit Code 249 is for all McCrometer units not described in codes 240-248

## 8.0 ETHERNET/IP PROTOCOL

ProComm Max devices equipped with the optional Ethernet Expansion Card can communicate with devices that use EtherNet/IPTM (ENIP), a proprietary protocol defined by Open DeviceNet Vendors Association (ODVA).



**WARNING**  
 THE PROCOMM MAX DEVICE MUST FIRST BE DISCONNECTED FROM ITS POWER SOURCE BEFORE ATTEMPTING INSTALLATION OR WIRING OF EXPANSION CARDS. IGNORING THIS WARNING MAY RESULT IN IRREPARABLE DAMAGE TO YOUR PROCOMM MAX DEVICE

### 8.1 Hardware Installation and Wiring

Refer to Section 3.3 for installation and wiring details.

### 8.2 Configuration

Refer to Section 4.2 for menu navigation details.

After card installation, the following settings must be configured in the ProComm MAX menu to allow EtherNet/IPTM communication. These settings are network dependent and should be configured for compatibility with the local network.

**Table 14: Network Configuration**

Field	Default	Options
IP Address	192.168.1.1	Configure in Accordance with local network requirements
Subnet Mask	255.255.0.0	
Gateway Address	255.255.255.0	

\*MB Port and MB ID found on Page 2 are only used for Modbus TCP.

### 8.3 Communication

#### 8.3.1 EtherNet/IP™

ENIP is ODVA's Ethernet-based implementation of Common Industrial Protocol™ (CIP). ENIP communicates over standard Ethernet networks built on standard hardware.

Note: Various networking hardware components exist which were designed for use with ENIP. Such hardware typically offers some ENIP-specific features but is not required.

#### 8.3.2 ProComm Max

ProComm Max implements a Generic Device CIP device type and communicates as an explicit or I/O message Server with compatible ENIP devices including explicit message Clients and I/O Scanners. Most users should refer to the PLC instructions found at the website below. Using the EDS file to connect to the ProComm Max and AOI file to configure the Dataset (All parameters in 32-byte package).

[www.mccrometer.com/software/ethernet-ip](http://www.mccrometer.com/software/ethernet-ip)

To access specific device data, use service Get\_Attribute\_Single to explicitly query instance attribute #3 of the desired Assembly Instance. Refer to communication details, section 8.3.3.

### 8.3.3 Communication Details

The following details can be used to manually set up an explicit connection to ProComm Max.

**Table 15: Communication Details**

Device Type	0x2B, Generic Device
Explicit Message Type	Connected
Protocol	TCP
Object Class	4, Assembly
Service	14 (0x0E), Get_Attribute_Single
Instance	Refer to Table IV
Attribute	3

### 8.3.4 Device Parameters

**Table 16: Device Parameters available**

#	Name	Data Type	Style	Description
1	Flow	REAL	Float	Flow rate
2	Flow_FTS	REAL	Float	Velocity (ft/s)
3	POS_TOTALIZE	DINT	Decimal	Positive totalizer (in chosen units)
4	NEG_TOTALIZE	DINT	Decimal	Negative totalizer (in chosen units)
5	POS_BATCH	DINT	Decimal	Positive batch (in chosen units)
6	NEG_BATCH	DINT	Decimal	Negative batch (in chosen units)
7	Flow_Units	INT	Decimal	Flow Rate Units
8	Total_Units	INT	Decimal	Totalizer units
9	Total_Mult	INT	Decimal	Total Multiplier (x1, x10, x100,x1000,...)

*Note: all data is sent in Little Endian byte order*

### 8.3.5 Assembly Instances

Various permutations of the parameters in Table IV comprise the Assembly Instances (below).

**Table 17: Assembly Instances**

Instance #	Assembly	Parameters								
		1	2	3	4	5	6	7	8	9
0x01	Flow rate	1			7			2		
0x02	Positive total	3			8			9		
0x03	Negative total	4			8			9		
0x04	Positive batch	5			8			9		
0x05	Negative batch	6			8			9		
0x06	All	1	2	3	4	5	6	7	8	9

## 9.0 SPECIFICATIONS

### Physical Specifications

<b>Electronic Housing</b>	Diecast aluminum, powder coated enclosure w/ tamper resistant seal
<b>Transmitter Dimensions</b>	Remote Mount: Height: 7.3" (18.5 cm) Width: 8.5" (21.6 cm) Depth: 4.3" (10.9 cm) Meter Mount: Height: 6.9" (17.5 cm) Width: 7.2" (18.25 cm) Depth: 6.2" (15.7 cm)
<b>Power</b>	AC Power: 100-240 VAC / 47-66 Hz (10 W) DC Power: 10-35 VDC (10 W) Note: AC or DC must be specified at time of ordering.
<b>Connection Options</b>	Conduit option: 1/2" NPT threaded connections
<b>Galvanic Isolation</b>	All outputs are galvanically isolated from power supply up to 500 V
<b>Conductivity</b>	Minimum conductivity of 5µS/cm

### Performance and Operational Specifications

<b>Location</b>	Indoor or outdoor use
<b>Operating and Storage Temperature</b>	-4° to 140° F (-20° to 60° C)
<b>IP Rating</b>	IP67 Die cast aluminum transmitter
<b>Standard Outputs</b>	Bi-directional capable Single 4-20mA (standard). Galvanically isolated and fully programmable for zero and full scale. A second 4-20mA is available. <ul style="list-style-type: none"> <li>• Volumetric Pulse (Pulse 1 positive, Pulse 2 negative)</li> <li>• Maximum switching voltage: 35 VDC</li> <li>• Maximum switching current: 100mA</li> <li>• Insulation from other secondary circuits: 500V</li> <li>• Datalogger (12-hour logging period as default)</li> </ul>
<b>Optional Outputs</b>	<ul style="list-style-type: none"> <li>• Modbus</li> <li>• HART</li> <li>• Smart Output™ (Sensus, Itron 6, Itron 9)</li> <li>• Ethernet IP</li> </ul>

### Display and Measurement

<b>Keyboard and Display</b>	Can be used to access and change set-up parameters using six membrane keys and an LCD display					
<b>Units</b>	GAL	Gallons	B42	Barrel (42G)	MH1	Miners Inch Hour (11.22G)
	CUF	Cubic Feet	B46	Barrel (46G)	MD1	Miners Inch Day (11.22G)
	AFT	Acre Feet	B55	Barrel (55G)	MH9	Miners Inch Hour (9G)
	CUM	Cubic Meters	IMG	Imperial Gallon	MD9	Miners Inch Day (9G)
	LIT	Liters	AIN	Acre Inch	KGL	Kilo Gallons
	MML	Megaliter	TON	Ton (Short)	MGL	Mega Gallons
	MTT	Metric Ton (KL)	MM1	Miners Inch Minute (11.22G)	IN3	Cubic Inch
	B31	Barrel (31G)	MM9	Miners Inch Minute (9G)		

**Other Specifications**

**Standard Model**

- ISO 9001:2015 certified quality management system
- Certified by MET to UL 61010-1

**HL Model**

- ISO 9001:2015 certified quality management system
- Certified by MET to UL 61010-1 and MET C22.2 No. 61010-1-04
  - Class I, Division 2, Groups A B C D, T4
  - Class I, Zone 2, IIC T4



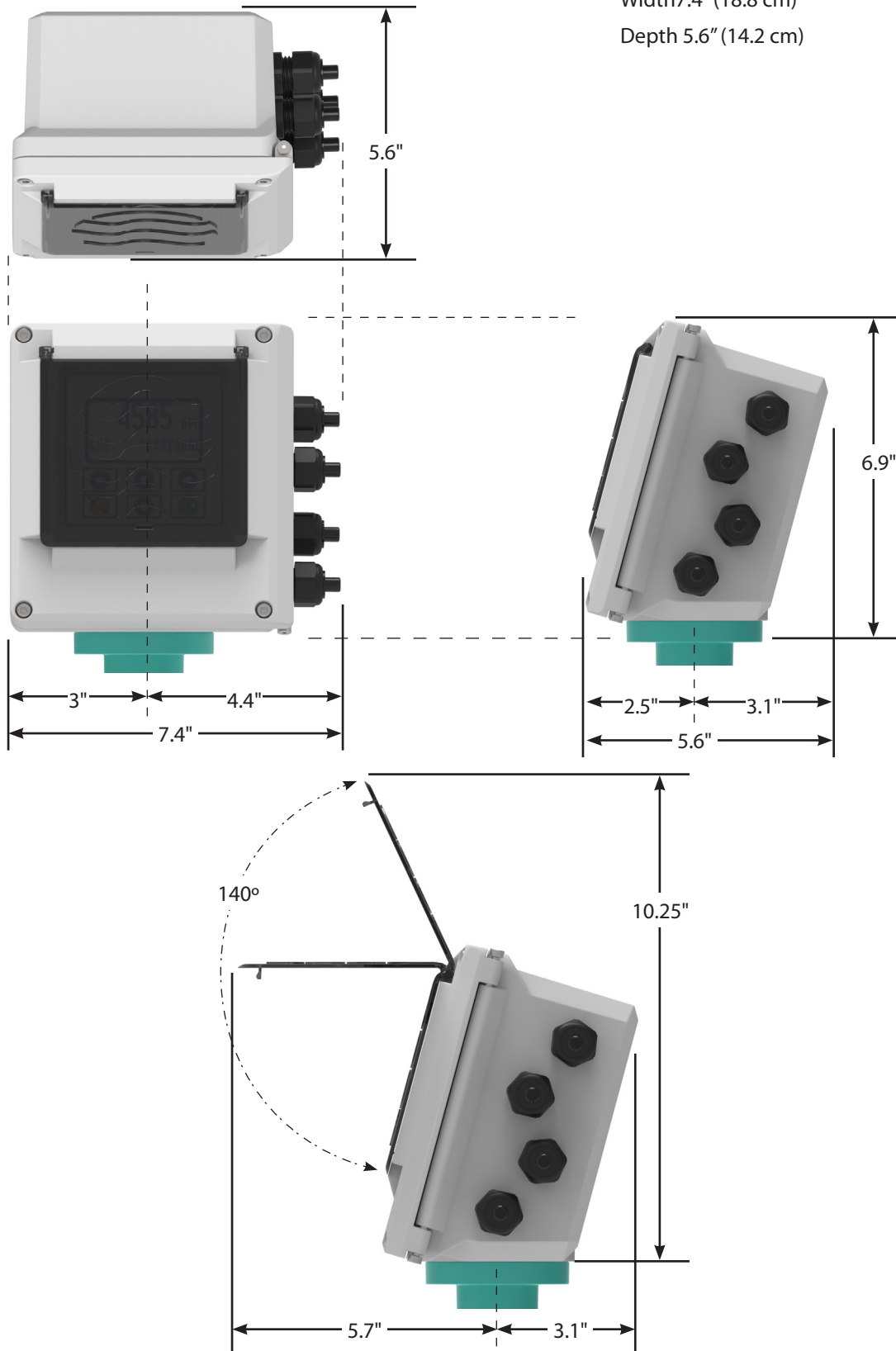
**IMPORTANT**

Refer to certification requirements. Do not substitute components.

**10.0 DIMENSIONS**

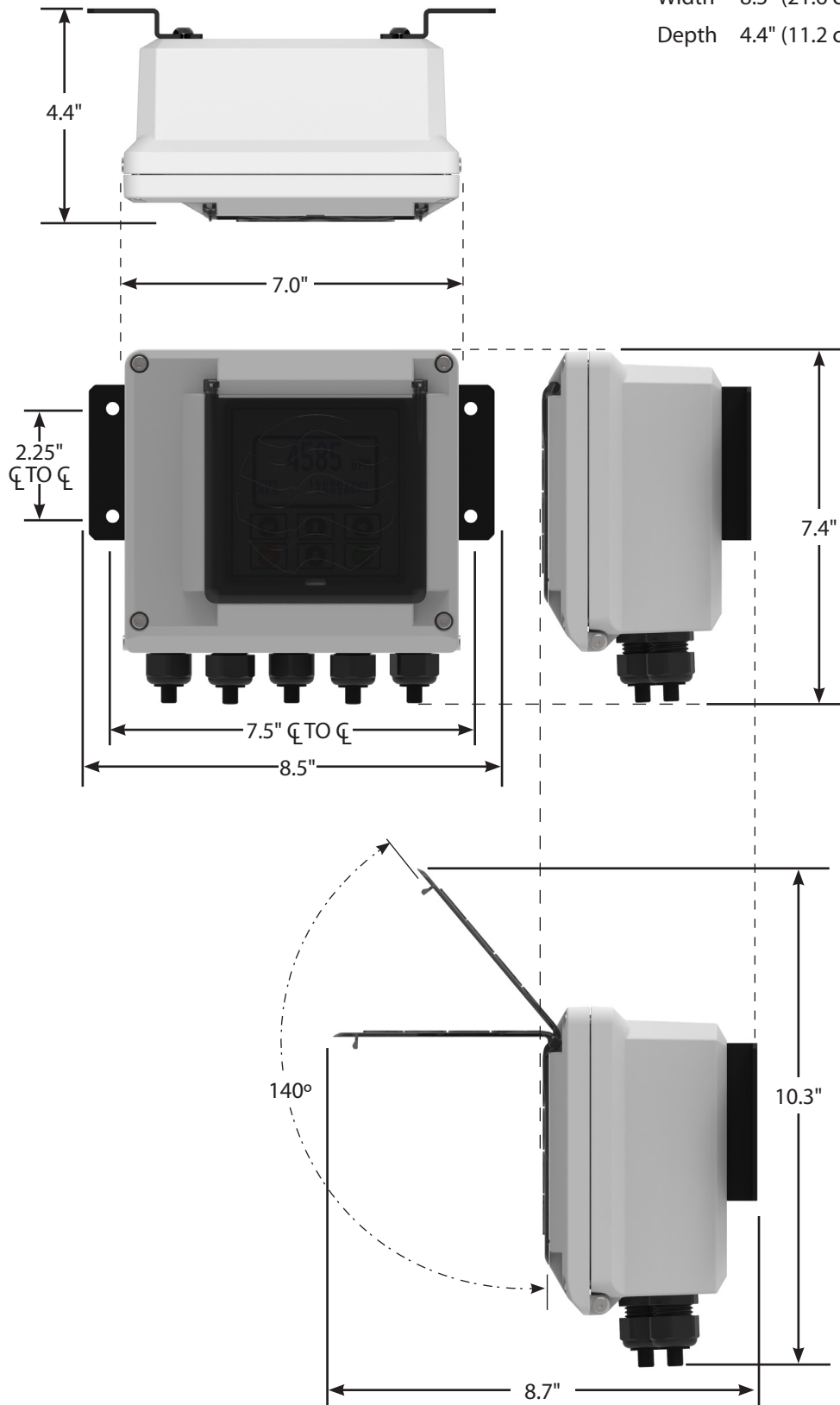
**Meter Mount Transmitter Dimensions**

Height 6.9" (17.6 cm)  
Width 7.4" (18.8 cm)  
Depth 5.6" (14.2 cm)



**Remote Mount Transmitter Dimensions**

Height 7.4" (18.9 cm)  
Width 8.5" (21.6 cm)  
Depth 4.4" (11.2 cm)



**11.0 ACCESSORIES AND REPLACEMENT PARTS**

Part Number	Description
<b>Transmitter and Display</b>	
XMTR-DISP	Transmitter Display Assembly
CON004	Transmitter Sun Shield Cover
<b>Power Cards</b>	
ELR751-AC	AC Power Card PCBBA
ELR752-DC	DC Power Card PCBA
<b>Daughter Output Cards</b>	
ELR754-RTU	RS485 Out Daughter Card PCBA Modbus
ELR755-HART	Hart/Dual 4-20 Out Daughter Card PCBA
ELR756-TCP	Ethernet Out Daughter Card PCBA
<b>Converter Boards</b>	
ELR740-CONV	Converter PCBA for UM, FM, VM, SPI, and Retrofit
ELR-741-FPI	Converter PCBA for FPI ProComm Max Design
<b>Strain Relief Cables</b>	
15050-25	25 foot prepped cable strain relief
15050-50	50 foot prepped cable strain relief
<b>Quick Connect Cables</b>	
MC-PC2-25-F	25 foot Quick connect Cable
MC-PC2-50-F	50 foot Quick connect Cable
MC-PC2-100-F	100 foot Quick connect Cable
MC-PC2-150-F	150 foot Quick connect Cable
MC-PC2-200-F	200 foot Quick connect Cable
MC-PC2-300-F	300 foot Quick connect Cable
MC-PC2-500-F	500 foot Quick connect Cable
MC-PC2-1000-F	1000 foot Quick connect Cable
<b>Standalone Remote Mount Transmitters</b>	
PC5-RA XX (See Smart Part Number for output options)	Remote Mount ProComm Max AC Power
PC5-RD XX (See Smart Part Number for output options)	Remote Mount ProComm Max DC Power
EA200-USB	USB Connection Cable 6ft USB A to Mini B Cable

## **12.0 RETURNING A UNIT FOR REPAIR**

If the unit needs to be returned to the factory for repair, please do the following:

- Prior to calling for a return authorization number, determine the model number, serial number (located inside the front panel of transmitter), and reason for return.
- Contact McCrometer Customer Service Department and ask for a Return Authorization (RA) number.
  - Telephone: 1-800-220-2279
  - Email: [customerservice@mccrometer.com](mailto:customerservice@mccrometer.com)
- Please make sure the meter is clean and free from foreign debris prior to shipping.
- Ship the meter in the original packaging, if possible. Do not ship manuals, power cords, or other parts with your unit unless required for repair.
- Write the RA number on the outside of the shipping box. All return shipments should be insured.
- Address all shipments to:
  - McCrometer, Inc.
  - RMA #
  - 3255 W. Stetson Avenue
  - Hemet, CA 92545

## **WARRANTY**

McCrometer warrants that this product will be free from defects in material and workmanship for a period 12 months from the date the equipment was first installed, but in no event longer than 18 months from the date the equipment was first shipped by McCrometer. Repairs shall be warranted for 12 months or, if the repair is performed under this warranty, for the remainder of the original warranty period, whichever is less.

Buyer shall report any claimed defect in writing to McCrometer immediately upon discovery and in any event, within the warranty period. McCrometer shall, at its sole option, repair the equipment or furnish replacement equipment or parts thereof, at the original delivery point.

McCrometer shall not be liable for costs of removal, reinstallation, or gaining access. If Buyer or others repair, replace, or adjust equipment or parts without McCrometer prior written approval, McCrometer is relieved of any further obligation to Buyer under this Article with respect to such equipment.

No equipment furnished by McCrometer shall be deemed to be defective by reason of normal wear and tear, failure to resist erosive or corrosive action of any fluid or gas (unless otherwise specified in Quotations/ Purchase Order Specifications), Buyer's direct or indirect failure (or the failure of its agents or contractors) to properly store, install, operate, or maintain the equipment in accordance with good industry practices or specific recommendations of McCrometer, or Buyer's failure to provide complete and accurate information to McCrometer concerning the operational application of the equipment.

**THE FOREGOING LIMITED WARRANTIES WITH RESPECT TO EQUIPMENT AND PRODUCTS ARE EXCLUSIVE AND IN LIEU OF ANY AND ALL OTHER WARRANTIES OF QUALITY OR PERFORMANCE, EXPRESS, IMPLIED OR STATUTORY, INCLUDING, WITHOUT LIMITATION, ANY AND ALL WARRANTIES OF MERCHANTABILITY OR FITNESS OF SAID EQUIPMENT AND PRODUCTS FOR ANY PARTICULAR PURPOSE.**

**MCCROMETER DISCLAIMS ANY WARRANTY, WHETHER EXPRESS OR IMPLIED, REGARDING THE SUITABILITY OF PRODUCTS AND EQUIPMENT SUPPLIED PURSUANT TO ANY PURCHASE ORDER FOR INSTALLATION IN ANY PARTICULAR SYSTEM OF SYSTEMS. MCCROMETER MAKES NO WARRANTY OF ANY KIND WITH RESPECT TO ANY SERVICES PERFORMED BY MCCROMETER OR ITS AGENTS PURSUANT TO ANY QUOTATION.**

Purchaser's sole remedy and manufacturer's sole obligation for alleged product failure, whether under warranty claim or otherwise, shall be the aforesaid obligation of manufacturer to repair or replace products returned within twenty-four months after date of original shipment. The manufacturer shall not be liable for, and the purchaser assumes and agrees to indemnify and save harmless the manufacturer in respect to, any loss or damage that may arise through the use by the purchaser of any of the manufacturer's products.

McCrometer does not authorize any person or entity (including, without limitation, McCrometer agents and employees) to make any representations (verbal or written) contrary to the terms of this limited warranty or its exclusions. Such terms of this limited warranty and its exclusions can only be effectively modified in writing and only by the President of McCrometer.

---

Copyright © 2024 McCrometer, Inc. All printed material should not be changed or altered without permission of McCrometer. Any published pricing, technical data, and instructions are subject to change without notice. Contact your McCrometer representative for current pricing, technical data, and instructions.

3255 WEST STETSON AVENUE • HEMET, CALIFORNIA 92545 USA  
TEL: 951-652-6811 • 800-220-2279 • FAX: 951-652-3078  
[www.mccrometer.com](http://www.mccrometer.com)

