

## Retrofit Instruction: From Water Specialties mechanical unit to FlowConnect unit, converting the drive shaft

### OVERVIEW OF THE PROCEDURE

This describes the procedure for retrofitting a Water Specialties mechanical flow meter to a FlowConnect unit. It requires replacing the mechanical register with a digital register, while converting the drive shaft from mechanical to electrical.

*This retrofit requires the flow meter to be completely removed from the pipe.*



**WARNING!**  
Never remove a meter or top plate assembly while the line is under pressure!

FROM

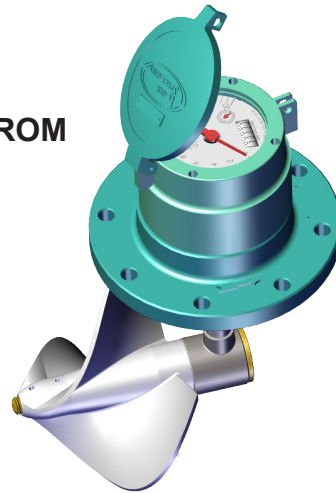

TO

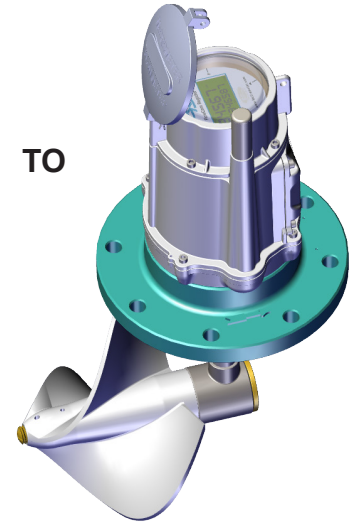

#### 1 - Retrofit Procedure

- STEP 1: Inventory the parts
- STEP 2: Remove the flow meter from the pipe
- STEP 3: Remove the totalizer assembly
- STEP 4: Remove the gearbox assembly
- STEP 5: Reassemble the gearbox assembly
- STEP 6: Remove the battery cover from the FlowConnect unit
- STEP 7: Remove the base plate from the FlowConnect unit
- STEP 8: Attach the FlowConnect base plate
- STEP 9: Attach desiccants packs in FlowConnect unit base plate
- STEP 10: Attach the FlowConnect unit to the base plate
- STEP 11: Attach the antenna
- STEP 12: Connect the batteries and attach the battery cover
- STEP 13: Attach the tamper evident seals
- STEP 14: Reinstall the flow meter in the pipe

#### 2 - Installing Sensors and Solar Panel

- 1: Recommended standards
- 2: Installing a solar panel
- 3: Installing a rain gauge
- 4: Installing a pressure sensor

#### 3 - Connecting Inputs and Outputs

- 1: Power connector
- 2: Inputs connector
- 3: Outputs connector

#### 4 - Setting the New FlowCom Register

- STEP 1: Enter PROGRAMMING MODE
- STEP 2: Cycle through the first menu level
- STEP 3: Cycle through the second menu level
- STEP 4: Set the total
- STEP 5: Exit and save settings



**WARNING!**  
Never remove a meter or top plate assembly while the line is under pressure!

## PARTS AND MATERIALS

Part Number	Description	Quantity
30122-21	IOM Manual	1
TOB008	WS Base Plate	1
TOB018	O-Ring for Base Plate	1
TOB050	#10-32 screw with O-ring	4
EJ539-00	Nylon cable fitting plug PG7	1
10735	O-ring 1.5 mm x 10 mm	1
TOB049	O-ring, wall mount bracket	1
15016-10	Tamper evident seals	3

Bagged items:

10015-00	Desiccant	2
10804	Cable tie	2
10790	#6 screw x 3/16" SS	2

1-1707-19	Terminal 2 position	1
1-1707-18	Terminal 1 position	1
	Antenna or antenna extension	1

## TOOLS REQUIRED

5/32" hex driver, T-shape wrench recommended  
 Phillips screwdriver  
 Standard flat head screwdriver  
 Precision flat head screwdriver  
 Wire cutter  
 Ratchet socket driver, 1/2" drive  
 1-3/8" socket

## LOCATION OF ACCESSIBLE COMPONENTS

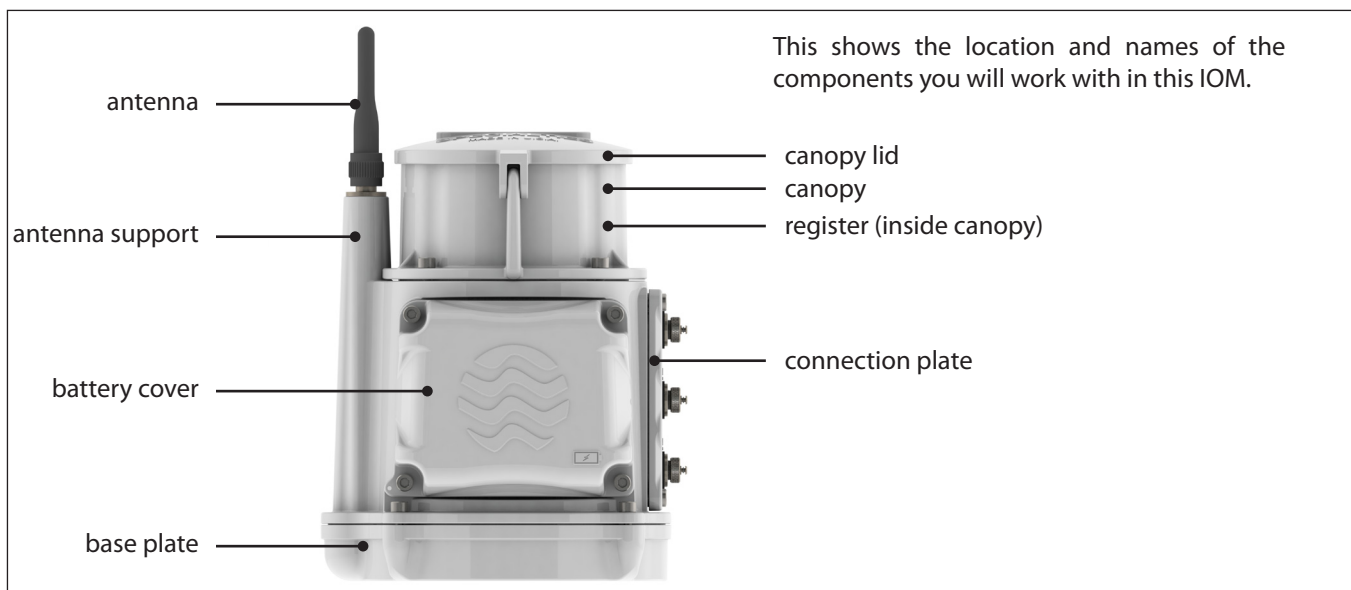

Figure 1. Accessible Components

## 1 - Retrofit Procedure

### STEP 1: Inventory the parts

- Check the parts received against the parts list on the previous page.
- Compare the serial numbers engraved on the lids to confirm they match.
- Confirm the serial number on the FlowConnect unit corresponds to information on a silver label located on the bottom of the base plate.

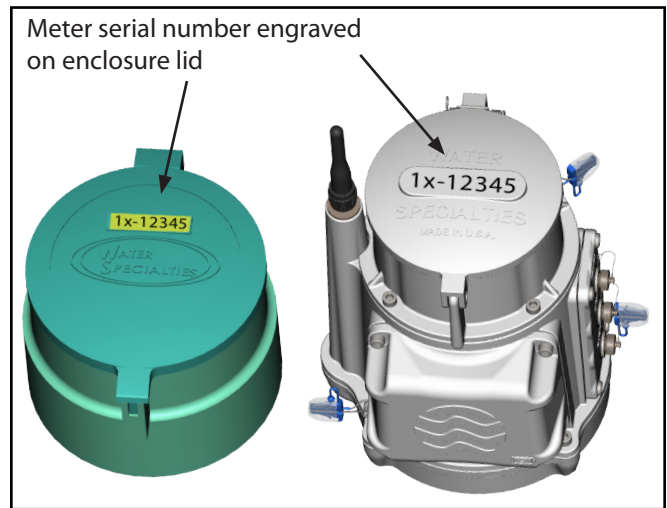

Figure 2. Checking engraved serial numbers on lids

### STEP 2: Remove the flow meter from the pipe

Remove the flow meter from the pipe as described in the Installation, Operation, and Maintenance (IOM) manual for Water Specialties Flow meters.

Remove pressure from the pipeline.

Remove the meter head assembly from the pipeline.



#### **WARNING!**

**Never remove a meter or top plate assembly while the line is under pressure!**

## STEP 3: Remove the totalizer assembly

Remove the entire totalizer or indicator-totalizer register assembly. Register models with totalizers have four bonnet screws and models with both the indicators and totalizers have four bonnet screws and two register screws. Remove the shaft.

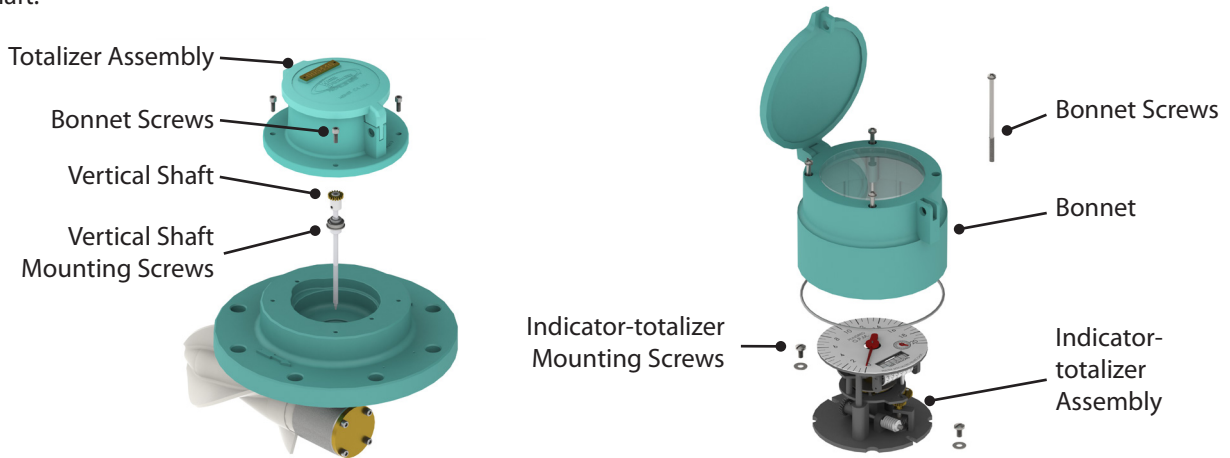

**For ML and LP meters:** Remove the V-shaft by loosening the two screws holding the V-shaft from the inside of the meter head.

**For ML and LP meters with extensions and for OF and VF meters:** Pull vertical shaft out only enough (approximately 1") for removal of miter gear frame assembly so that the vertical shaft can be used later for pulling the sensor input cable out of the drop pipe.

## STEP 4: Remove the gearbox assembly

**For ML, LP, and OF meters:** Remove the miter gear frame assembly by releasing the four screws out of the back of the gearbox.

**For VF meters:** Remove the propeller and the separator-spindle assembly.

**Caution:** The gearbox oil will begin draining as soon as the seal is broken.

Make sure the gearbox or drop pipe and separator/spindle assembly are dry and free of oil.

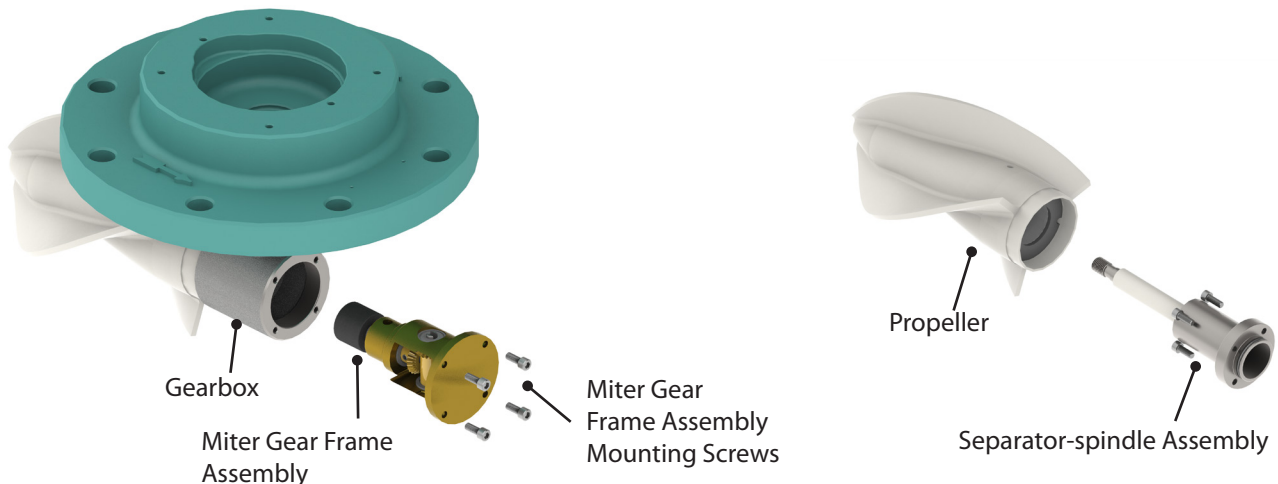

## STEP 5: Reassemble the gearbox assembly

**For ML and LP meters:** Push the sensor assembly through the back of the gearbox all the way into the separator/spindle assembly. Rotate the sensor assembly so that the sensor cable can be fed through gearbox up over the meter head. Put a thin film of silicon grease on the O-ring and secure the back plate of the gearbox with four screws.

Note: Do not twist the back plate. This can cause the O-ring to be pinched and the meter to leak.

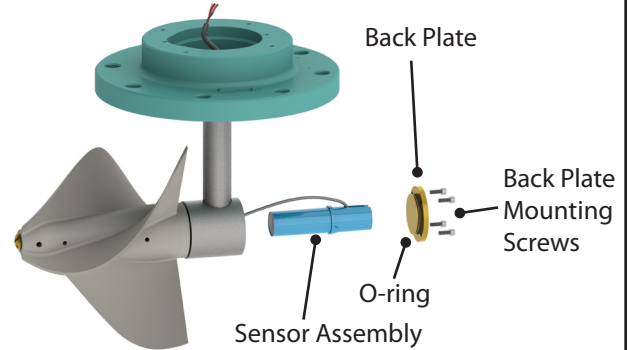

**For OF and 24" to 54" ML meters:** Attach pulling fixture T-2730-2 to bottom tip of existing vertical shaft assembly. Tighten both set screws on the fixture with a 0.062 Allen wrench for a secure connection to the vertical shaft tip. Loop sensor cable through hook on fixture and secure with a small piece of tape. Keep the sensor cable tight to allow passage through drop pipe bushings.

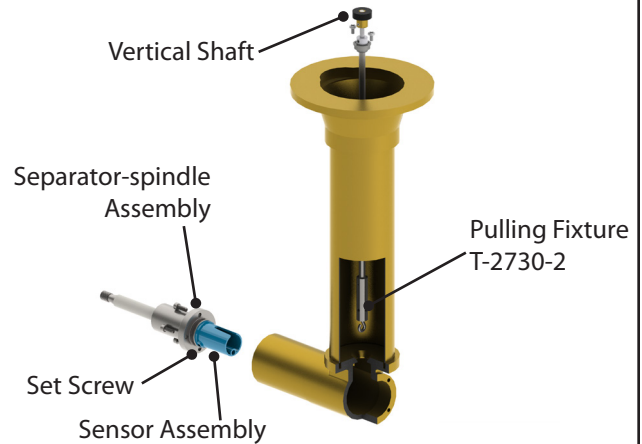

**For VF meters:** Push the sensor assembly all the way into separator/spindle assembly and then tighten the set screw to secure the position of the sensor assembly.

**Note:** The sensor cable must be positioned as shown.

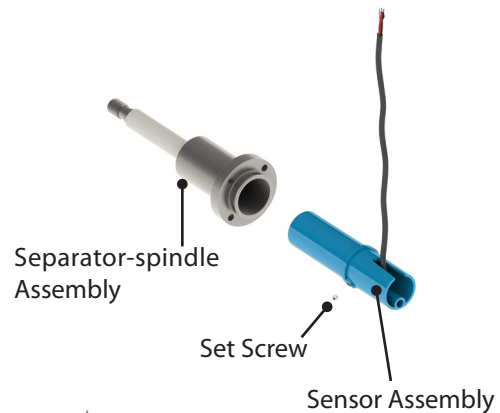

Then tie the sensor cable to the magnet end of the vertical shaft to assist in pulling the cable through. Leave approximately a 4" tale from the knot to the end connector so that magnet and cables can pass through the drop pipe end. At last, reinstall the propeller and separator/spindle assembly.



## STEP 6: Remove the battery cover from the FlowConnect unit

In order to attach the FlowConnect unit to the base plate, you **MUST** remove the battery cover. The screws for the base plate are not accessible when the battery cover is on.

To remove the battery cover, remove the four screws as shown below.

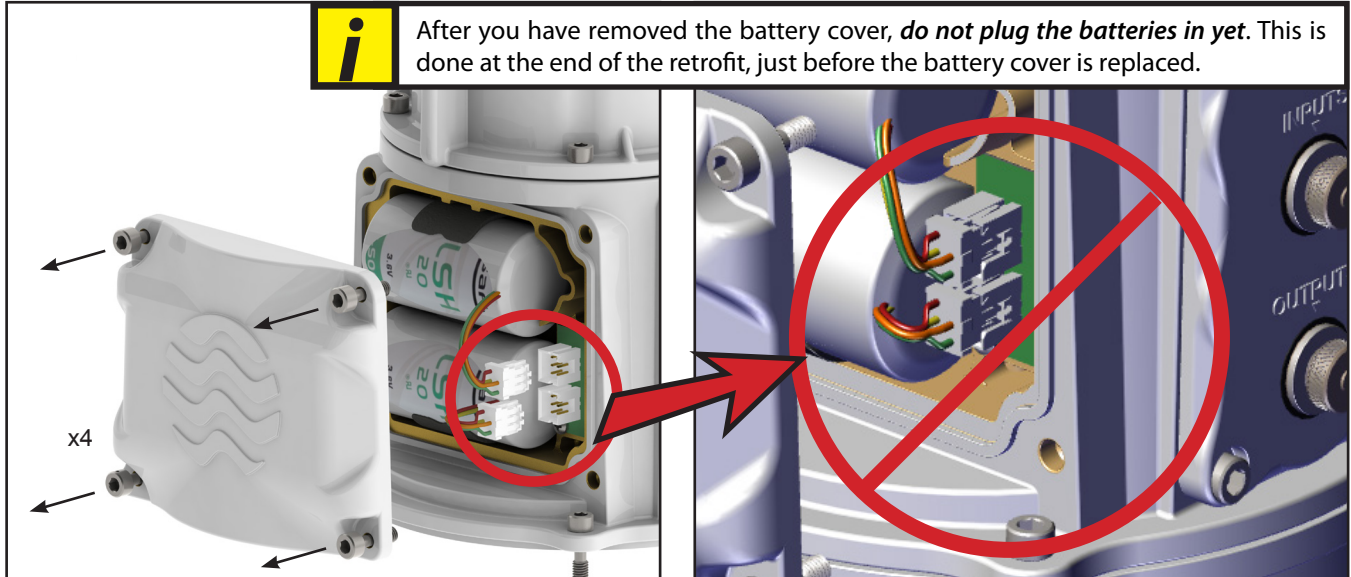

## STEP 7: Remove the base plate from the FlowConnect unit

Unscrew the four captive screws holding the body to the base plate and remove the base plate.

Set the FlowConnect unit body aside in a clean, dry place.

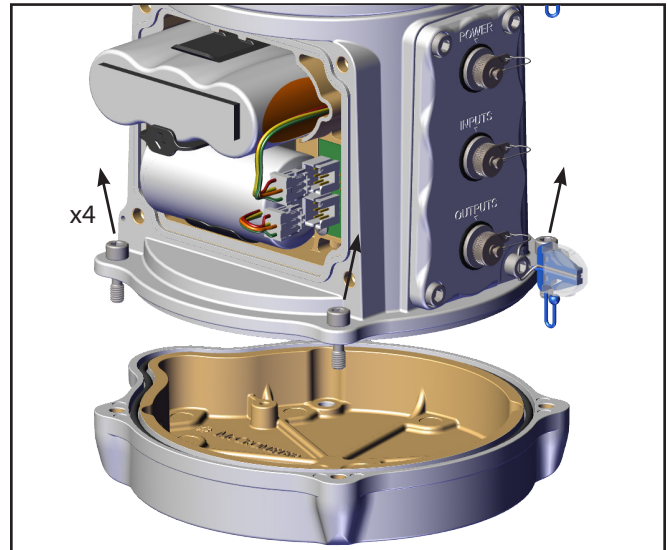

## STEP 8: Attach the FlowConnect base plate

- Set the O-ring and the FlowConnect base plate on the base plate as shown below.
- Align the FlowConnect base plate so that the nub is perpendicular to the direction of the flow.
- Attach the base plate with four screws.

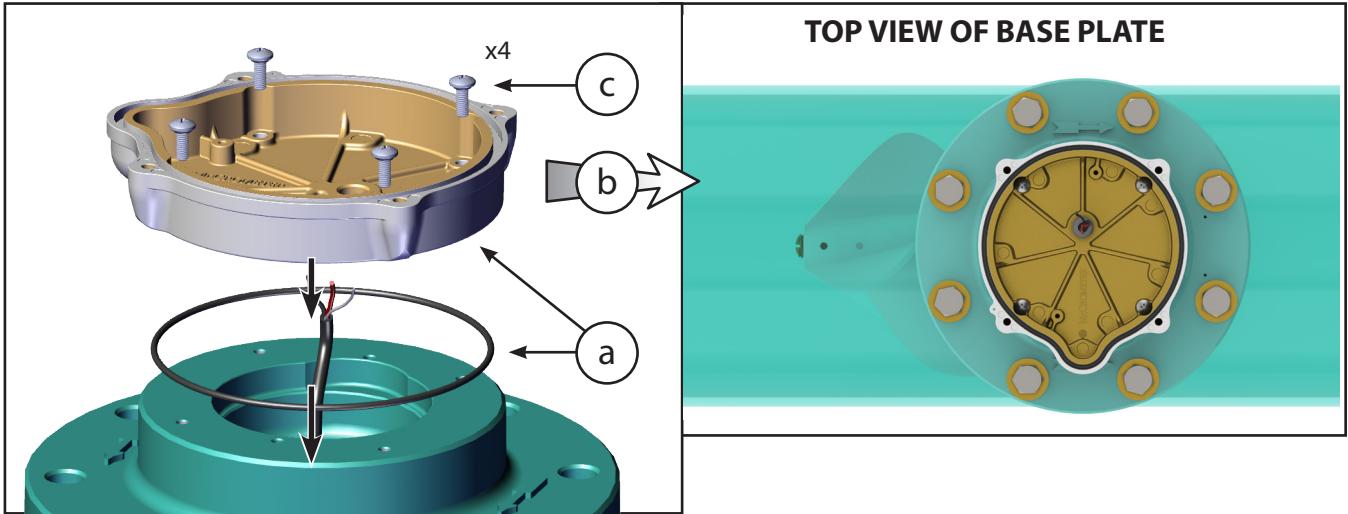

## STEP 9: Attach desiccant packs in FlowConnect unit base plate

Wrap and tighten a cable tie around two desiccant packs and screw them in place in the FlowConnect base plate.

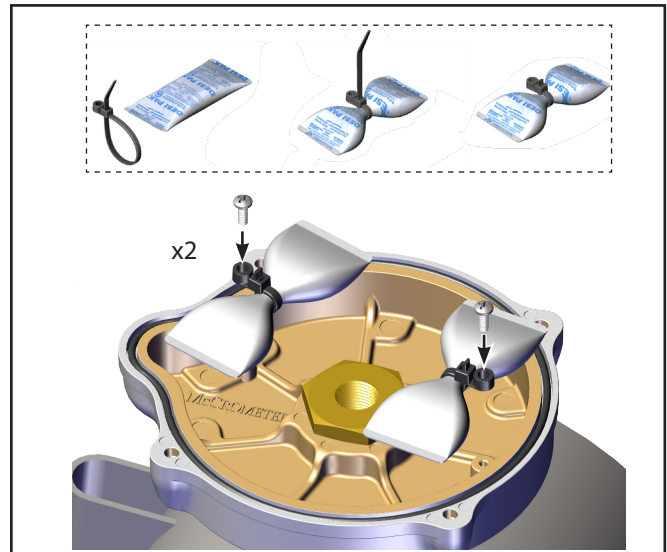

## STEP 10: Attach the FlowConnect unit to the base plate

- Connect the sensor wire to the in-line terminal block.
- Connect the cable from the FlowConnect unit to the in-line terminal block, matching the red, black, and green ground wires to the appropriate sensor cables.
- Making sure the O-ring is place flat and secure in the

groove, set the FlowConnect body on the base plate. Insert and tighten the four screws around the base of FlowConnect unit to secure it to the base plate.

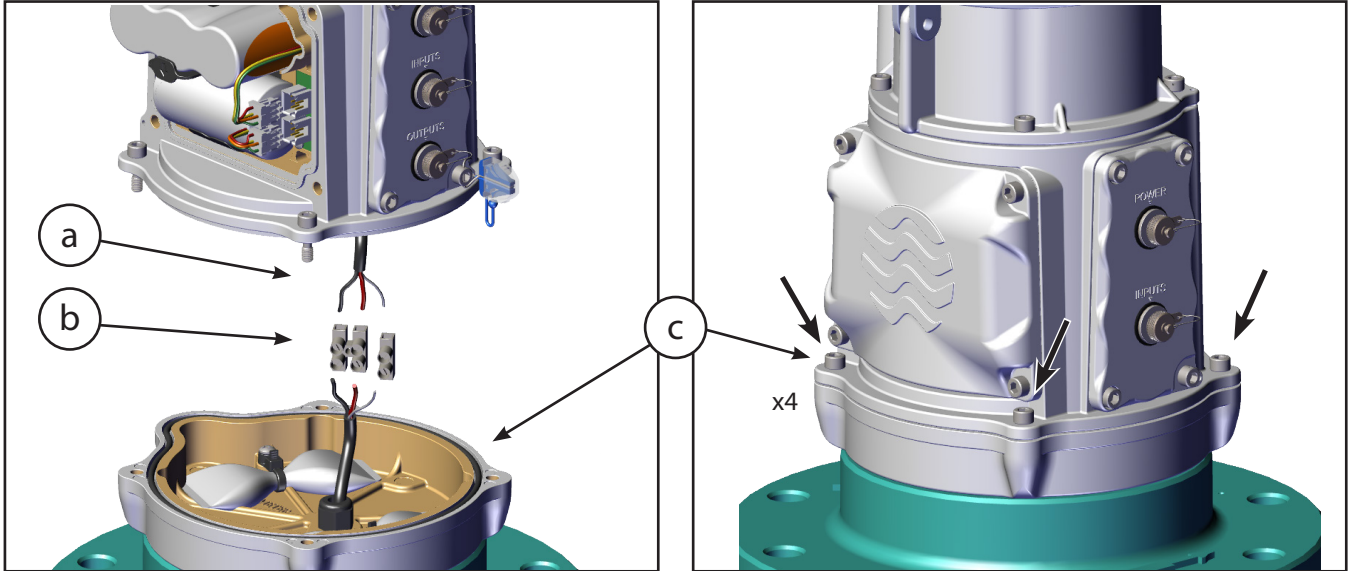

## STEP 11: Attach the antenna



**The antenna *MUST* be attached before the batteries are inserted! Powering up the unit without the antenna may damage the modem!**

Attach the cellular antenna or antenna extension by screwing it to the antenna post.



Figure 3. Attaching the cellular antenna

Figure 4. Attaching the satellite antenna

Figure 5. Attaching the antenna extension



### IMPORTANT!

To ensure good reception for the FlowConnect unit place it in an area that will ensure good coverage.

- FlowConnect Satellite should have view of the sky, especially the horizon.
- FlowConnect Cell should be in an area with good cellular coverage.

## STEP 12: Connect the batteries and attach the battery cover

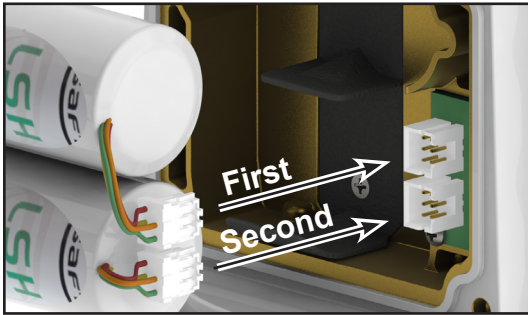

Figure 7. Non-rechargeable batteries

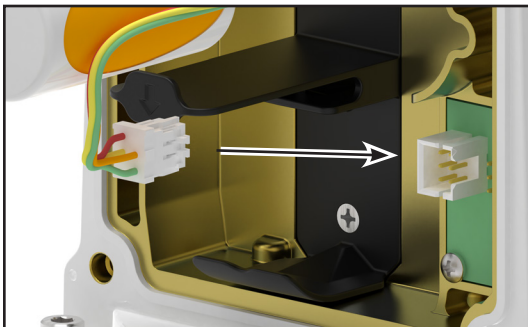
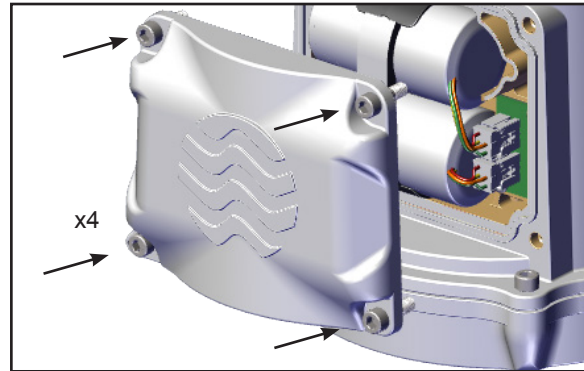

Figure 8. Rechargeable batteries

Non-rechargeable batteries must be connected in the order shown at left. Rechargeable batteries come as a single pack of three with one connector. Ensure the batteries are in place and plug the leads into the connectors in the order shown in Figure 7 and Figure 8.



When replacing the battery cover, make sure the O-ring is set in place flat and even, without any twisting.

Set the cover in position over the battery compartment. It will set easily in place. Tighten the four screws snug and hand tight.

## STEP 13: Attach the tamper evident seals

When the retrofit is completed, attach the three tamper evident seals located at:

- The canopy base
- The battery cover
- The base plate

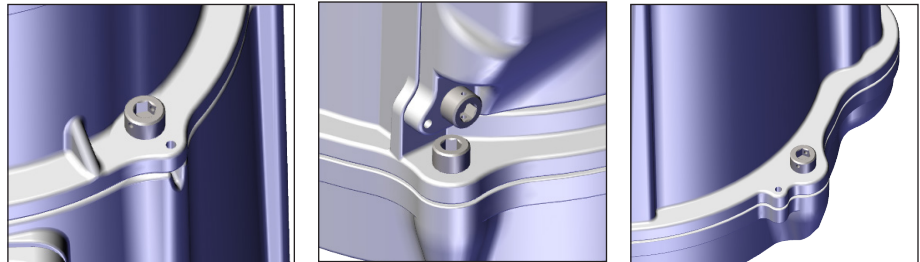

The tamper evident seal is attached through the hole in the security screw found at the bottom left corner of the battery cover.

1. Thread the wire end through the security hole near the battery cover and through the hole in the screw as shown in Figure 6.
2. Set the wire in the lock portion of the seal and close the clasp.

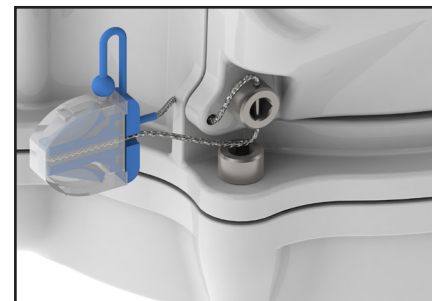

Figure 6. Tamper evident seal on battery cover

## STEP 14: Reinstall the flow meter in the pipe

Reinstall the flow meter in the pipe following Section 3.0 of the Installation, Operation, and Maintenance (IOM) manual for Mc Propeller Flow meters.

## 2 - Installing Sensors and Solar Panel

The method you use to install a sensor mount will depend on the sensor type and local site conditions. The site location for a pressure sensor, the aerial mast to mount a rain gauge, or the need for cable protection, may vary.

Because each user's requirements and conditions will vary, McCrometer does not require any particular way of mounting or securing the sensor pole. However, we do provide recommended standards for how your sensor mount should be installed. These standards are flexible enough to allow you to install your sensors under most conditions while being able to take into account your local circumstances.

### 1: Recommended standards

#### Pole set

You may choose to use the McCrometer pole set, or you may use a pole set more to your preferences.

#### Pole and aerial height

Height of 5' to 10', elevating an antenna 4' to 5' feet above surrounding obstructions.

#### Pole diameter

Any pole that is 1.25" to 2" in diameter will work with McCrometer sensors.

#### Solar panel orientation

If you are installing a solar panel, orient it so that it is facing south in the northern hemisphere.

#### Securing / anchoring

There are many ways to install and secure an aerial mast for a solar panel, rain gauge, or antenna extension. We recommend installing the mast plumb. The lower part of the mast may be buried or cemented into the ground, or it may be secured to surrounding fixed objects. The installation should be secure enough to withstand the expected environmental conditions (such as strong wind) as well as foot traffic at or near the installation site.

#### Cable protection

We recommend you consider cable protection for use against animals, foot traffic, or vehicle traffic around the installation site. Common methods include the use of metal or flexible conduit sufficient to accommodate the 1/2" connectors used on solar panels and sensor cables.

#### Cable management

It is recommended that you secure sensors or extension cables near any sharp metal edges such as hose clamps.

We also recommend securing cables about every 12" - 18" along the aerial mast.

#### Additional site protection

Some sites may require additional protection from damage from livestock or vandalism. Fencing, cattle guards, or other measures may be necessary.

### 2: Installing a solar panel

#### TOOLS AND MATERIALS

##### Tools and Materials:

Solar Panel kit (200.733.522 or 200.733.520)  
7 mm socket driver  
5-pin male to female extension cable

Use a hose clamp and 7 mm socket driver to attach the solar panel to the top of the pole.

Orient the solar panel south so that it gets a maximum amount of light.

Connect the extension cable to the solar panel. When you are finished, the other end of the cable will be plugged into the FlowConnect unit (see next section).

If you are also installing a rain gauge with a solar panel, they should be mounted on the same pole, directly opposite each other (Figure 9).

### 3: Installing a rain gauge

#### TOOLS AND MATERIALS

##### Tools and Materials:

Rain Gauge kit, model RG1  
7 mm socket driver  
7-pin male to female extension cable

Use a 7 mm socket driver and two hose clamps to secure the rain gauge to the top of the pole such that the mouth of the rain gauge is level with the end of the pole (Figure 9).

Connect the extension cable to the rain gauge. When you are finished, the other end of the cable will be plugged into the FlowConnect unit (see next section).

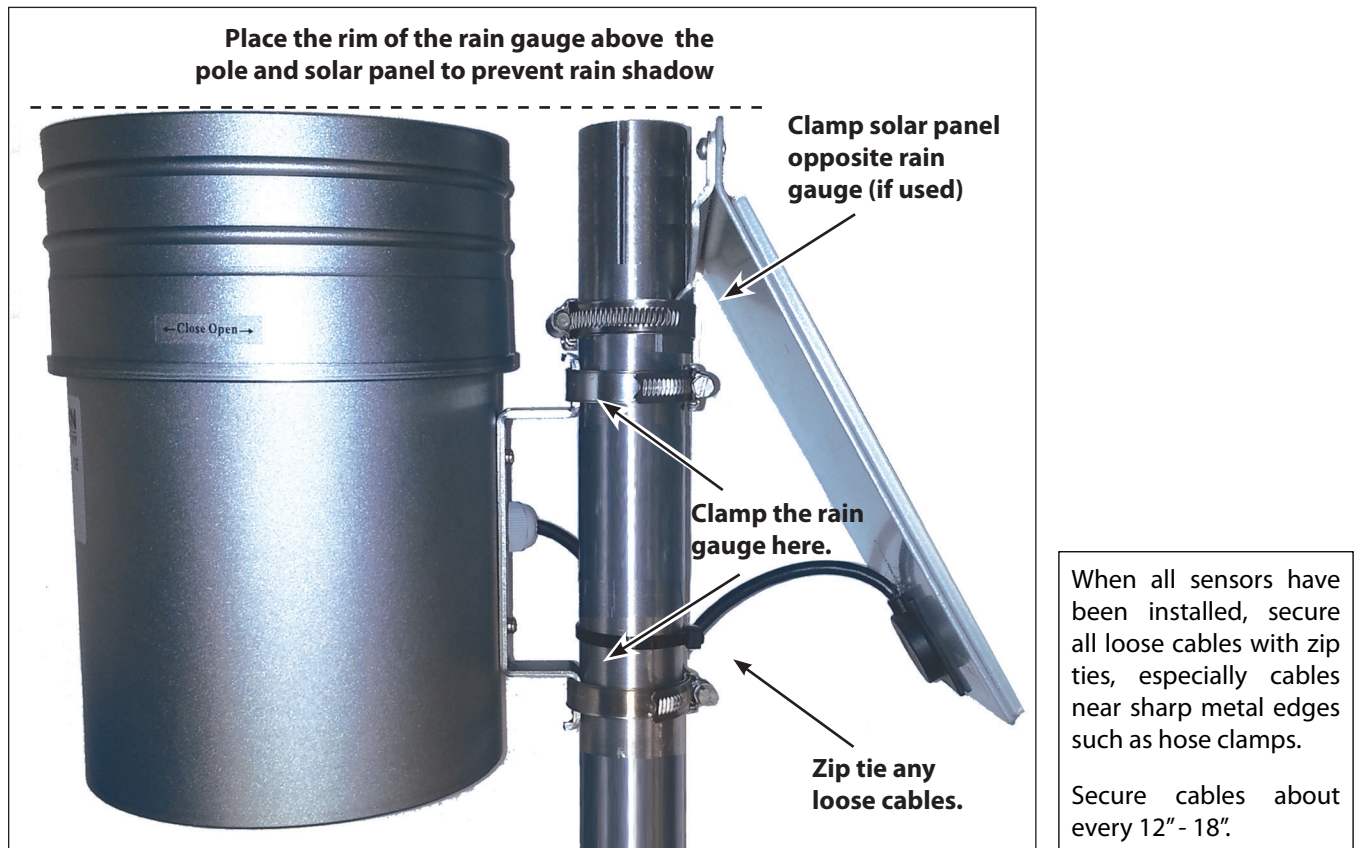

Figure 9. Solar panel and rain gauge attached to pole mount

## 4: Installing a pressure sensor

If you want to install a pressure sensor that can transmit measurement data to the FlowConnect unit, you will need the tools and materials listed at right.

This instruction is for a pipe that has an existing pressure gauge. If your pipe does not already have a location tapped and threaded, that will need to be done first. When completed, follow this instruction from step 2 below.

### TOOLS AND MATERIALS

**Note: Sensor parts are sold individually or as a bundle. The parts listed below are for sensor and cable bundles.**

PA-1 sensor and 10 m cable bundle (500.000.119) or

PA-1 sensor and 5 m cable bundle (500.000.120)

Cable for PA-1 pressure sensor

PA-1 pressure sensor 0-30 bar (200.733.162)

Crescent wrench or adjustable wrench

Channel locks (need to accommodate 3/4" pressure gauge)

Brass or steel wire brush



#### WARNING!

**Never remove a gauge while the line is under pressure!**

- Remove the existing gauge from the pipe.
- Clean the interior pipe threads and remove any debris.
- Wrap the pipe threads on the pressure sensor with Teflon tape.
- Screw in the pressure sensor by hand until it is tight, then use the channel locks to fully tighten it.
- Connect the extension cable to the pressure sensor.
- Coil and secure any extra sensor cable with zip ties to prevent cable from being damaged or becoming a hazard.

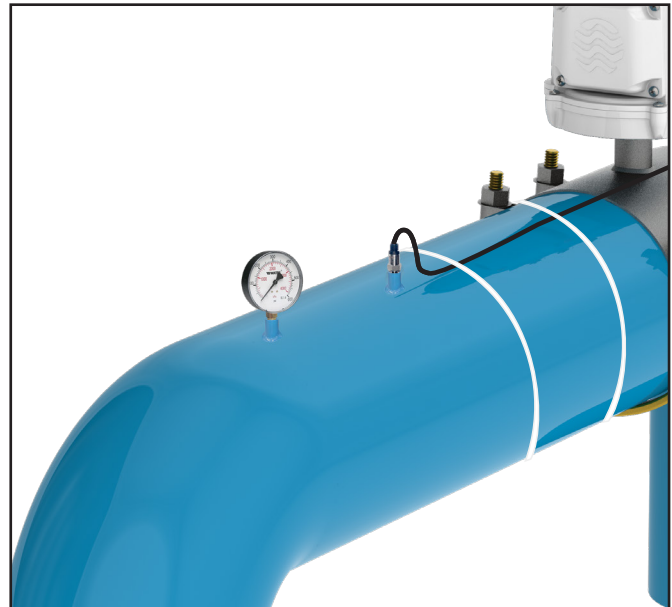
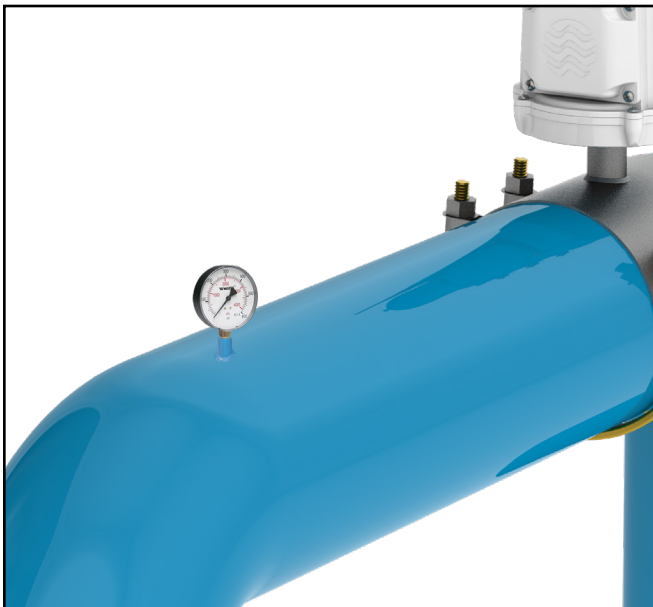

## 3 - Connecting Inputs and Outputs



### IMPORTANT!

Before purchasing any sensors, be sure to confirm that they are compatible with the FlowConnect system.

Figure 10 and Figure 11 below show possible methods of connecting inputs, outputs, and external power to the FlowConnect system. The examples in the figures show a FlowConnect with rechargeable batteries. If your system does not have rechargeable batteries, the connection plate will have only two connectors, Inputs and Outputs.

See the following page for discussion of the Power, Inputs, and Outputs connectors.

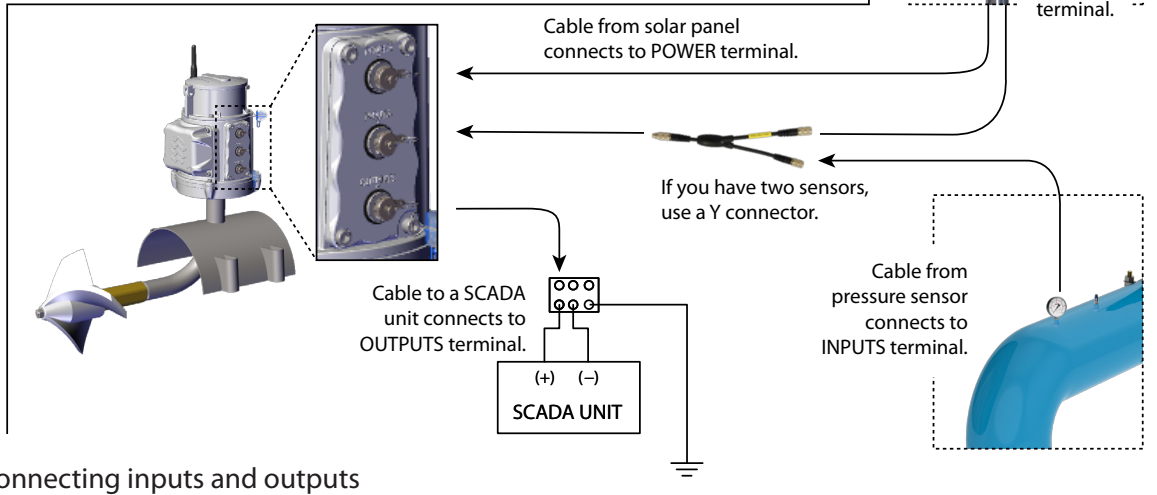
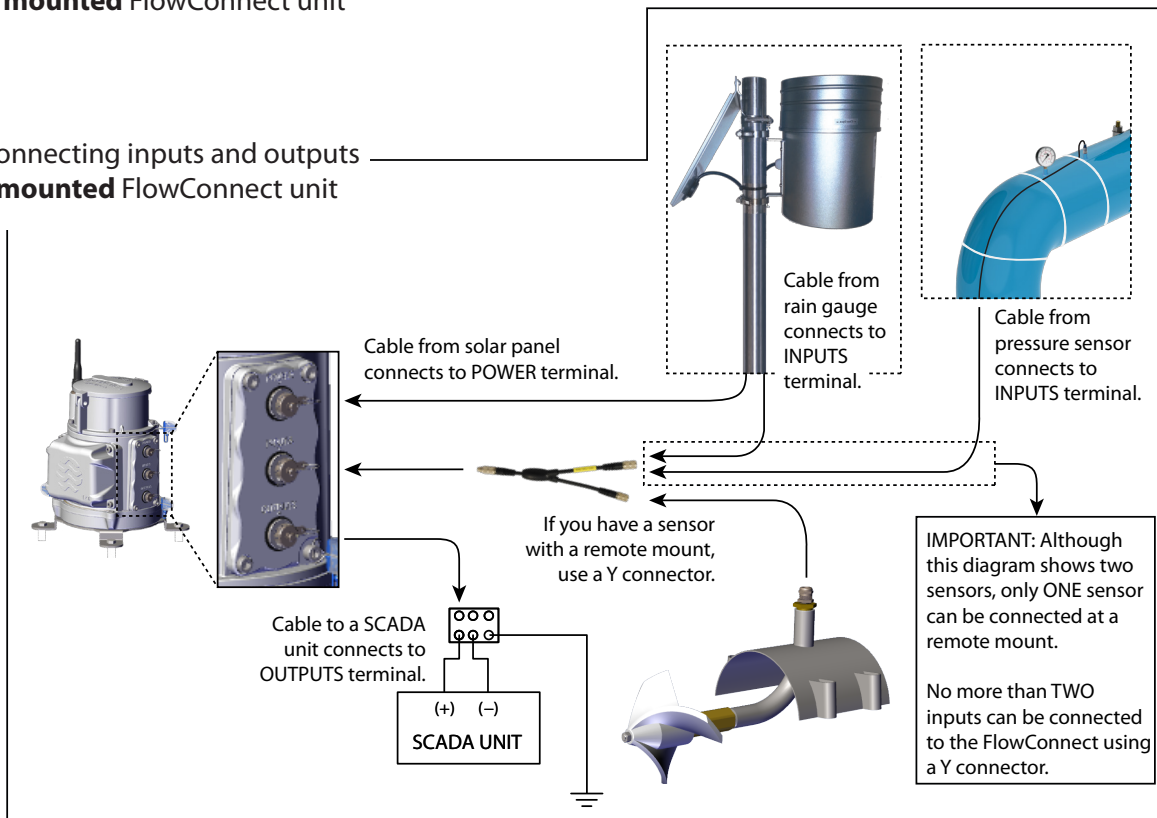

Figure 10. Connecting inputs and outputs to a **meter mounted** FlowConnect unit

Figure 11. Connecting inputs and outputs to a **remote mounted** FlowConnect unit



## 1: Power connector

For models with rechargeable batteries, a solar panel can be connected through the Power connector at the top of the connector plate.

## 2: Inputs connector

The FlowConnect unit supports up to two analog inputs through the Inputs connector. Inputs are most often sensors, such as a rain gauge or a pressure sensor. The Inputs connector will either be in the middle or at the bottom of the connector plate.

For simple configurations with just one sensor, plug the sensor directly into the Inputs port. To connect more than one sensor to the Inputs port, a Y-Cable (200.720.510) is needed. No more than two sensors can be connected at once, so only one Y-Cable is required.

## 3: Outputs connector

The Outputs connector is only available on FlowConnect models with a digital register. It provides 4-20mA and pulse output options. To enable the FlowConnect to send a 4-20mA or pulse output to another system, such as a SCADA system, an output cable (5M-025-OE) is required. If you choose to use this option, use the table below as a guide for wire colors:

Output Cable Wire Color:	Grey	Green	Brown	Yellow	White
<b>Open Collector Pulse Only</b>				Pulse (-)	Pulse (+)
<b>Optically Isolated Pulse and 4-20mA</b>	4-20mA (+)	4-20mA (-)		Pulse (-)	Pulse (+)
<b>Relay Pulse and 4-20mA</b>	4-20mA (+)	4-20mA (-)	Normally Closed	Common	Normally Open

## 4 - Setting the New FlowCom Register

### Brief explanation of why this is necessary:

After a FlowCom unit has been replaced with a new FlowConnect unit, users may want to set the register with the total gallons amount from the previous register. The instructions below are a concise guide to programming and resetting the total gallons only.

See the FlowCom IOM for complete procedures and description of FlowCom programming and features.

### What this procedure will help you do:

As shown by the example at right (Figure 12), you will be able to change the total on the register that appears during normal operation.

This procedure will show you how to change the total from **0** to **12345**.

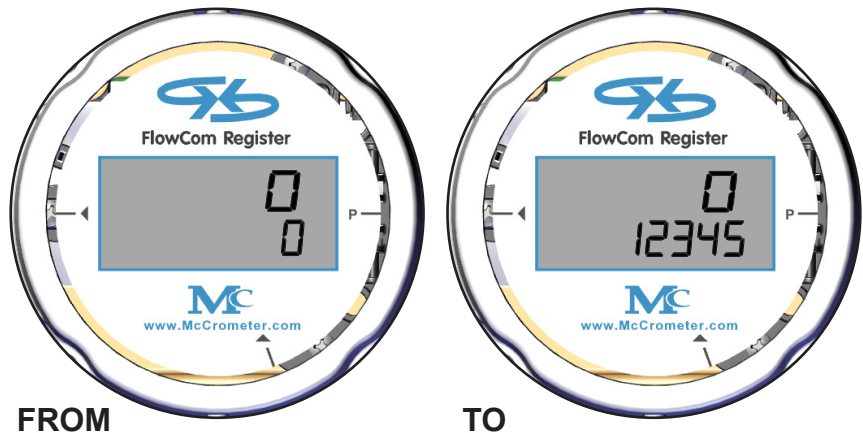

Figure 12. Example register totals



### WARNING!

It is very important that each step is followed carefully! If you do not feel confident programming the FlowCom register, we strongly recommend contacting a service technician.

While these instructions are streamlined for just the programming function required, if you find you made an error in and cannot back out of the menus, follow the "RECOVERY FROM ERROR" procedure.

**RECOVERY FROM ERROR**

It is possible to make a wrong selection when programming the FlowCom register. If this happens, you can recover from the error by doing the following:

Cycle through the menu selections

- If you remember the original value, cycle through all of the values until you come to the selection you want.

Time out the programming mode

- If you can't find the value you want or find the menu you need, allow the programming mode to time itself out. This is done by making no selections or changes while the digital display is still flashing and waiting about 30 - 60 seconds.

There are three activation points located on the outside of the register that are used to access the configuration menu as shown in Figure 13:

- The **P** on the far right side is used for accessing and navigating through the programming menu.
- The ▲ arrow at the lower right side is used for incrementing flashing selections.
- The ◀ arrow at the far left side is used for moving to the next flashing selection.



Figure 13. Magnetic wand activation points for configuration menu

## STEP 1: Enter PROGRAMMING MODE

- Hold the magnetic wand at the **P** on the right side of the register. After five seconds the register will display "Loc-codE" (Figure 14). The last digit will flash.

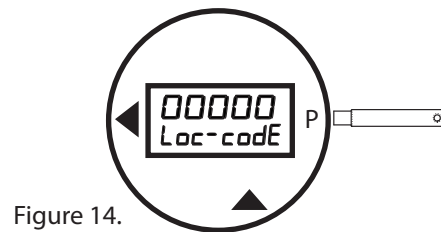

Figure 14.

- Pass the wand on the ◀ three times. The second digit from the left will flash (Figure 15).
- Pass the wand on the ▲ once. The display will increment from 0 to 1 (Figure 15).

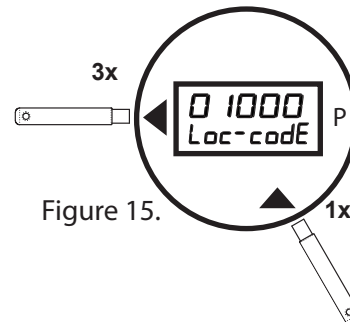

Figure 15.

**A lock code of 01000 is required to enter the configuration menu.**

- Pass the wand over the **P** to enter the lock code. The menu selection **rAtE-Un** will appear (Figure 16). This is the first item in the first menu level.

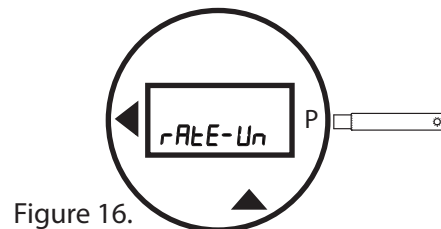

Figure 16.



**IMPORTANT:** Be careful not to change any settings as you cycle through the menu selections. If you accidentally make any changes, **stop immediately**, wait until the configuration mode times out, and start over.

## STEP 2: Cycle through the first menu level

The first level menu selection appear in the order shown in the table at right.

- Pass the wand over the **P** until you reach the **L1 -Go to** menu selection (Figure 17).

If you pass it by, the menu selections will start again from the beginning.

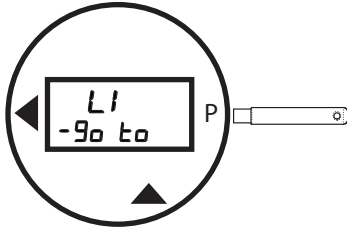

Figure 17.

- Pass the wand over the **▲** once. The selection will advance to **L2 -Go to** (Figure 18).

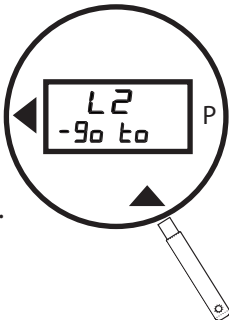

Figure 18.

- Pass the wand over the **P** once to advance to the second menu level. The selection **PAR-S** with the meter's serial number will appear (Figure 19). This is the first item in the second menu level.

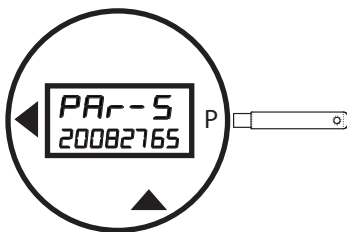

Figure 19.

First Menu Level		
Display	Menu Title	Description
Loc-CodE	Program Lock Out	Enter w/ preset code
rAtE-Un	Rate Unit/Time	Sets Unit/Time
rAtE-dP	Rate Format	Sets Rate Decimal Place
tot-Un	Totalizer Unit	Sets Unit
* tot-dP-E	Totalizer Decimal Point Enable	Enables/Disables Totalizer Decimal Point
* tot-dP	Totalizer Decimal Place	Sets Decimal Place
* Tot-FACT	Totalizer Multiplier	Sets Multiplier
20mA-Un	20mA Unit	Sets 20mA Unit
20mA-dP	20mA DP	Sets 20mA Decimal Place
20mA-FS	20mA FS	20mA Full Scale
PLS-Un	Pulse Unit	Sets Pulse Unit
PLS-dP	Pulse Decimal Place	Sets Pulse Decimal Place
PLS-Inc	Pulse Increment	Sets Pulse Value
CAL-Pct	Calibration Percent	Adjusts Meter Accuracy
L1 -Go to	Go to Second Menu Level or Run	

\* These menu items are controlled by the tot-dP-E setting. Depending on its setting, either tot-dP or Tot-FACT will appear, but not both.

### STEP 3: Cycle through the second menu level

The second level menu selection appear in the order shown in the table at right.

- Pass the wand over the **P** until you reach the **tot-S** menu selection (Figure 20).

If you pass it by, the menu selections will start again from the beginning.

The number shown in the configuration menu will be 00000000 and not the total gallons the appears on the register during normal operation.

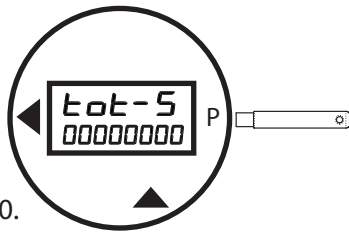

Figure 20.

### STEP 4: Set the total

- Pass the wand over the **◀** to move and activate each digit (Figure 21).

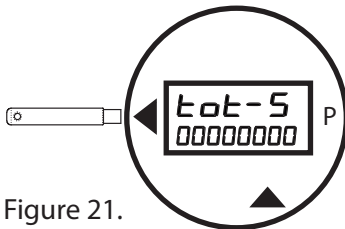

Figure 21.



Note: The flashing digits will activate from right to left.

- As each digit is activated, pass the wand over the **▲** to increment to the desired number (Figure 22).

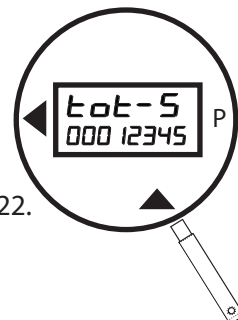

Figure 22.

Second Menu Level		
Display	Menu Title	Description
Par-S	Parent Meter Serial #	Sets Meter Serial No.
SErno	Register Serial #	Sets Register Serial No.
Set-CodE	Set Lock Code	Sets new Lock Code
GPr-dP	GPR Decimal Place	Sets GPR Decimal Place
GPr	Gallons Per Revolution	Sets GRR Digits
Smooth	Smoothing	Turns Smoothing on/off
4mA-AdJ	Trim 4mA	Adjusts 4mA Zero
20mA-AdJ	Trim 20mA	Adjusts 20mA FS
PLS-tYPE	Pulse Type	Sets Pulse Type
PLSwidth	Pulse Width	Sets Pulse Width in ms
RESEttot	Reset Total	Zeroes Total
* DIS-rSt	Disable Reset Total	Permanent Reset Disable <b>SEE NOTE BELOW</b>
tot-S	Set Total	Sets Total
Au-InP	Auxiliary Input	Sets operation of input
cutoff	Low Flow Cutoff	Sets Min. Flowrate
PLS-Pr	Pulses per Revolution	Sensor Pulses per rev.

L2 -Go to Go to First Menu Level or Run

rUn -Go to

SET

### EXTREMELY IMPORTANT!



**Do not change the setting for the menu selection DIS-rSt!**

If this is set to "YES", you will not be able to change or reset the totalizer.

This will permanently change the menus and can only be corrected by returning the unit to the factory to have the firmware reflashed.

Disable Reset Total

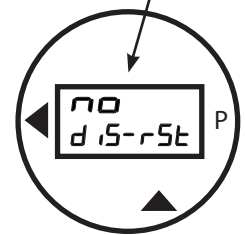

## STEP 5: Exit and save settings

Note: If you do not save your settings and allow the configuration mode to time out, your settings will be lost.

- a. Pass the wand over the **P** until you reach the **L2 - Go To** selection (Figure 23).

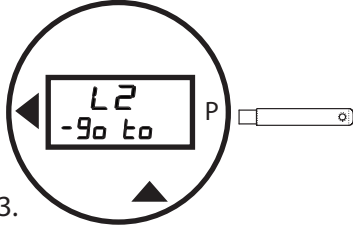

Figure 23.

- b. Pass the wand over ▲ to increment to the **rUn - Go** selection (Figure 24).

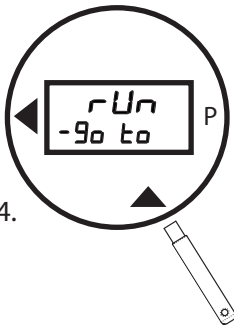

Figure 24.

- c. Pass the wand over **P**. This will end configuration mode and save your changes (Figure 25).

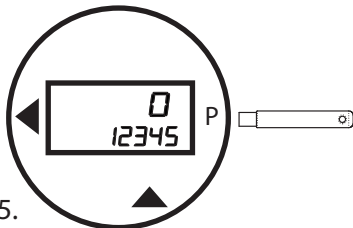

Figure 25.

NOTE: At the **L2 - Go To** selection, if you pass the wand over **P** to move to the second menu level, the selection **rUn - Go to** will appear. Then if you make a second pass over **P**, any changes made will be set.

