



**ULTRA MAG™ 3000**  
ELECTROMAGNETIC FLOW METER  
WITH PROCOMM GO TRANSMITTER

SUBMITTAL PACKAGE

From

McCROMETER  
3255 WEST STETSON AVENUE  
HEMET, CA 92545

Phone (951) 652-6811  
Toll Free (800) 220-2279  
Fax (951) 652-3078

[www.mccrometer.com](http://www.mccrometer.com)

Date:

Project Name:	
Purchase Order No.:	
Date:	
Customer Name:	
Submitted By:	
Other Project Information:	

When completing this submittal package, it must also include the Muni Mag Meter Part and Price Configurator, which is also an electronic document. A version without pricing can be downloaded from the McCrometer web site with the following link.

[Muni Mag Part and Price Configurator](#)

The Muni Mag Meter Part and Price Configurator is a macro-enabled Excel spreadsheet that contains multiple drop down fields for multiple product configurations. After it is filled out, save the spreadsheet under a different name and submit the file with the submittal package.

You can request a version of the Configurator with pricing by contacting McCrometer Customer Service or Inside Sales. Their contact information is on the McCrometer Web site.

See the following specification sheet and drawings for sizing and option details.

PART NUMBER	DESCRIPTION	METER 1 QTY.	METER 2 QTY.	METER 3 QTY.
<b>Standard Equipment</b>				
Ultra Mag Flow Meter				
	Standard meter			
	Hazardous location meter			
	ProComm Go Transmitter <ul style="list-style-type: none"> <li>• Battery power standard</li> <li>• Two digital pulse outputs</li> <li>• Data logger</li> </ul>			
<b>Notes on standard equipment on Ultra Mag flow meters:</b> <ul style="list-style-type: none"> <li>• UltraLiner™ technology with NSF fusion bonded epoxy coating</li> <li>• Stainless Steel Electrodes</li> <li>• 2-Year Warranty</li> </ul>				
<b>Sensor Options</b>				
	Flanges			
	Additional sensor cable: Specified total length in feet (leave blank for none)			
Special	Compression Gland Seals (instead of Quick Connects at sensor)			
<b>Transmitter Options</b>				
	Power Options	10 to 35 VDC		
		100 to 240 VAC		
	Communications Options (select all that apply)	SmartTrax		
		AMI Smart Output (Sensus, Itron 6, Itron 9)		
	Output Option	4-20mA (passive)		

**Project Notes**

Meter 1:

Meter 2:

Meter 3:

## **Contents**

<b>Ultra Mag</b> .....	<b>5</b>
Suggested Specifications .....	5
Product Specifications.....	9
Flow Meter Dimensions .....	11
Part Number Matrix .....	13
Sensor Grounding and Electrical Interference .....	16
<b>ProComm GO Transmitter</b> .....	<b>17</b>
Transmitter Specifications .....	17
Transmitter Dimensions .....	19
Transmitter Cable Connections from Sensor.....	20
Battery Installation and Connection.....	22

## **Suggested Specifications**

### **PART 1 - GENERAL**

#### **1.1 SCOPE**

This section describes the requirements for an electromagnetic flow meter and microprocessor-based signal transmitter. Under this item, the contractor shall furnish and install the mag meter equipment and accessories as indicated on the plans and as herein specified.

#### **1.2 SUBMITTALS**

The following information shall be included in the submittal for this section:

1. Data sheets and catalog literature for the magmeter and the microprocessor-based signal transmitter.
2. Connection diagrams for equipment wiring.
3. List of spare parts and optional equipment.

### **PART 2 - PRODUCTS**

#### **2.1 ELECTROMAGNETIC FLOWMETER (MAG METER)**

The electromagnetic flow meter shall consist of a flow sensor based on Faraday's Law of Electromagnetic Induction and microprocessor-based signal transmitter.

##### **A. Sensor:**

1. Operating principle: Utilizing Faraday's Law of Electromagnetic Induction, the flow of liquid through the sensor induces an electrical voltage that is proportional to the velocity of the flow.
2. Construction:
  - a. The sensor flow tube shall be NEMA 6P or IP68 rated.
  - b. Flow tube shall be constructed of 304 Stainless Steel.
  - c. The liner material shall be Ultra Liner NSF approved fusion bonded epoxy. The liner shall carry a lifetime guarantee.
  - d. Measurement and grounding electrodes shall be 316 Stainless Steel.
    - 1) Optional: Hastelloy C276 Electrodes shall be available for when corrosive fluids are present.
  - e. Connecting flanges shall be AWWA 150# (Optional 300# service shall be available) Flat Face Carbon Steel.
3. ANSI Flanges shall be available when required.
4. Two Stainless Steel grounding rings shall be supplied with each flow meter.
5. Installation:
  - a. A minimum of 0 pipe diameters up stream and 0 pipe diameter downstream are recommended for sizes 1.5" – 3"
  - b. A minimum of 2 pipe diameters up stream and 1 pipe diameter downstream are recommended for sizes 4" – 24"

## Suggested Specifications

6. Flow tube Operating Temp: +14 to +140° F.
7. Size: 1.5" to 24" diameter
8. Submergence: The sensor shall be capable of continual submergence at up to 6 ft. with optional quick connect cabling system.
- B. Transmitter:
  1. Electronic Enclosure: Shall be a NEMA 4X, IP67 rated enclosure.
  2. Transmitter/display: Transmitter shall be microprocessor based and shall have the following:
    - Non-volatile memory
    - Anti-reverse totalizer (standard)
    - Total (to 9 digits of precision)
    - Flow Rate and Velocity (to 5 digits of precision)
    - Two alarms: low battery and empty pipe (optional)
  3. 2-line LCD display (no backlight), 16 characters per line
  4. Power supply:
    - a. 90-265 VAC
    - b. 10-35 VDC
    - c. Battery
    - d. Battery-solar
  5. Operating temperature: -4 to +140 degrees F.
  6. Outputs:
    - a. 4-20 mA (passive)
    - b. Two separate digital programmable outputs:
      - 1) Open collector transistor usable for pulse
      - 2) Frequency and alarm settings
  7. Communications-Optional:
    - a. AMI Smart Output (Sensus, Itron 6, Itron 9).
  8. Transmitter Self Diagnostics –Data logger and Alarms
  9. Manufacturer shall provide an optional Hazardous Location certified model. Certified by MET to UL 6100-1 and MET C22.2 No. 61010-1-04
    - a. Class I, Division 2, Groups A B C D, T4
    - b. Class I, Zone 2, IIC T4
  10. Sensor and signal transmitter performance:
    - a. Flow Range: .2 FPS to 32 FPS for accuracies stated below.
    - b. Accuracy:
      - 1) Plus or minus 1% of actual flow
    - c. Cable Length: Remote Mount
      - 1) Up to 25'/7.6m

## **Suggested Specifications**

- d. Manufacturer shall offer optional Quick Connect cabling for remote mounted installations.
- e. Repeatability:  $\pm 0.05\%$  or  $\pm 0.0008\text{ft/s}$  ( $\pm 0.25\text{mm/s}$ ), whichever is greater
- f. Conductivity: Minimum  $5\ \mu\text{s/cm}$
- g. Optional meter mounted transmitter.
- h. Bi-directional flow capabilities shall be standard.
- i. Flow Direction Measurement: Forward and reverse flow indication and forward, reverse, net totalization is standard on all meters.

11. The electromagnetic flow meter shall be a McCrometer Ultra Mag or approved equal.

### **2.2 SPARE PARTS**

A. Spare parts for the equipment shall include the following, unless otherwise noted:

- 1. Extra operation manuals as required.

### **2.3 OPERATOR FUNCTIONS**

A. Calibration

- 1. Each flow sensor shall have a 3 or 5- point wet flow calibration of the complete meter flow tube and its signal transmitter. The calibration facilities must be traceable to the National Institute of Standards and Technology (N.I.S.T). All the calibration information and factory settings matching the sensor shall be stored in an integrally mounted memory unit. The memory unit shall store sensor calibration data and signal transmitter settings for the lifetime of the product. At initial commissioning, the flow meter commences measurement without any initial programming. Any customer specified settings are downloaded to the memory unit. Should the signal transmitter need to be replaced, the new signal transmitter will upload all previous settings and resume measurement without any need for reprogramming or rewiring.
- 2. Manufacturer shall provide a calibrated meter set which includes the sensor tube, the cabling and the transmitter.
- 3. An N.I.S.T. certificate of calibration shall accompany each flow sensor.

## **PART 3 - EXECUTION**

### **3.1 INSTALLATION**

- A. Follow manufacturer's recommendation for the minimum upstream and downstream installation requirements for the flow sensor.
- B. Wiring between flow sensors and remote mounted signal transmitters shall use cable type and procedures as per the manufacturers' recommendations.

## ***Suggested Specifications***

### **3.2 MANUFACTURER'S ASSISTANCE**

#### A. Warranty

1. The manufacturer of the electromagnetic flow meter shall provide a two-year warranty that the equipment shall be free from defects in design, workmanship, or materials. Extended warranties up to five years shall be available for additional cost.
2. The manufacturer of the electromagnetic flow meter shall provide a Lifetime Guarantee on the flow tubes Ultra Liner fusion bonded epoxy liner.
3. In the event a component fails to perform as specified or is proven defective in service during the guarantee period, the manufacturer shall promptly repair or replace the defective part at no cost to the owner.

## Product Specifications

All specifications apply to both Ultra Mag 3000 and Ultra Mag 5000 models except where noted.

### Physical Specifications

<b>Measurement Method</b>	Electromagnetic flow based on Faraday's Law
<b>Directionality</b>	Forward and reverse flow indication and forward, reverse, net totalization are standard with all meters
<b>Pipe Sizes</b>	Ultra Mag 3000: 1½, 2", 2½, 3", 4", 6", 8", 10", 12", 14", 16", 18", 20", 24" Ultra Mag 5000: 1½, 2", 2½, 3", 4", 6", 8", 10", 12", 14", 16", 18", 20", 24", 30", 36", 42", 48"
<b>Body Style</b>	Flanged tube
<b>Liner</b>	206N
<b>Electrodes</b>	Type 316 stainless steel, Hastelloy optional
<b>Electrode Shape</b>	Standard shape
<b>Electrical Connections</b>	<ul style="list-style-type: none"> <li>• Compression gland seals</li> <li>• Quick-Connect</li> </ul>
<b>Signal Transmitter</b>	<ul style="list-style-type: none"> <li>• Ultra Mag 3000: ProComm GO transmitter</li> <li>• Ultra Mag 5000: ProComm Max transmitter</li> </ul>
<b>Transmitter Mount</b>	Either meter mount or remote mount
<b>Sensor Cable Lengths</b>	<ul style="list-style-type: none"> <li>• <b>Standard:</b> 25'/7.6 m McCrometer supplied submersible cable with each remote mount unit.</li> <li>• <b>Optional:</b> Up to 500'/152.4 m, or 25'/7.6 m max for ProComm GO</li> <li>• <b>Custom Quick Connect:</b> Available in standard cable lengths: Feet: 25, 50, 75, 100, 125, 150, 175, 200, 500 Meters: 7.6, 15.25, 22.5, 30.5, 38.1, 45.75, 53.3, 61, 152.4 Custom quick connect cables at additional cost.</li> </ul>

### Performance and Operational Specifications

<b>Operating Temperature</b>	-10 to 60 °C (14 to 140 °F)
<b>Storage Temperature</b>	-15 to 60 °C (5 to 140 °F)
<b>IP Rating</b>	<ul style="list-style-type: none"> <li>• Quick Connect (NEMA 6P/IP68 with remote transmitter)</li> <li>• Compression gland seals (NEMA 6P/IP68 with remote transmitter)</li> </ul>
<b>Sensor Submersibility Depth</b>	<b>With standard strain relief cable:</b> 1.8 m (6 ft.) <b>With optional quick connect cable:</b> 9 m (30 ft.)
<b>Pressure Rating</b>	<ul style="list-style-type: none"> <li>• AWWA CL D, 150 PSI maximum working pressure</li> <li>• ANSI #150, 285 PSI maximum</li> <li>• ANSI #300, 500 PSI maximum</li> </ul>
<b>Velocity Range</b>	0.2 to 32 FPS

## Product Specifications

### Performance and Operational Specifications (cont.)

<b>Accuracy</b>	<ul style="list-style-type: none"> <li>Ultra Mag 3000: Battery powered: 1% of measured value <math>\pm 0.006</math> ft/s (<math>\pm 0.0018</math> m/s)</li> <li>Ultra Mag 5000: Standard: <math>\pm 0.5\%</math> of measured value <math>\pm 0.006</math> ft/s (<math>\pm 0.0018</math> m/s) Optional: <math>\pm 0.2\%</math> of measured value <math>\pm 0.006</math> ft/s (<math>\pm 0.0018</math> m/s)</li> </ul>
	<p><b>IMPORTANT NOTICE ON FLOW METER ACCURACY:</b> The Ultra Mag 3000 flow meter with remote display's cable and electronics are factory calibrated for accuracy as a single unit. Changing the cable length, even with the splice kit, changes the accuracy of the meter and invalidates the calibration certificate. The Ultra Mag 5000 flow meter does not have this restriction.</p> <p>Multiple point wet flow calibrations are conducted on every complete flow tube with its signal transmitter. If desired, the tests can be witnessed by the customer. The McCrometer test facilities are traceable to the National Institute of Standards &amp; Technology. Uncertainty relative to flow is <math>\pm 0.15\%</math>.</p>
<b>Repeatability</b>	$\pm 0.05\%$ or $\pm 0.0008$ ft/s ( $\pm 0.25$ mm/s), whichever is greater
<b>Head Loss</b>	None. No obstruction in line and no moving parts
<b>Conductivity</b>	5 $\mu$ s/cm
<b>Pipe Run Requirements</b>	<b>3000:</b> 1½" to 3" Flanged style meters      0D upstream / 0D downstream 4" - 24" Steel flanged meters          2D upstream / 1D downstream
	<b>5000:</b> 1½" to 3" Flanged style meters      0D upstream / 0D downstream 4" - 48" Steel flanged meters          1D upstream / 0D downstream

### Other Specifications

<b>Certifications and Approvals</b>	<p><b>Ultra Mag 3000</b></p> <p><b>Standard model:</b></p> <ul style="list-style-type: none"> <li>ISO 9001:2015 certified quality management system</li> <li>Certified by MET to UL 61010-1</li> <li>Certified to NSF / ANSI Standards*</li> </ul> <p><b>HL Model:</b></p> <ul style="list-style-type: none"> <li>ISO 9001:2015 certified quality management system</li> <li>Certified by MET to UL 61010-1 and MET C22.2 No. 61010-1-04               <ul style="list-style-type: none"> <li>Class I, Division 2, Groups A B C D, T4</li> <li>Class I, Zone 2, IIC T4</li> </ul> </li> <li>Certified to NSF / ANSI Standards*</li> </ul>
	<p><b>Ultra Mag 5000</b></p> <ul style="list-style-type: none"> <li>ISO 9001:2015 certified quality management system</li> <li>Certified to NSF / ANSI Standards*</li> </ul>
<b>System Options</b>	Stainless steel ID tag
<b>Meter Options and Accessories</b>	<ul style="list-style-type: none"> <li>Extended warranty</li> <li>Hastelloy® electrodes</li> <li>ANSI flanges</li> <li>Special lay lengths, including ISO standard lay lengths</li> <li>Additional sensor cable up to 475'</li> <li>Quick connect cable fittings</li> <li>Transmitter sun shield</li> <li>Smart Output™ (Sensus or Itron compatible)</li> <li>Battery or battery-solar powered transmitter (ProComm GO only)</li> </ul>
<b>Warranty</b>	<p><b>Meter:</b> 2 year warranty</p> <p><b>Liner:</b> Lifetime guarantee</p>

\* Certified by IAPMO R&T to NSF/ANSI 61 for material safety and NSF/ANSI 372 for low lead content.

## Flow Meter Dimensions

### 1½" to 3" Models

Pipe Size (Nominal)	Flow Ranges (0.2 to 32 FPS) Min-Max GPM	DIMENSIONS (Lay Lengths)								Est. Shipping Weight (lbs.)*	
		A		B	C		D		CL150 ANSI 150#	CL300 ANSI 300#	
		CL150 ANSI 150#	CL300 ANSI 300#		CL150 ANSI 150#	CL300 ANSI 300#	CL150 ANSI 150#	CL300 ANSI 300#			
1 ½"	1.29-200	11	14	4.5	5.0	6.1	6.5	7.25	93	not offered	
2"	1.29-200	11	14	4.5	6.0	6.5	6.5	7.25	93	70	
2 ½"	3.25-510	13.4	15.5	4.5	7.0	7.5	7.0	7.75	94	not offered	
3"	3.25-510	13.4	15.5	4.5	7.5	8.25	7.0	7.75	94	80	

\* For remote mount meters, add 4 lbs for ProComm Max transmitter.

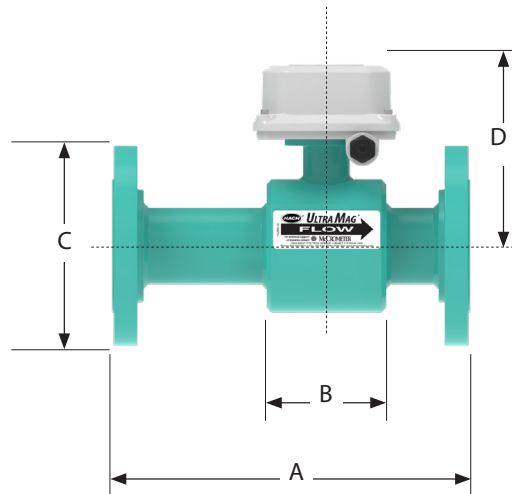

## Flow Meter Dimensions

### 4" to 12" Flanged End Body Style

Pipe Size (Nominal)	Flow Ranges (0.2 to 32 FPS) Min-Max GPM	DIMENSIONS (Lay Lengths)											Est. Shipping Weight (lbs.)*			
		A					B			C			AWWA		ANSI	
		AWWA 150# Class D	ANSI 150# CL150	ANSI 300# CL300	ISO ANSI 150# CL150	ISO ANSI 300# CL300	AWWA 150# Class D	ANSI 150# CL150	ANSI 300# CL300	AWWA 150# Class D	ANSI 150# CL150	ANSI 300# CL300	AWWA 150# Class D	ANSI 150# CL150	ANSI 300# CL300	
4"	6.97-1110	13.4	13.4	13.4	9.00	10.00	9.0	9.0	10.0	9.25	9.25	9.25	86	167	167	
6"	16.1-2560	14.6	14.6	14.6	11.00	12.50	11.0	11.0	12.5	10.25	10.25	10.25	98	186	186	
8"	29.2-4670	16.1	17.25	17.25	13.50	15.00	13.5	13.5	15.0	11.25	11.25	11.25	118	250	250	
10"	46.3-7400	18.5	18.5	18.5	16.00	17.50	16.0	16.0	17.5	12.5	12.5	12.5	168	290	290	
12"	67.3-10760	19.7	19.7	19.7	19.00	20.50	19.0	19.0	20.5	13.5	13.5	13.5	210	350	350	

\*Shipping weights are estimated and may change due to specific order packaging

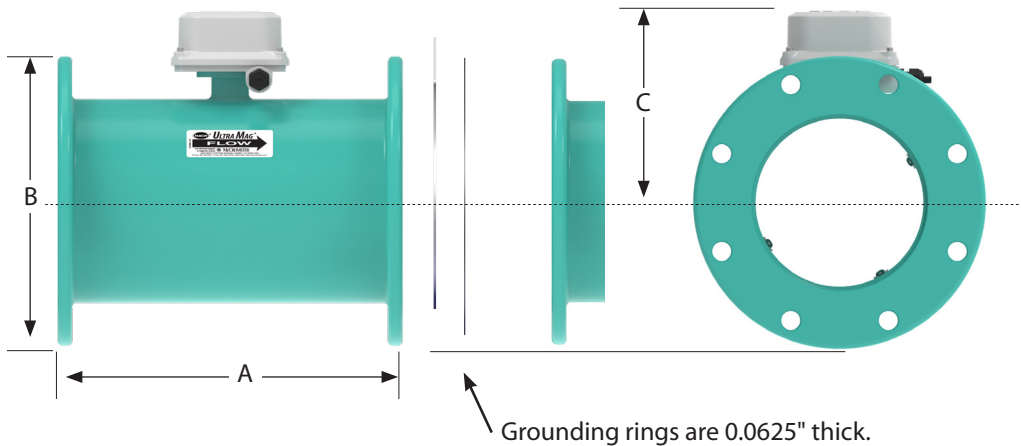

## Part Number Matrix

UM3		-								-		-		-		-	
Nominal Line Size																	
1.5"	0C																
2"	02																
2.5"	0D																
3"	03																
4"	04																
6"	06																
8"	08																
10"	10																
12"	12																
14"	14																
16"	16																
18"	18																
20"	20																
24"	24																
<b>Flange Connections</b>																	
AWWA Class D (150 psi Rating) (Standard)		1															
ANSI Class 150# (285 psi Rating)		2															
ANSI Class 300# (300 psi Rating)		3															
AWWA Class F (300 psi Rating)		4															
Wafer Style (2 & 3" Only)		N															
<b>Electrode Material Options</b>																	
S316 Stainless Steel (Standard)		S															
Hastelloy		H															
<b>Converter Mounting and Cable Connector Options</b>																	
Meter Mount Converter		M															
IP68 Strain Relief [ Remote Mount] (Standard)		R															
IP68 Quick Connect Potted Connector [ Remote Mount]		Q															
<b>Converter Power Options</b>																	
Battery Power (Standard)		B															
Solar Power, Battery Backup		S															
A/C Power, Battery Backup		E															
DC Power, Battery Backup		F															
<b>Converter Output Options</b>																	
No Outputs (Standard)																	
No Outputs, DC cable only		0															
Two Digital Out		1															
4-20mA Analog only		2															
4-20mA Analog + Two Dig Out		3															
<b>DC Power/ Analog Out Cable Options</b>																	
No DC Power or Outputs (Standard)																	
No Cable - Output Configured (Quick Conn)		0															
6 ft (Open Leads)		1															
25 ft (Open Leads)		2															
50 ft (Open Leads)		3															

## Part Number Matrix

UM3		-	-	-	-	-	-	-	-	-	-	-	-	-	-	-	-	-	-
<b>Pulse Cable Length Options</b>																			
<b>No Outputs (Standard)</b>																			
No Cable - Output Configured (Quick Conn)		0																	
6 ft (Open Leads)		1																	
25 ft (Open Leads)		2																	
50 ft (Open Leads)		3																	
<b>Output Cable Terminal Options</b>																			
Strain Relief		1																	
Quick Connect Cable Terminals		2																	
<b>Smart Output Protocol / SmartTrax Options</b>																			
<b>No AMI Outputs/SmartTrax Options</b>																			
Sensus Protocol (6ft cable, Nicor Connector hardwired only)		SEN																	
Itron 6 digit Protocol (6ft cable, Nicor Connector hardwired only)		IT6																	
Itron 9 digit [100W] Protocol (6ft cable, Nicor Connector hardwired only)		IT9																	
Neptune Protocol (6ft cable, Nicor Connector hardwired only)		NEP																	
2 ft SmartTrax Standalone Unit ExactRead Cable (Strain Relief Only)		S02																	
6 ft SmartTrax Standalone Unit ExactRead Cable (Strain Relief Only)		S06																	
25 ft SmartTrax Standalone Unit ExactRead Cable (Strain Relief Only)		S25																	
50 ft SmartTrax Standalone Unit ExactRead Cable (Strain Relief Only)		S50																	
<b>Non Standard Length Options</b>																			
<b>McCrometer Length (Standard)</b>																			
ISO Length (Only Available in ANSI)		ISO																	
Competitor Replacement Length		LS Select																	
Competitor Replacement Length		LP Length																	
Custom Specified Length (Nominal Length)		L(XX)																	
<b>Color Options</b>																			
<b>McCrometer Green (Standard)</b>																			
Sky Blue		SB																	
Dark Blue		DB																	
Lavender		LV																	
White		WH																	
<b>No Batteries, Battery Tray Options</b>																			
<b>Includes Batteries (Standard)</b>																			
No Batteries (Alkaline Tray)		NBA																	
No Batteries (Lithium Tray)		NBL																	
<b>Canadian Registration Certified</b>																			
<b>No CRN Needed</b>																			
CRN Certified (Sizes 4-12" ANSI Flanges Only)		CRN																	
<b>Hazardous Area Location</b>																			
<b>No Hazardous Location Needed</b>																			
Class 1, Division 2, Groups A-D, T5		HL																	

## Part Number Matrix

### 14+ " Flanged End Body Style

Pipe Size (nom.)	Flow Ranges (0.2 to 32 FPS) Min-Max GPM	DIMENSIONS												Est. Shipping Weight (lbs.)*			
		A						B	C				D**	AWWA		ANSI	
		AWWA		ANSI		ISO ANSI			AWWA		ANSI			AWWA		ANSI	
		150# Class D	300# Class F	150# CL150	300# CL300	150# CL150	300# CL300		150# Class D	300# Class F	150# CL150	300# CL300		150# Class D	300# Class F	150# CL150	300# CL300
14"	90.1-14410	21.70	22.75	22.75	22.75	21.00	23.00	10.38	21.00	23.00	21.00	23.00	13.56	290	370	370	550
16"	117-18670	23.60	25.25	25.25	25.25	23.50	25.50	12.38	23.50	25.50	23.50	25.50	14.31	352	443	443	639
18"	149-23820	23.60	25.25	25.25	25.25	25.00	28.00	12.38	25.00	28.00	25.00	28.00	15.31	400	492	492	801
20"	186-29600	25.60	28.25	28.25	28.25	27.50	30.50	14.38	27.50	30.50	27.50	30.50	16.25	465	603	603	973
24"	269-43040	30.70	35.75	35.75	35.75	32.00	36.00	18.88	32.00	36.00	32.00	36.00	18.25	658	864	864	1373
30"	418-66740	35.80	41.75	41.75	41.75	not offered		22.38	38.75	43.00	38.75	43.00	21.87	1067	1463	1463	2150
36"	607-97000	46.10	46.10	46.10	46.10			21.38	46.00	50.00	46.00	50.00	24.87	1529	2083	2083	3125
42"	831-132900	48.05	not offered	48.05	not offered			21.38	52.75	not offered	52.75	not offered	27.56	2113	2852	contact factory	
48"	1091-174440	50.00	not offered	50.00	not offered			21.38	59.50	not offered	59.50	not offered	30.56	2445	3139	contact factory	

\*Shipping weights are estimated and may change due to specific order packaging

\*\* DIM D represents the remote transmitter height in relation to the meter centerline.

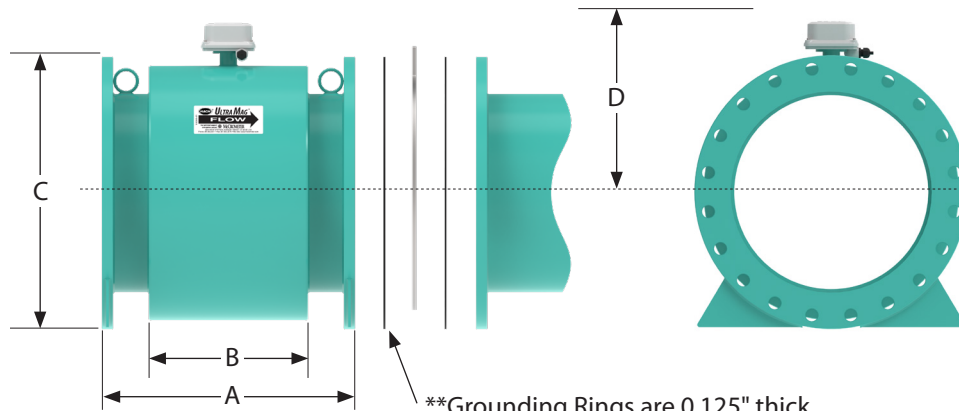

## Sensor Grounding and Electrical Interference

Grounding the meter body for safety according to national (NEC) or local electrical codes is recommended on ALL meter installations.

All Field Mag flow meter installations require minimum grounding with a 12-gauge ground wire to an earth ground.

### Flanged end meters

When installing into a PVC or plastic pipe system, grounding rings for flanged meters are recommended for all sizes. Flanges on the Field Mag sensor have a non-conductive coating and may not require grounding rings. For best performance, McCrometer provides grounding rings for all sizes.

For best performance, grounding the fluid column is recommended when the meter is installed in an electrically noisy environment, such as with VFD pumps or nearby electrical systems with insufficient grounding.

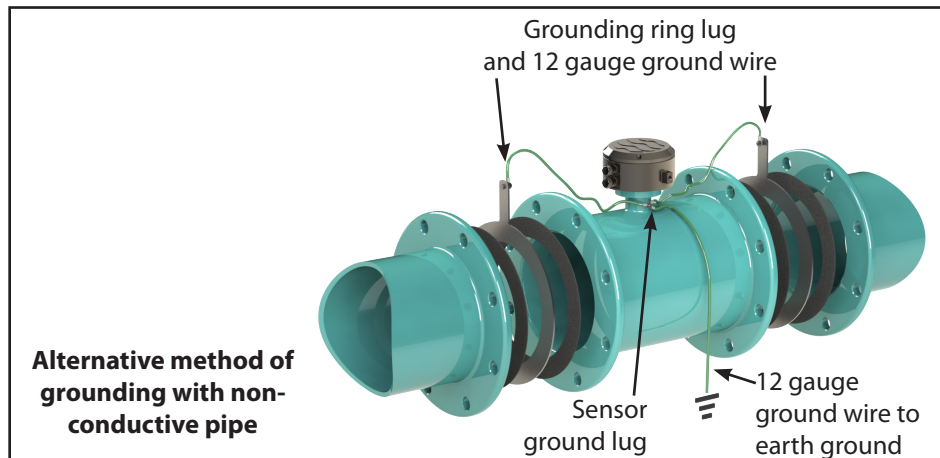
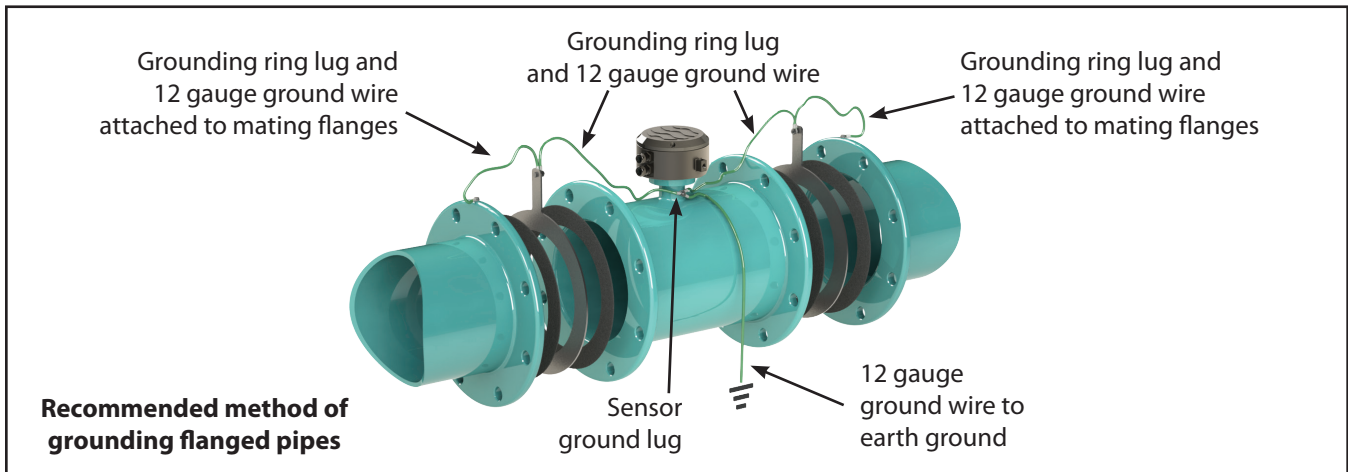

## Transmitter Specifications

Physical Specifications																																																	
<b>Electronic Housing</b>	Diecast aluminum, powder coated enclosure w/ tamper resistant seal, 6½" x 6½" x 43/8" tall																																																
<b>Transmitter Dimensions</b>	See "Dimensions" section for meter mount and remote mount transmitter dimensions.																																																
<b>Power</b>	<b>Battery:</b> Standard: three 3.6V lithium-thionyl chloride (Li-SOCl <sub>2</sub> ) D size batteries with two AA backup batteries <b>AC Power:</b> 100-240VAC/45-66Hz (4W) <b>DC Power:</b> Linear power supply 10-35VDC (4 W)																																																
<b>Electrical Connections</b>	<ul style="list-style-type: none"> <li>Optional shielded cable for 10-32VDC/4-20 mA output</li> <li>Optional shielded cable for pulse out</li> </ul>																																																
Performance and Operational Specifications																																																	
<b>Battery Life</b>	Five-year expected battery life, five-year battery warranty																																																
<b>Location</b>	Indoor or outdoor use																																																
<b>Altitude</b>	Operating: 2000 meters Storage: 12,000 meters																																																
<b>Operating Temperature</b>	-4° to 140° F (-20° to 60° C)																																																
<b>Storage Temperature</b>	-4° to 140° F (-20° to 60° C)																																																
<b>Relative Humidity</b>	0% to 100%																																																
<b>IP Rating</b>	IP67 Die cast aluminum transmitter																																																
<b>Outputs</b>	<b>Digital output:</b> Digital pulse (open collector) output for volumetric <ul style="list-style-type: none"> <li>- Two isolated digital pulse (open collector) outputs for volumetric</li> <li>- AMI output</li> </ul> <b>Analog output:</b> 4-20mA: Galvanically Isolated, 16 Bit resolution. All power configurations (including battery).  Note: 9-30 VDC loop power required (not supplied via transmitter)																																																
Display and Measurement																																																	
<b>Display</b>	<ul style="list-style-type: none"> <li>2-Line LCD display (no backlight)</li> <li>Non-volatile memory</li> <li>Anti-reverse totalizer (standard)</li> <li>Total (to 9 digits of precision)</li> <li>Flow rate and velocity (to 5 digits of precision)</li> <li>Two alarms: low battery and empty pipe (optional)</li> <li>Opening lid activates display</li> </ul>																																																
<b>Digits</b>	5 Rate, 9 Total																																																
<b>Units</b>	<table border="0"> <tr> <td>GPM</td><td>Gallons per minute</td> <td>IGM</td><td>Imperial gal per minute</td> <td>CFM</td><td>Cubic feet per minute</td> </tr> <tr> <td>MGD</td><td>Mega gal per day</td> <td>MI9</td><td>Miners inch (9G)</td> <td>B5M</td><td>Barrels per minute (55G)</td> </tr> <tr> <td>CFS</td><td>Cubic feet per second</td> <td>MI1</td><td>Miners inch (11.22G)</td> <td>B5H</td><td>Barrels per hour (55G)</td> </tr> <tr> <td>MLD</td><td>Megaliters per day</td> <td>APD</td><td>Acre feet per day</td> <td>B5D</td><td>Barrels per day (55G)</td> </tr> <tr> <td>LPS</td><td>Liters per second</td> <td>KLH</td><td>Kiloliters per hour</td> <td>B4M</td><td>Barrels per minute (42G)</td> </tr> <tr> <td>CMH</td><td>Cubic meters per hour</td> <td>LPH</td><td>Liters per hour</td> <td>B4H</td><td>Barrels per hour (42G)</td> </tr> <tr> <td>LPM</td><td>Liters per minute</td> <td>CMM</td><td>Cubic meters per minute</td> <td>B4D</td><td>Barrels per day (42G)</td> </tr> <tr> <td>GPH</td><td>Gallons per hour</td> <td>CFM</td><td>Cubic feet per minute</td> <td></td><td></td> </tr> </table>	GPM	Gallons per minute	IGM	Imperial gal per minute	CFM	Cubic feet per minute	MGD	Mega gal per day	MI9	Miners inch (9G)	B5M	Barrels per minute (55G)	CFS	Cubic feet per second	MI1	Miners inch (11.22G)	B5H	Barrels per hour (55G)	MLD	Megaliters per day	APD	Acre feet per day	B5D	Barrels per day (55G)	LPS	Liters per second	KLH	Kiloliters per hour	B4M	Barrels per minute (42G)	CMH	Cubic meters per hour	LPH	Liters per hour	B4H	Barrels per hour (42G)	LPM	Liters per minute	CMM	Cubic meters per minute	B4D	Barrels per day (42G)	GPH	Gallons per hour	CFM	Cubic feet per minute		
GPM	Gallons per minute	IGM	Imperial gal per minute	CFM	Cubic feet per minute																																												
MGD	Mega gal per day	MI9	Miners inch (9G)	B5M	Barrels per minute (55G)																																												
CFS	Cubic feet per second	MI1	Miners inch (11.22G)	B5H	Barrels per hour (55G)																																												
MLD	Megaliters per day	APD	Acre feet per day	B5D	Barrels per day (55G)																																												
LPS	Liters per second	KLH	Kiloliters per hour	B4M	Barrels per minute (42G)																																												
CMH	Cubic meters per hour	LPH	Liters per hour	B4H	Barrels per hour (42G)																																												
LPM	Liters per minute	CMM	Cubic meters per minute	B4D	Barrels per day (42G)																																												
GPH	Gallons per hour	CFM	Cubic feet per minute																																														

## Transmitter Specifications



### Display and Measurement (cont.)

<b>Totalizer Units</b>	GAL	Gallons	B42	Barrel (42G)	MH1	Miners Inch Hour (11.22G)
	CUF	Cubic Feet	B46	Barrel (46G)	MD1	Miners Inch Day (11.22G)
	AFT	Acre Feet	B55	Barrel (55G)	MH9	Miners Inch Hour (9G)
	CUM	Cubic Meters	IMG	Imperial Gallon	MD9	Miners Inch Day (9G)
	LIT	Liters	AIN	Acre Inch	KGL	Kilo Gallons
	MML	Megaliter	TON	Ton (Short)	MGL	Mega Gallons
	MTT	Metric Ton (KL)	MM1	Miners Inch Minute (11.22G)	IN3	Cubic Inch
	B31	Barrel (31G)	MM9	Miners Inch Minute (9G)		
<b>Data Logger</b>	Standard with all models, minimum of five years of data stored					

### Other Specifications

<b>Options and Accessories</b>	<ul style="list-style-type: none"> <li>Data Logger - included as standard with five years of data storage at default (12hr) interval. (Cable sold separately)</li> <li>AC, DC, and battery powered with battery backup powered available</li> </ul>
<b>Safety</b>	<ul style="list-style-type: none"> <li>IEC 61010-1, Pollution Degree II</li> <li>Overvoltage protection Category III</li> </ul>

### Certifications

<b>Standard Model</b>	<ul style="list-style-type: none"> <li>ISO 9001:2015 certified quality management system</li> <li>CE</li> <li>Certified by MET to UL 61010-1</li> </ul>	  
<b>HL Model</b>	<ul style="list-style-type: none"> <li>ISO 9001:2015 certified quality management system</li> <li>CE</li> <li>Certified by MET to UL 61010-1 and MET C22.2 No. 61010-1-04                             <ul style="list-style-type: none"> <li>Class I, Division 2, Groups A B C D, T4</li> <li>Class I, Zone 2, IIC T4</li> </ul> </li> </ul> <p><i>Note: ProComm GO with SmartTrax On Board is not available for hazardous locations.</i></p>	

### Transmitter Dimensions

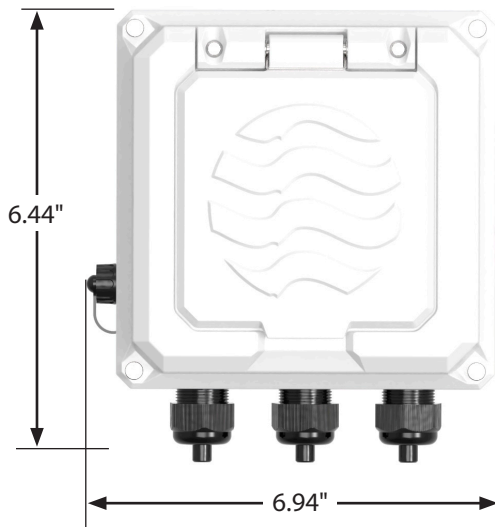

Meter mount converter

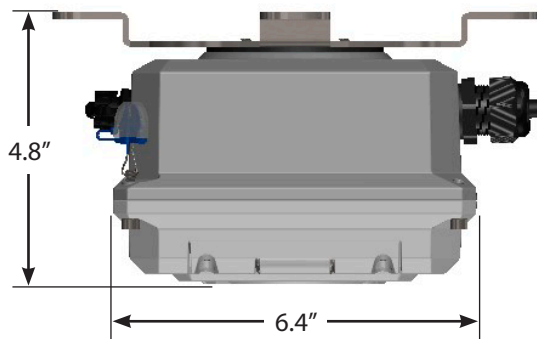
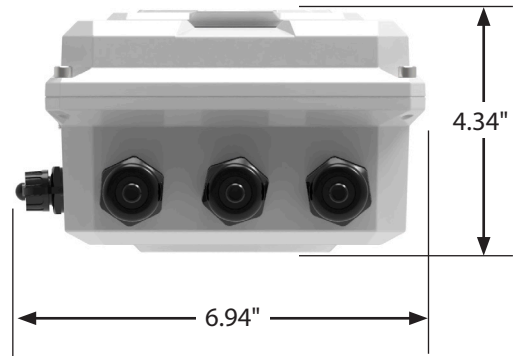

Remote mount converter

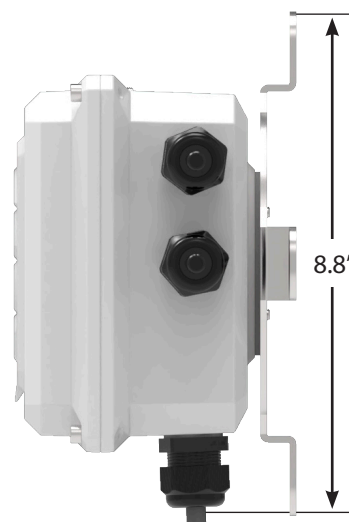
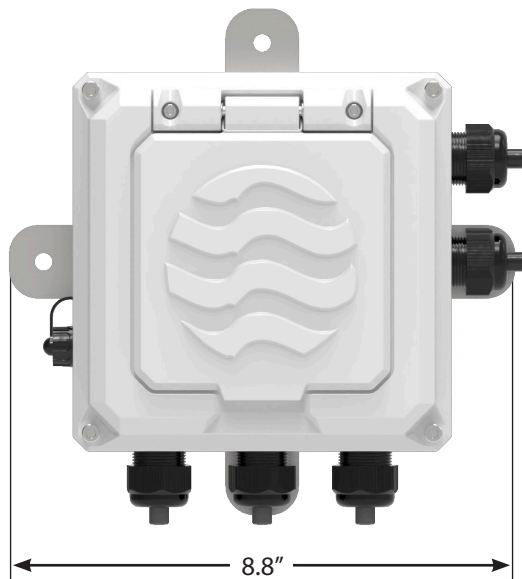

## Transmitter Cable Connections from Sensor

### Example Remote Mount Configuration

After installing the sensor, mount the transmitter and connect the cable to the meter's junction box and the transmitter's external connection. Figure 4 below shows an example of a remote mount installation with an optional Smart Output connection.

You will need to carefully plan the location where to install the remote transmitter. The location cannot be further from the flow meter than the length of the 25' cable. This must be planned in advance because the cable length cannot be altered as the cable is calibrated with the meter. Doing so will alter the calibration accuracy and void the warranty.

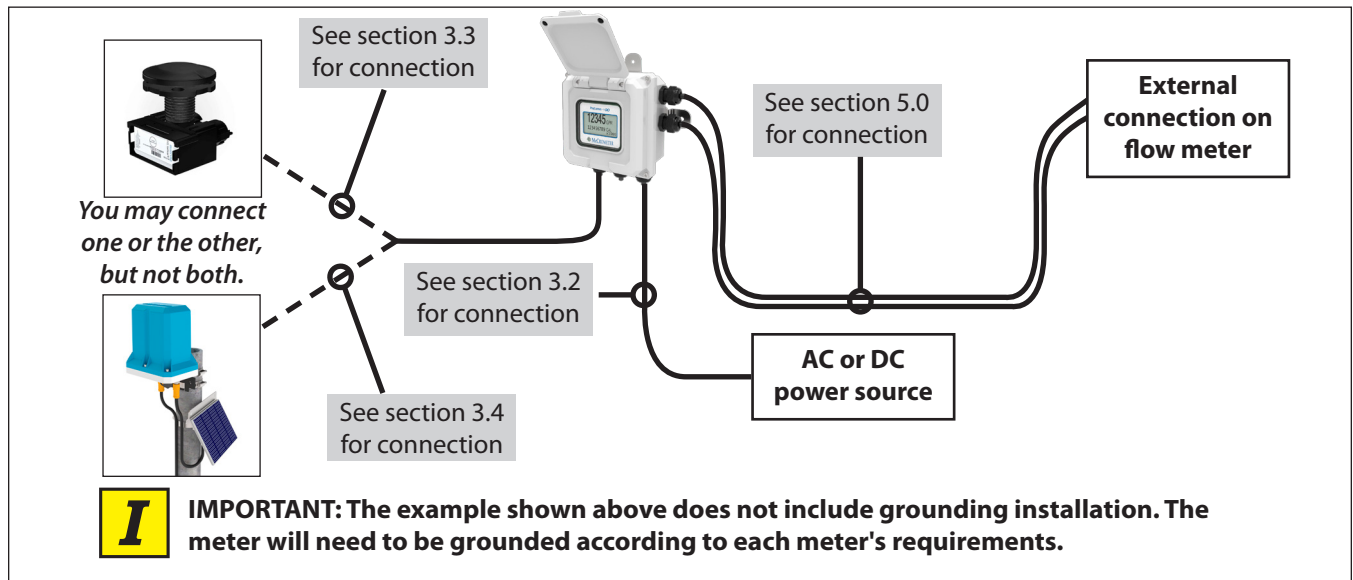

## Transmitter Cable Connections from Sensor

### Wiring Diagrams

#### TERMINAL BLOCK ASSIGNMENTS

##### Coils Harness

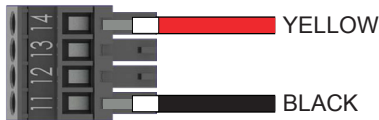

Terminal	Port	Wire Color
11	4	Black
14	4	Red

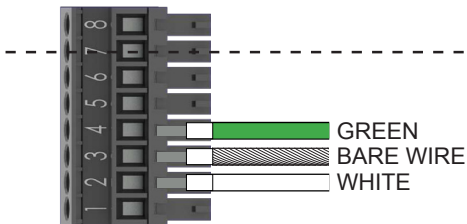

##### Electrodes Harness

Terminal	Port	Wire Color
2	5	White
3	5	Bare wire
4	5	Green

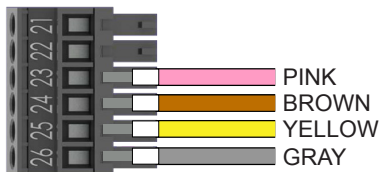

##### Pulse Output Harness

Terminal	Port	Wire Color
23	1	Pink
24	1	Brown
25	1	Yellow
26	1	Gray

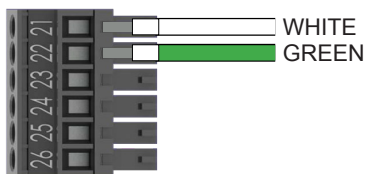

##### 4-20 mA Output Harness

Terminal	Port	Wire Color
21	1	White
22	1	Green



##### DC Power Harness

Terminal	Port	Wire Color
Positive	3	Red
Negative	3	Black

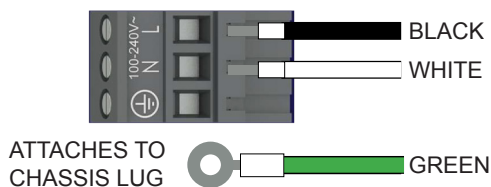

##### AC Power Harness

Terminal	Port	Wire Color
Load	3	Black
Neutral	3	White
Chassis lug	3	Green

To complete AC power connection, connect green grounding lug to chassis as shown on previous page.

## Battery Installation and Connection

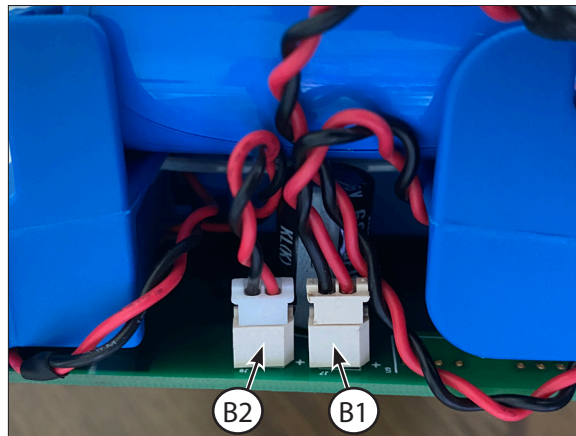
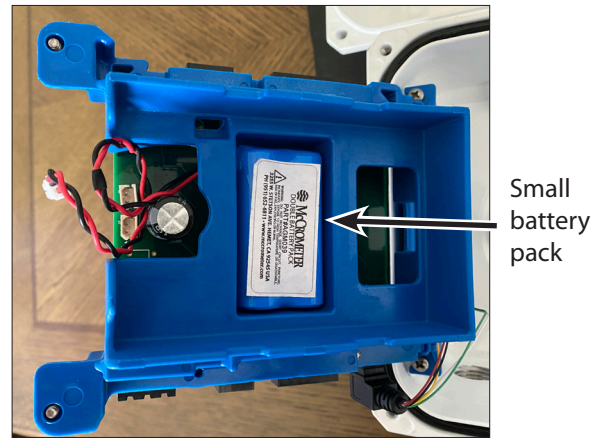
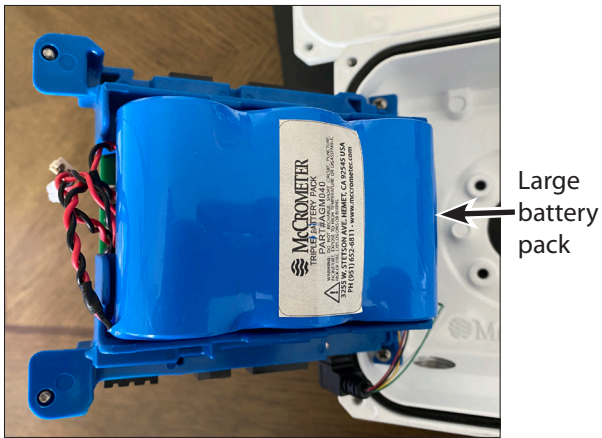
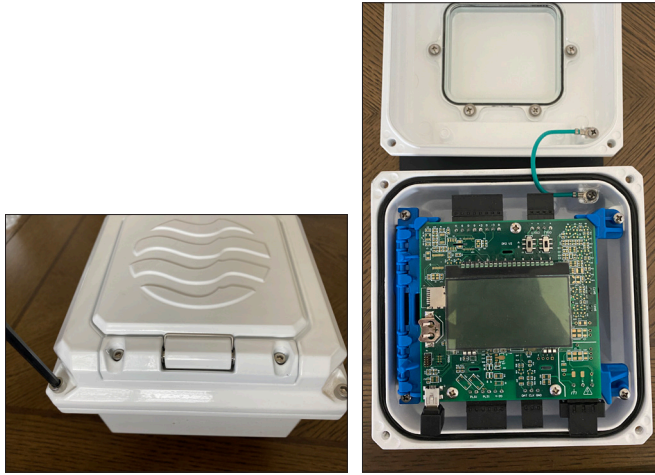



**McCrometer, Inc.**  
3255 West Stetson Avenue  
Hemet, CA 92545 USA  
Tel: 951-652-6811  
800-220-2279  
Fax: 951-652-3078  
customerservice@mccrometer.com  
www.mccrometer.com