

MODEL VC

DIN Slip-on, Flat Face Flanges

DESCRIPTION AND GENERAL PERFORMANCE SPECIFICATIONS

The V-Cone® flowmeter is a patented, differential pressure type flow measurement device. A cone is positioned in the center of the pipe to increase the velocity of the flowing fluid and create a differential pressure. This pressure difference can be measured and used to accurately interpret flowrate. Two taps are provided on every V-Cone to allow sensing of the high and low pressures. A typical V-Cone application can follow these general performance specifications:

- Accuracy: up to ±0.5% of rate
- Repeatability: ±0.1%
- Turndown: 10:1
- Standard Betas: 0.45 through 0.85
- Headloss: Percentage of differential pressure produced varies with beta ratio.
- Installation: Typically 0-3 diameters upstream and 0-1 diameters downstream.



The V-Cone is manufactured under a quality management system that is certified to ISO 9001:2015.

* Each V-Cone is sized for the intended application. Specific performance ratings must be obtained through the sizing process.

MODEL VC DIMENSIONS

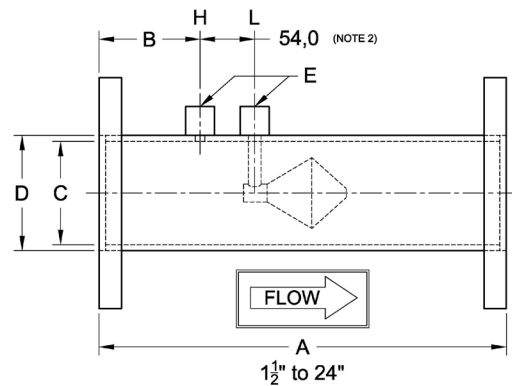
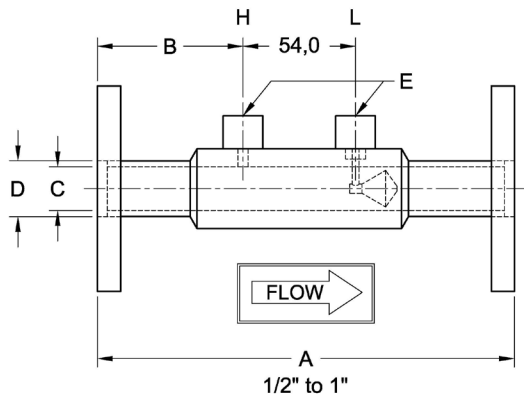

DIMENSION TABLE

Size	A (Note 1)	B	C-Stainless (Note 2)	C-Carbon (Note 2)	D	E (Note 2)
inch	mm	mm	mm	mm	mm	NPT
1/2	203	75	15,8	-	21,3	1/4
3/4	203	75	20,9	-	26,7	1/4
1	203	75	26,64	-	33,4	1/4
1 1/2	254	76	41,78	-	48,3	1/4
2	305	89	53,44	-	60,3	1/2
2 1/2	305	89	63,60	-	73,0	1/2
3	356	89	78,84	-	88,9	1/2
4	406	102	103,8	-	114	1/2
6	559	108	154,1	154,1	168	1/2
8	660	127	202,7	202,7	219	1/2
10	711	127	254,5	254,5	273	1/2
12	762	133	304,8	303,3	323	1/2
14	762	152	336,6	333,5	355	1/2
16	762	152	387,4	381,0	406	1/2
18	813	152	438,2	438,2	457	1/2
20	914	152	489,0	489,0	508	1/2
24	1219	254	590,6	590,6	609	1/2

1. Overall length (A) tolerance varies with line size: 1/2" to 1", ±1/16" (±2mm); 1 1/2" to 10", ±1/8" (±4mm); 12" to 24", ±3/16" (±6mm)
2. Typical values shown.
3. Wall pressure ports are required for vertical up flow applications.

MODEL NUMBER CONFIGURATION VC



SPECIFICATION SHEET

Type	Size	Materials‡		Pipe Schedule		End Connections		Fittings	
VC									
	0A ½"	Q	S304/L	D	Std	13	DIN 2576 PN 10 FF	N	NPT
	0B ¾"	A	S316/L	R	30			S	Socket
	01 1"	U	CS Pipe	E	40			F	Direct mount assembly
	0C 1½"		S304 Cone, Support, & Couplings		Q	60			
	02 2"	F	CS Pipe, Flanges, & Couplings,	F	80				
	0D 2½"		316/L Cone & Supports		J	100			
	03 3"	V	CS Pipe	K	120				
	04 4"		316/L Cone, Supports, & Couplings		L	140			
	06 6"	G	LTCS Pipe, Flanges, & Couplings,	G	160				
	08 8"		S316/L Cone & Supports		P	XS			
	10 10"			H	XXS				
	12 12"								
	14 14"								
	16 16"								
	18 18"								
	20 20"								
	24 24"								

Several types of fittings available.

‡Other materials can include:
 HASTELLOY C-276
 DUPLEX 2205
 CHROMEMOLY P22/P11
 MONEL K400/K500
 CARBON STEELS
 A350, A333, API5L, A106B
 S321H
 INCONEL 625

Example: VC03AE13N V-Cone 3 inch line size, S316L, Schedule 40, DIN 2576 PN 10 FF SO, ½" NPT fittings

STANDARD PIPE SCHEDULES

Stainless Steel		Carbon Steel	
Size	Std.	Size	Std.
½" to 10"	E	6" to 16"	E
12" and up	D	18" and up	D

Meters 6" and smaller utilize seamless pipe.
 Meters 8" and larger utilize welded pipe.

ABBREVIATIONS

ASME	American Society of Mechanical Engineers		
NPT	National pipe taper	CS	Carbon steel
SS	Stainless steel	FF	Flat Face
DIN	European Standard	SO	Slip On

Technical questions can be answered through a local representative or through our application engineers.

MANUFACTURING STANDARDS

McCrometer's welders and welding procedures are qualified in accordance with ASME Section IX. All meters are visually inspected for weld defects. Specific customer requirements can be complied with upon request.

The welding can be in accordance with:

- ASME Section VIII
- ASME B31.1
- ASME B31.3

Non-destructive testing can include:

- Hydrostatic Pressure Testing
- Penetrant Examination
- Positive Material Inspection
- Magnetic Particle Examination

REPRESENTED BY:

