

**Water Specialties Flow Meter
Specification Sheet**

**Water Specialties VFUR
150 psi Vertical Upflow Tee Tube Meter
Sizes 4" to 20"**
Configurable for Mechanical or Digital Register

Description..... 1
Features..... 1
Register Options..... 2
Description..... 3
Features..... 3
Register Options..... 3
Registers and Totalizers 5
Specifications for VFUR..... 7
Specifications for VFU1 VFUC VFDC 9
Dimensions of VFUR..... 11
Dimensions of VFU1 VFUC VFDC 12
Part Numbers, Digital Registers..... 13
FlowCom Digital Register Specification..... 16
FlowCom Part Number Matrix..... 18
FlowConnect Specifications..... 19
FlowConnect Dimensions..... 21

Description

MODEL VFUR VERTICAL UPFLOW TEE TUBE METERS are designed to meet AWWA specifications. The flanged end tee design permits use in a wide range of applications with up to 150 psi working pressure. The base and side outlets are 150 lb. AWWA class D flat face steel flanges. Fabricated steel meter tubes have straightening vanes and are protected internally and externally with 12-15 mils of NSF approved, fusion epoxy resin.

Features

PROPELLER is magnetically coupled with the drive mechanism through the sealed separator assembly. This completely eliminates water entering the meter assembly, as well as the need for any packing gland. The propeller is a conical shaped three bladed

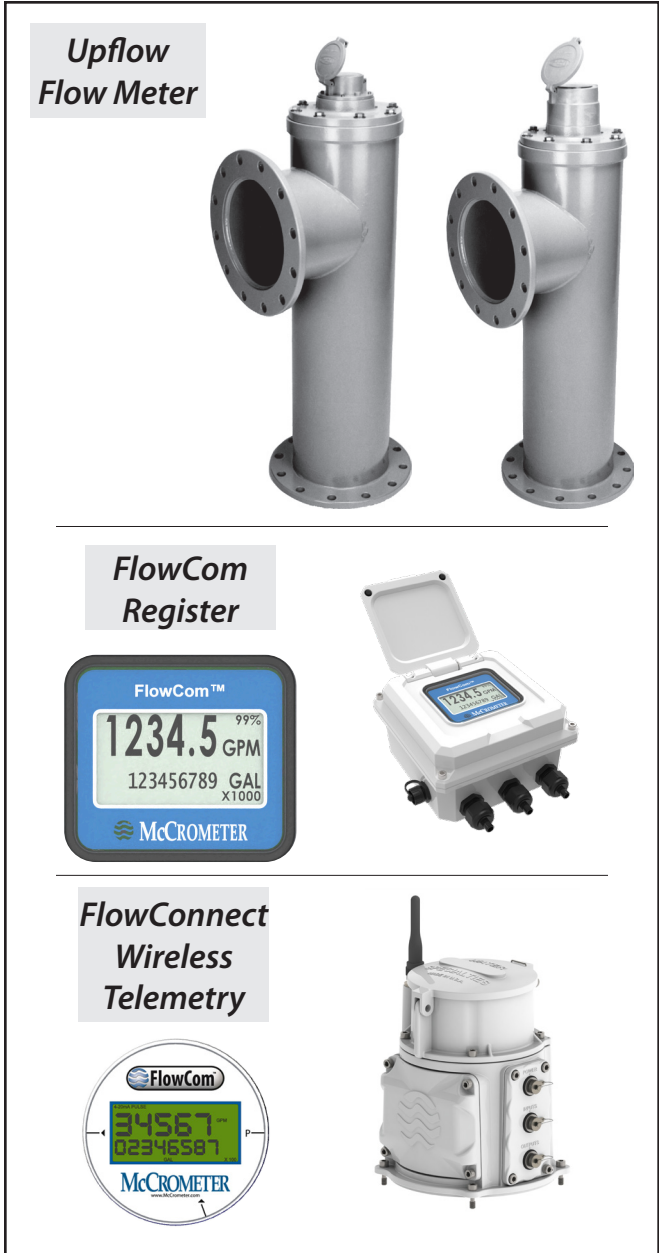

propeller, injection molded of thermoplastic material resistant to normal water corrosion and deformity due to high flow velocities.

BEARING in propeller is a water lubricated ceramic sleeve and spindle bearing system with a ceramic/ stainless steel spindle. Dual ceramic thrust bearings, standard on all meters, handle flows in both forward and reverse directions. The bearing design promotes extended periods of maintenance free propeller operation. Bearings within the sealed meter mechanism are shielded precision stainless steel

bearings and are factory lubricated for the life of the meter.

CHANGE GEARS may be easily exchanged in the field when changing the dial, or when recalibrating for different pipe sizes. It is not necessary to remove pressure from the line for these changes.

O-RING SEALS are used at the meter head and all points where seals are required, making the meter mechanism completely immune to any of the corrosive effects of atmospheric moisture or the liquids measured by the meter assembly.

Register Options

TOTALIZER is O-ring sealed and magnetically coupled with the driving mechanism, and features a six digit totalizer with a full 3" diameter, 100 division, center sweep dial that permits extremely accurate readings for timing purposes in determining flow rates. The totalizer dial can be furnished in gallons, cubic feet, acre feet or any standard liquid measuring units. The bonnet, with padlock hasp, can be positioned in four different directions for the easiest possible reading when the meters are mounted in unusual positions.

INDICATOR-TOTALIZER is mechanically driven by the meter mechanism and features a full 4" diameter, 250 degree sweep dial with a six digit, straight reading type totalizer and sweep test hand. The indicator drive mechanism is temperature compensated so the indicator will be accurate at all points on the dial when operated between 32° and 140° F. The indicator dial can be furnished in GPM, CFS, MGD or any standard liquid measuring units with choice of standard totalizer measuring units. The bonnet, with padlock hasp, is O-ring sealed to the meter head.

FLOWCOM DIGITAL REGISTER displays a flowmeter's flowrate and volumetric total. Available are four optional outputs: 4-20mA loop, open collector, optically isolated, and contact closure. Unique units of measurement for rate, total, 4-20mA, and pulse outputs. The FlowCom can be fitted to any new or existing McCrometer propeller flowmeter.

**Water Specialties Models VFU1 VFUC VFDC
150 psi Vertical Upflow and Downflow Tee
Tube Top Plate Assemblies
Sizes 4" to 20"
Configurable for Mechanical or Digital Register**

Description

MODELS VFU1, VFUC, AND VFDC meet AWWA specifications and are designed for mounting in tees with up to 150 PSI working pressure. The bolt-on design permits use in a wide range of applications with up to 150 psi working pressure. The mounting flange conforms to ANSI class 125 drilling. It is necessary, upon ordering, to furnish the I.D. dimension of the pipe the meter is to be mounted on for calibration purposes.

Features

PROPELLER is magnetically coupled with electronic sensor through the sealed separator assembly. This completely eliminates water entering the meter assembly, and eliminates all moving parts except for the propeller. The propeller is a conical shaped three bladed propeller, injection molded of thermoplastic material resistant to normal water corrosion and deformity due to high flow velocities.

BEARING in propeller is a water lubricated ceramic sleeve bearing that rides on a ceramic coated stainless steel spindle. Dual ceramic thrust bearings, standard on all meters, handle flows in both forward and reverse directions. The bearing design promotes extended periods of maintenance free propeller operation. Bearings within the sealed meter mechanism are shielded precision stainless steel bearings and are factory lubricated for the life of the meter.

Register Options

TOTALIZER is O-ring sealed and magnetically coupled with the driving mechanism, and features a six digit totalizer with a full 3" diameter, 100 division, center sweep dial that permits extremely accurate readings for timing purposes in determining flow rates. The totalizer dial can be furnished in gallons, cubic feet, acre feet or any standard liquid measuring units. The bonnet, with padlock hasp, can be positioned in four

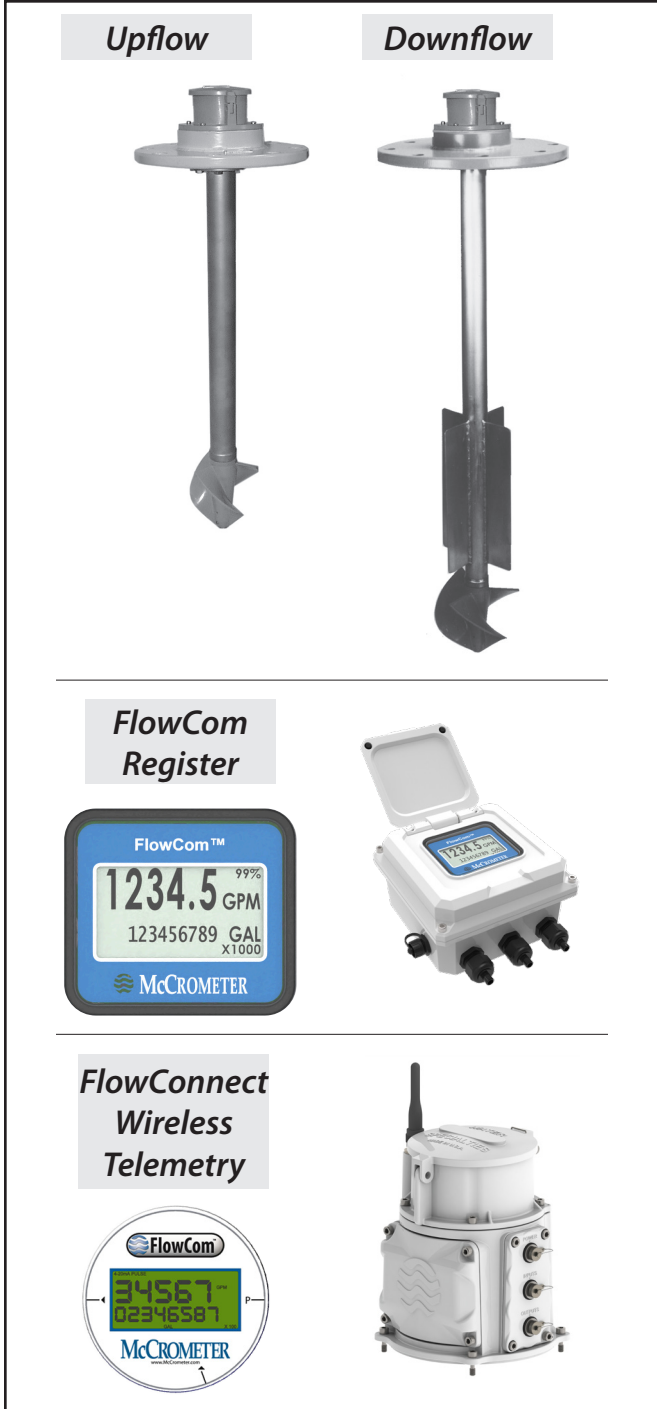

different directions for the easiest possible reading when the meters are mounted in unusual positions.

INDICATOR-TOTALIZER is mechanically driven by the meter mechanism and features a full 4" diameter, 250 degree sweep dial with a six digit, straight reading type totalizer and sweep test hand. The indicator drive mechanism is temperature compensated so the

indicator will be accurate at all points on the dial when operated between 32° and 140° F. The indicator dial can be furnished in GPM, CFS, MGD or any standard liquid measuring units with choice of standard totalizer measuring units. The bonnet, with padlock hasp, is O-ring sealed to the meter head.

FLOWCOM DIGITAL REGISTER displays a flowmeter's flowrate and volumetric total. Available are four optional outputs: 4-20mA loop, open collector, optically isolated, and contact closure. Unique units of measurement for rate, total, 4-20mA, and pulse outputs. The FlowCom can be fitted to any new or existing McCrometer propeller flowmeter.

Registers and Totalizers

Mechanical Register and Indicator-Totalizer

The instantaneous flow rate indicator is standard and available in gallons per minute, cubic feet per second, liters per second and other units.

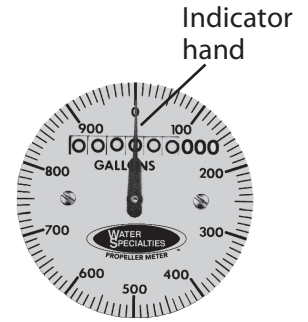
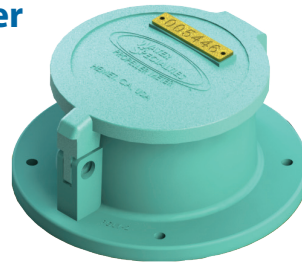

Standard register

The register housing protects both the register and cable drive system from moisture while allowing clear reading of the flow rate indicator and totalizer.

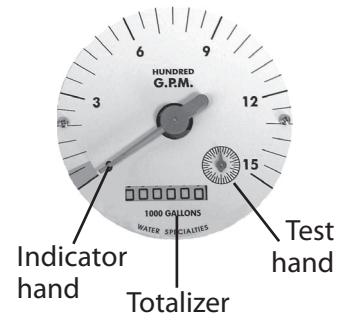

Indicator-totalizer

Digital Totalizer

The optional FlowCom digital register displays a flowmeter's flowrate and volumetric total. Available are four optional outputs: 4-20mA loop, open collector, optically isolated, and contact closure. Unique units of measurement for rate, total, 4-20mA, and pulse outputs. The FlowCom can be fitted to any new or existing McCrometer propeller flowmeter.



FlowCom register

Wireless Telemetry

The optional FlowConnect is designed specifically for wireless telemetry via either satellite or cellular data service. Manual meter reading is never required. It uses either the mechanical register or the digital register (both shown above).

You can determine how often readings are made and transmitted to the cloud database, which you can view on a PC or on a cell phone. The viewing utility provides data tools that can analyze flow rate, consumption, and possible anomalies in an irrigation system.



FlowConnect

INSTALLATION

Flanged end meters: A tube is inserted into a section of open pipe and each flanged end is joined to the existing pipe using the provided gaskets and bolts.

Plain, grooved, or threaded end meters: A tube is inserted into a section of open pipe and each end is joined to the existing pipe as appropriate to its type.

The meter can be installed horizontally, vertically, or inclined on suction or discharge lines. The meter must have a full flow of liquid for proper accuracy. Complete installation, removal, and reinstallation instructions can be found in the meter's Installation, Operation, and Maintenance Manual.

PIPE RUN REQUIREMENTS

Fully opened gate valves, fittings or other obstructions that tend to set up flow disturbances should be a minimum of ten pipe diameters upstream and two pipe diameters downstream from the meter. Installations with less than ten pipe diameters of straight pipe require straightening vanes. Meters with straightening vanes require at least five pipe diameters upstream and two pipe diameters downstream of the meter.

Configuration	A	B
Without straightening vanes	10	1
With straightening vanes	5	1

Dimension C varies depending on meter size.	
Meters 2 - 20"	8"
Meters 24" - 72"	11 1/2"

STRAIGHTENING VANES

Special attention should be given to systems using two elbows "out of plane" or devices such as a centrifugal sand separator. These cause swirling flow in the line that affect propeller meters. Well developed swirls can travel up to 100 diameters downstream if unobstructed. Since most installations have less than 100 diameters to work with, straightening vanes become necessary to alleviate the problem.

Straightening vanes will break up most swirls and ensure more accurate measurement. McCrometer actively encourages installing vanes just ahead of the meter. Straightening vanes are available in weld-in and bolt-in.

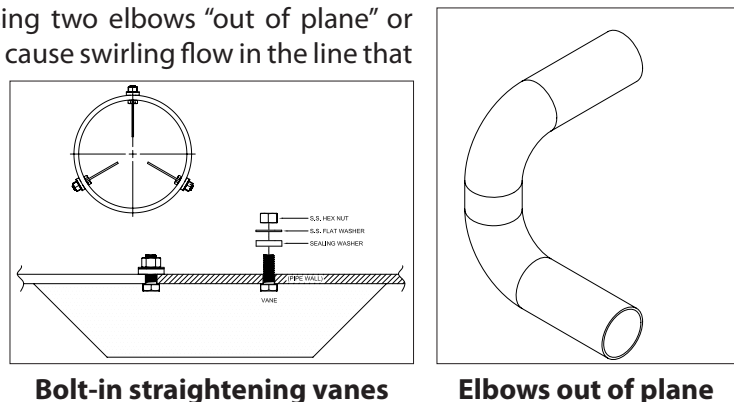

Bolt-in straightening vanes

Elbows out of plane

Specifications for VFUR

Performance

Accuracy	Plus or minus 2% of actual flow within the range specified for each meter size
Pressure Range	Up to 150 PSI maximum working pressure
Temperature Range	140° F Maximum. Consult factory for special construction for higher temperatures.
Flow Ranges	See Min-Max-Int Flow Ranges column in the table of meter specifications on page 11. <ul style="list-style-type: none"> • Size and construction are rated for continuous operation. • Min and max flow ranges will vary according to meter size and construction. • Min flow will be higher when auxiliary equipment is added. • Intermittent flow is rated for 10%-15% of the total time the meter is operating. • Consult factory for high velocity construction when intermittent flows are higher than shown in the table of meter specifications on page 11 and/or when longer operating periods are required.

Materials

Materials used in construction are chosen to minimize the corrosive effects of the liquids measured by the meter assembly.

Magnets	Anticorrosive aluminized barrier coated magnets; Everlube 6155
Interior Bearings	Shielded stainless steel
Propeller Bearing	Ceramic sleeve type
Propeller Spindle	Ceramic coated stainless steel
Propeller	Injection molded thermoplastic
Drop-Pipe	Stainless steel
Separator	Stainless steel
Shafts and Bolts	Stainless steel
Meter Head	Cast iron, NSF approved, fusion epoxy coated
Meter Tube	Fabricated steel with 12-15 mils of NSF approved, fusion epoxy resin

Optional Equipment

- A meter mounted forward and reverse totalizer
 - Totalizer extensions
 - Remote mounting kit with up to 50 feet of cable
 - A wide range of controls and instruments for indicating, totalizing, and recording flow data for each meter
- Special constructions and materials are available upon request.

FCC CERTIFICATION: The digital indicator-totalizer has been tested and found to comply with the limits for Class A digital device pursuant to Part 15 of the FCC Rules.

Ordering Info

Meters must be specified by the customer and includes:

- Meter size
- Model number
- Serial number of the meter it is replacing
- Minimum & maximum flow ranges
- Temperature of meter environment
- Indicator scale & units
- Totalizer dial units
- Type of materials and construction
- Optional equipment desired

Specifications for VFU1 VFUC VFDC

Performance

Accuracy	Plus or minus 2% of actual flow within the range specified for each meter size.
Pressure Range	Up to 150 PSI maximum working pressure.
Temperature Range	140° F Maximum. Consult factory for special construction for higher temperatures.
Flow Ranges	See Min-Max-Int Flow Ranges column in the table of meter specifications on page 12. <ul style="list-style-type: none"> • Size and construction are rated for continuous operation. • Min and max flow ranges will vary according to meter size and construction. • Min flow will be higher when auxiliary equipment is added. • Intermittent flow is rated for 10%-15% of the total time the meter is operating. • Consult factory for high velocity construction when intermittent flows are higher than shown in the table of meter specifications on page 12 and/or when longer operating periods are required.

Materials

Materials used in construction are chosen to minimize the corrosive effects of the liquids measured by the meter assembly.

Magnets	Anticorrosive aluminized barrier coated magnets; Everlube 6155
Interior Bearings	Shielded stainless steel
Propeller Bearing	Ceramic sleeve type
Propeller Spindle	Ceramic coated stainless steel
Propeller	Injection molded thermoplastic
Drop-Pipe	Stainless steel
Separator	Stainless steel
Shafts and Bolts	Stainless steel
Meter Head	Cast iron or fabricated steel, fusion epoxy coated.

Optional Equipment

- A meter mounted forward and reverse totalizer
 - Totalizer extensions
 - Remote mounting kit with up to 50 feet of cable
 - A wide range of controls and instruments for indicating, totalizing, and recording flow data for each meter
- Special constructions and materials are available upon request.

FCC CERTIFICATION: The digital indicator-totalizer has been tested and found to comply with the limits for Class A digital device pursuant to Part 15 of the FCC Rules.

Ordering Info

Meters must be specified by the customer and includes:

- Meter size
- Model number
- Serial number of the meter it is replacing
- Minimum & maximum flow ranges
- Temperature of meter environment
- Indicator scale & units
- Totalizer dial units
- Type of materials and construction
- Optional equipment desired

Dimensions of VFUR

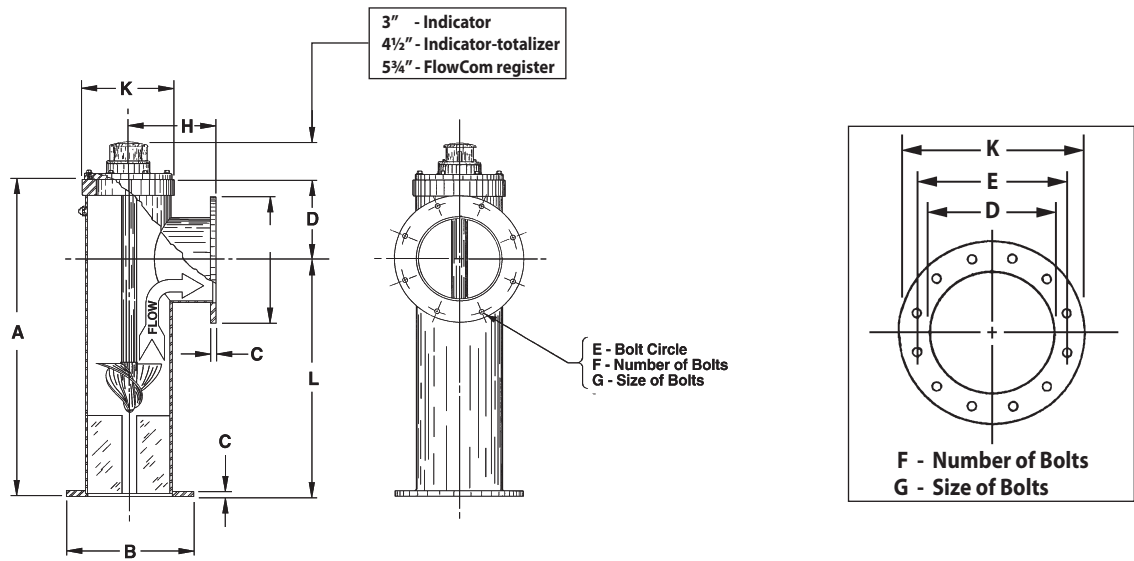

Meter & Pipe size (inches)	Flow Ranges, GPM Min - Max - Int	Standard Dial Face (GPM/Gal.)	Dimensions										Est. Shipping Weight (lbs.)
			A	B	C	D	E	F	G	H	K	L	
4	55 - 500 - 700	500/100	18	9	5/8	4 1/2	7 1/2	8	5/8	5	6	13 1/2	180
6	130 - 1200 - 1500	1200/1000	40	11	1 1/16	10	9 1/2	8	3/4	9	11	30	190
8	170 - 1500 - 2000	1500/1000	40	13 1/2	1 1/16	10	11 3/4	8	3/4	10	11	30	240
10	200 - 2000 - 3000	2000/1000	40	16	1 1/16	10	14 1/4	12	7/8	11	11	30	330
12	220 - 3000 - 3500	3000/1000	40	19	1 3/16	10	17	12	7/8	12	11	30	440
14	320 - 4000 - 4500	4000/1000	46	21	1 5/16	10	18 3/4	12	1	14	11	36	520
16	420 - 5000 - 6000	5000/1000	54	23 1/2	1	11 1/2	21 1/4	16	1	15	11	42 1/2	620
18	720 - 6000 - 7500	6000/1000	60	25	1 1/16	12	22 3/4	16	1 1/8	18	11	48	720
20	870 - 8000 - 9000	8000/10000	66	27 1/2	1 1/8	14	25	20	1 1/8	20	11	52	820

Standard construction will be supplied for all main line meters unless special flow range, materials, or construction are required.

Dimensions of VFU1 VFUC VFDC

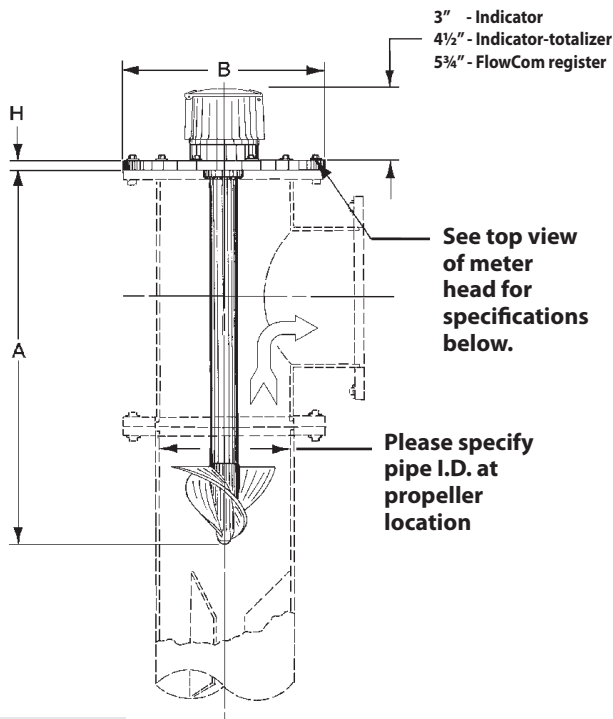

Upflow

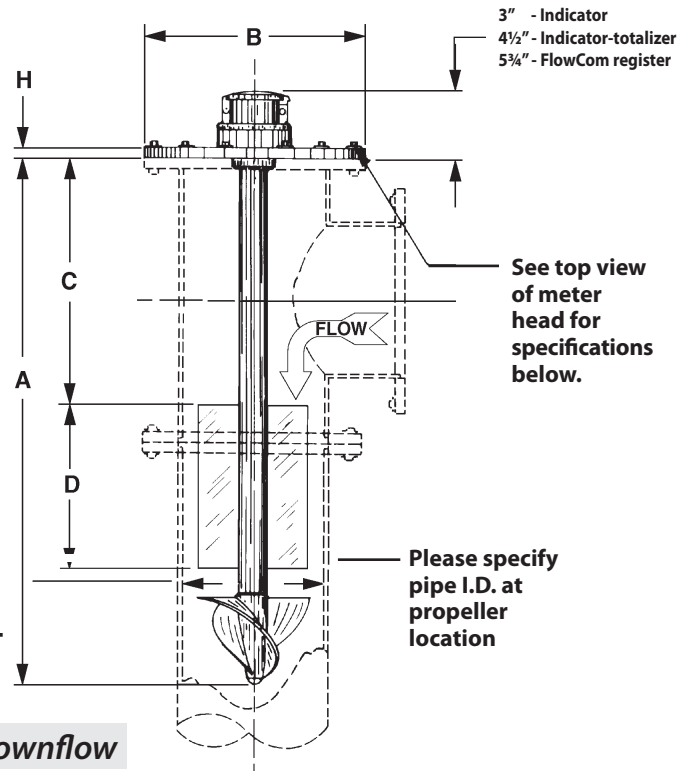

Downflow

Meter & Pipe size (inches)	Flow Ranges, GPM Min - Max - Int	Standard Dial Face (GPM/Gal.)*	Dimensions						Est. Shipping Weight (lbs.)
			A	B	E	F	G	H	
4	55 - 500 - 700	500/100	28	9	7 1/2	8	5/8	5/8	60
6	130 - 1200 - 1500	1200/1000	28	11	9 1/2	8	3/4	11/16	75
8	170 - 1500 - 2000	1500/1000	28	13 1/2	11 3/4	8	3/4	11/16	90
10	200 - 2000 - 3000	2000/1000	28	16	14 1/4	12	7/8	11/16	110
12	220 - 3000 - 3500	3000/1000	28	19	17	12	7/8	13/16	140
14	320 - 4000 - 4500	4000/1000	30	21	18 3/4	12	1	15/16	175
16	420 - 5000 - 6000	5000/1000	34	23 1/2	21 1/4	16	1	1	200
18	720 - 6000 - 7500	6000/1000	36 1/2	25	22 3/4	16	11/8	11/16	230
20	870 - 8000 - 9000	8000/10000	40 1/2	27 1/2	25	20	11/8	11/8	260

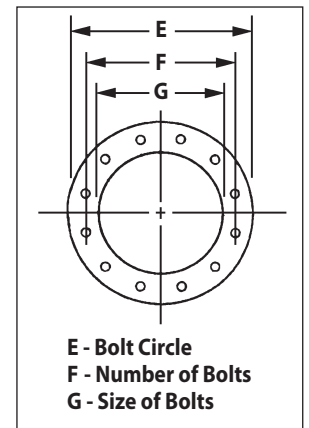

Meter & Pipe size (inches)	Flow Ranges, GPM Min - Max - Int	Standard Dial Face (GPM/Gal.)*	Dimensions								Est. Shipping Weight (lbs.)
			A	B	C	D	E	F	G	H	
4	55 - 500 - 700	500/100	34	9	13 3/8	12	7 1/2	8	5/8	5/8	70
6	130 - 1200 - 1500	1200/1000	36 1/2	11	16	12	9 1/2	8	3/4	11/16	90
8	170 - 1500 - 2000	1500/1000	40 1/2	13 1/2	20	12	11 3/4	8	3/4	11/16	120
10	200 - 2000 - 3000	2000/1000	44	16	26 1/2	12	14 1/4	12	7/8	11/16	135
12	220 - 3000 - 3500	3000/1000	48	19	27 1/2	12	17	12	7/8	13/16	215
14	320 - 4000 - 4500	4000/1000	54	21	31 1/2	14	18 3/4	12	1	15/16	250
16	420 - 5000 - 6000	5000/1000	60	23 1/2	35 1/2	16	21 1/4	16	1	1	280
18	720 - 6000 - 7500	6000/1000	66	25	39 1/2	18	22 1/4	16	11/8	1 1/16	310
20	870 - 8000 - 9000	8000/10000	72	27 1/2	43 1/2	20	25	20	11/8	1 1/8	390

Part Numbers, Digital Registers

VF													
CONNECTION OPTIONS:													
Up Flow with WS Tee Tube- VF29/VF30/VF30D		UR											
Up Flow for WS Tee Tube (Top Plate Only)- VFT1/VF11/VF11D		U1											
Up Flow for Customer Tee Tube (Top Plate Only)- VF28D		UC											
Down Flow for Customer Tee Tube (Top Plate Only)- VF32D		DC											
METER SIZE													
4" Vertical Flow Meter		04											
6" Vertical Flow Meter		06											
8" Vertical Flow Meter		08											
10" Vertical Flow Meter		10											
12" Vertical Flow Meter		12											
14" Vertical Flow Meter		14											
16" Vertical Flow Meter		16											
18" Vertical Flow Meter		18											
20" Vertical Flow Meter		20											
Body/ Drop pipe Options													
Standard Body/ Drop Pipe		A											
Non Standard Tube		X											
Prop Options													
Standard		1											
High Velocity		2											
Standard Velocity Slip on Separator		3											
High Velocity Slip on Separator		4											
Register Options													
Flowcom (FC200)		F											
Flow Connect (FC Smart Part on 2nd Line)		T											
Output Options													
No Outputs													
Open Collector Pulse		1											
4-20mA Analog Only		2											
4-20mA Analog + Open Collector Pulse		3											
Output Cable Options													
No Output Cables													
6 ft		C1											
15 ft		C2											
25 ft		C3											
50 ft		C4											
75 ft		C5											
100 ft		C6											
150 ft		C8											

continued on next page

Part Numbers, Digital Registers (cont.)

VF	-	-	-	-
Smart Output Protocol / Telemetry Options				
No AMI Outputs/Telemetry Options				
Sensus Protocol (6ft cable, Nicor Connector hardwired only)	SEN			
Itron 6 digit Protocol (6ft cable, Nicor Connector hardwired only)	IT6			
Itron 9 digit [100W] Protocol (6ft cable, Nicor Connector hardwired only)	IT9			
Neptune Protocol (6ft cable, Nicor Connector hardwired only)	NEP			
2 ft SmartTrax Standalone Unit ExactRead Cable	S02			
6 ft SmartTrax Standalone Unit ExactRead Cable	S06			
25 ft SmartTrax Standalone Unit ExactRead Cable	S25			
50 ft SmartTrax Standalone Unit ExactRead Cable	S50			
Register Remote and Extension Options				
Meter Mount (Standard)				
6 ft Cable Remote Mount (Flowcom only)	R06			
25 ft Cable Remote Mount (Flowcom only)	R25			
50 ft Cable Remote Mount (Flowcom only)	R50			
6" Long Extension	006			
1" Increments for Extensions Lengths	XXX			
240" Maximum extension length	240			
SPECIAL OPTIONS				
High Temp Prop and Seals	H			
No Batteries, Battery Tray Options				
Includes Batteries (Standard)				
No Batteries (Alkaline Tray)	NBA			
No Batteries (Lithium Tray)	NBL			

Part Numbers, Mechanical Registers (cont.)

VF							
CONNECTION OPTIONS:							
Up Flow with WS Tee Tube- VF29/VF30/VF30D	UR						
Up Flow for WS Tee Tube (Top Plate Only)- VFT1/VFI1/VFI1D	U1						
Up Flow for Customer Tee Tube (Top Plate Only)- VF28D	UC						
Down Flow for Customer Tee Tube (Top Plate Only)- VF32D	DC						
METER SIZE							
4" Vertical Flow Meter	04						
6" Vertical Flow Meter	06						
8" Vertical Flow Meter	08						
10" Vertical Flow Meter	10						
12" Vertical Flow Meter	12						
14" Vertical Flow Meter	14						
16" Vertical Flow Meter	16						
18" Vertical Flow Meter	18						
20" Vertical Flow Meter	20						
Body/ Drop pipe Options							
Standard Body/ Drop Pipe	A						
Non Standard Tube	X						
Prop Options							
Standard	1						
High Velocity	2						
Standard Velocity Slip on Seperator	3						
High Velocity Slip on Seperator	4						
Register Options							
Totalizer	1						
Indicator/Totalizer	2						
Output Options							
No Outputs							
4-20 Analog Only (TR15/TR16)	A						
Dry Contact Pulse & 4-20 Analog (TR04/TR12 + TR15/TR16)	B						
Dry Contact Pulse (TR04/TR12)	C						
Extension Options							
Meter Mount (Standard)							
6" Long Extension	006						
1" Increments for Extensions Lengths	XXX						
144" Maximum extension length	144						
SPECIAL OPTIONS							
No Special Options							
High Temp Prop and Seals	H						

FlowCom Digital Register Specification

Physical Specifications

Electronic Housing	Diecast aluminum, powder coated enclosure w/ tamper resistant seal, 6½" x 6½" x 43/8" tall
Digital register Dimensions	See "Dimensions" section for meter mount and remote mount digital register dimensions.
Power	Battery: Standard: three 3.6V lithium-thionyl chloride (Li-SOCI2) D size batteries
Electrical Connections	Optional shielded cable for pulse out

Performance and Operational Specifications

Battery Life	Five-year expected battery life, five-year battery warranty
Location	Indoor or outdoor use
Altitude	Operating: 2000 meters Storage: 12,000 meters
Operating Temperature	-4° to 140° F (-20° to 60° C)
Storage Temperature	-4° to 140° F (-20° to 60° C)
Relative Humidity	0% to 100%
IP Rating	IP67 Die cast aluminum digital register
Outputs	<p>Digital output: Digital pulse (open collector) output for volumetric</p> <ul style="list-style-type: none"> - Two isolated digital pulse (open collector) outputs for volumetric - AMI output <p>Analog output: 4-20mA: Galvanically Isolated, 16 Bit resolution. All power configurations (including battery).</p> <p>Note: 9-30 VDC loop power required (not supplied via digital register)</p>

Display and Measurement

Display	<ul style="list-style-type: none"> • 2-Line LCD display (no backlight) • Non-volatile memory • Anti-reverse totalizer (standard) • Total (to 9 digits of precision) 	<ul style="list-style-type: none"> • Flow rate and velocity (to 5 digits of precision) • Two alarms: low battery and empty pipe (optional) • Opening lid activates display
Digits	5 Rate, 9 Total	
Units	<p>GPM Gallons per minute KLH Kiloliters per hour</p> <p>MGD Mega gal per day LPH Liters per hour</p> <p>CFS Cubic feet per second CMM Cubic meters per minute</p> <p>MLD Megaliters per day CFM Cubic feet per minute</p> <p>LPS Liters per second CFM Cubic feet per minute</p> <p>CMH Cubic meters per hour B5M Barrels per minute (55G)</p> <p>LPM Liters per minute B5H Barrels per hour (55G)</p> <p>GPH Gallons per hour B5D Barrels per day (55G)</p> <p>IGM Imperial gal per minute B4M Barrels per minute (42G)</p> <p>MI9 Miners inch (9G) B4H Barrels per hour (42G)</p> <p>MI1 Miners inch (11.22G) B4D Barrels per day (42G)</p> <p>APD Acre feet per day</p>	

FlowCom Digital Register Specification (cont.)

Totalizer Units	GAL	Gallons	AIN	Acre Inch
	CUF	Cubic Feet	TON	Ton (Short)
	AFT	Acre Feet	MM1	Miners Inch Minute (11.22G)
	CUM	Cubic Meters	MM9	Miners Inch Minute (9G)
	LIT	Liters	MH1	Miners Inch Hour (11.22G)
	MML	Megaliter	MD1	Miners Inch Day (11.22G)
	MTT	Metric Ton (KL)	MH9	Miners Inch Hour (9G)
	B31	Barrel (31G)	MD9	Miners Inch Day (9G)
	B42	Barrel (42G)	KGL	Kilo Gallons
	B46	Barrel (46G)	MGL	Mega Gallons
	B55	Barrel (55G)	IN3	Cubic Inch
	IMG	Imperial Gallon		
	Data Logger	Standard with all models, minimum of five years of data stored (4gb)		

Other Specifications

Options and Accessories	<ul style="list-style-type: none"> • Data Logger - included as standard with five years of data storage at default (12hr) interval. (Cable sold separately) • AC, DC, and battery powered available
--------------------------------	---

FlowCom Part Number Matrix

FC2							
Product Line							
McCrometer		00					
Water Specialties		01					
Assembly Component Options							
Conversion Kit (From Mechanical)		K					
Flowcom (FC100 to FC200) Upgrade Kit		R					
Flowcom (FC200) Replacement Kit		F					
Output Options							
No Outputs							
Open Collector Pulse		1					
4-20mA Analog		2					
4-20mA Analog and Open Collector Pulse		3					
Output Cable Options							
No Output Cables							
6 ft		C1					
15 ft		C2					
25 ft		C3					
50 ft		C4					
75 ft		C5					
100 ft		C6					
150 ft		C8					
Smart Output Protocol / Telemetry Options							
No AMI Outputs/Telemetry Options							
Sensus Protocol (6ft cable, Nicor Connector hardwired only)		SEN					
Itron 6 digit Protocol (6ft cable, Nicor Connector hardwired only)		IT6					
Itron 9 digit [100W] Protocol (6ft cable, Nicor Connector hardwired only)		IT9					
Neptune Protocol (6ft cable, Nicor Connector hardwired only)		NEP					
2 ft SmartTrax Standalone Unit ExactRead Cable		S02					
6 ft SmartTrax Standalone Unit ExactRead Cable		S06					
25 ft SmartTrax Standalone Unit ExactRead Cable		S25					
50 ft SmartTrax Standalone Unit ExactRead Cable		S50					
Register Remote and Extension Options							
Meter Mount (Standard)							
6 ft Cable Remote Mount (Flowcom only)		R06					
25 ft Cable Remote Mount (Flowcom only)		R25					
50 ft Cable Remote Mount (Flowcom only)		R50					
No Batteries, Battery Tray Options							
Includes Batteries (Standard)							
No Batteries (Alkaline Tray)		NBA					
No Batteries (Lithium Tray)		NBL					

FlowConnect Specifications

Communication

Network Type	Cellular	Satellite
Protocols	GSM/GPRS	Iridium
Operating Frequency (MHz)	824–849	1616-1626.5
	869–894	
	1850–1910	
	1930–1990	
	1710–1755	
Antenna	External Bulkhead Extension TNC Antenna 800/1800/1900 MHz	External Bulkhead Extension TNC Antenna 1,600 Mhz

Power

Batteries	Batteries can be replaced by user on-site Battery Only: 2 Primary D-Cells 3.6V 13Ah (Both batteries need to be replaced at the same time) Rechargeable: 1 Primary D-Cell 3.6V and 3 Secondary C-Cells, 1.2V in series
External Power	Requires Rechargeable Battery Configuration listed above. Recommended 9-12 VDC, 0-1000mA Max: 14.5 VDC (Power supply or solar panel)
Recommended Battery Replacement Interval	Battery Only: 3 years (Daily Report Interval) Rechargeable: 4 years

Environmental

Operating Temperature	- 30°C to 70°C (-22°F to 158°F)
Electrical / Mechanical Protection	All electrical components are grounded to fluid column and pipe. Manufactured in accordance with IP-67 Standards and ESD-safe
Environmental Protection	Ingress Protection (Dust Tight / Water Tight) to IP67 Vibration proof while operating: Validated Vibration and 20G Sinusoidal testing to JEDEC 22B103B Section 4.3, Table 3, Service Condition C, for all axis and 20G sin sweep 20 - 2,000Hz for all axis.
Tamper Protection	Factory installed tamper-evident wire lock system

FlowConnect Specifications (cont.)

Other Characteristics

Mounting	Top Plate compatible with any McCrometer Propeller or Water Specialties (Digital Register Only)
External Interface	Five-pin serial-USB cable
Flow Indicator	Digital Register or McPropeller Mechanical Register
Operating Temperature	- 30°C to 70°C (-22°F to 158°F)
Inputs	Two analog sensors, 1 pulse accumulator (for rain gauge)
Outputs	Mechanical Register: None Digital Register: 4-20 mA, Open Collector Pulse, Dry Contact Pulse, Optically Isolated Pulse (via 5- pin output cable)
Data Collection Method	Digital Register: Serial interface between FlowConnect and digital register allows FlowConnect to read totalizer and rate value directly. No pulse counting required and always a perfect match. Mechanical Register (McPropeller only): Pulse counter and high-low digital signal for forward-reverse pulses. Accuracy between meter and Web totalizer: ±0.25%
Data Storage	Capable of storing up to 1,000 reports in local memory

Accessories

Optional Protective Cover	Gray boot cover, p/n TOB065	
Serial Accessories	200.720.542 serial-USB cable	
Power Accessories	Rechargeable: 200.723.520 2.5W 220mA Solar Panel 200.733.522 5W 540 mA Solar Panel 200.720.523 115V Power Supply Battery Only: No Power Accessories	
Sensor Accessories	Adcon PA1 Cables - Pressure 10bar 500.000.120 - 16 ft. Cable 500.000.119 - 32 ft. Cable 200.733.048 - RGI Rain Gauge 200 200.720.510 - Y Cable 200.733.902 - A902 1/2/3 Cable	
Communication Accessories	Cellular	Satellite
	900.000.590 TNC Rigid Antenna (Included)	TOB039 Helical Antenna (Included)
	900.000.565 Directional Antenna	MCC-510-AI-A Extension Antenna, Magnet Mount
	900.000.567 Extension Antenna	

FlowConnect Dimensions

Dimensions

Network Type	Cellular	Satellite
Unit Enclosure Size	W x D x H	W x D x H
Non-Rechargeable	6.5" x 5.6" x 9.9"	6.5" x 5.6" x 9.8"
Rechargeable	6.5" x 6.1" x 9.9"	6.5" x 6.1" x 9.8"
Packaged Dimensions	11" x 11" x 11"	11" x 11" x 11"
Packaged Weight	6 lbs.	6 lbs.

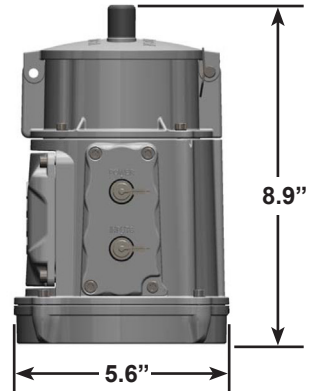
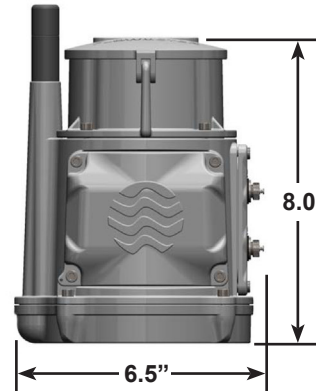
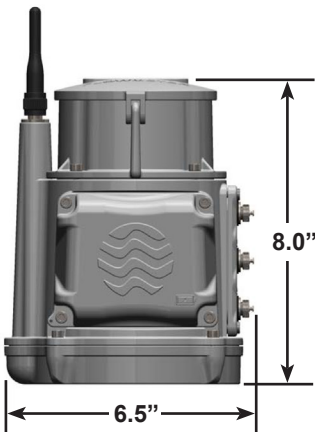
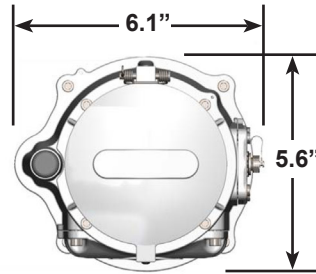
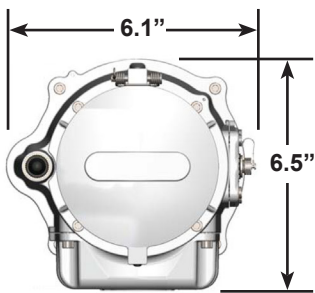



McCrometer, Inc.
3255 West Stetson Avenue
Hemet, CA 92545 USA
Tel: 951-652-6811
800-220-2279
Fax: 951-652-3078
customerservice@mccrometer.com
www.mccrometer.com