



FPI MAG 3000
FULL PROFILE INSERTION
ELECTROMAGNETIC FLOW METER
MODELS 394 AND 395 MAG METER SUBMITTAL

From

McCROMETER
3255 WEST STETSON AVENUE
HEMET, CA 92545

Phone (951) 652-6811
Toll Free (800) 220-2279
Fax (951) 652-3078

www.mccrometer.com

Date:

Project Name:	
Purchase Order No.:	
Date:	
Customer Name:	
Submitted By:	
Other Project Information:	

When completing this submittal package, it must also include the Mag Meter Part and Price Configurator, which is also an electronic document. A version without pricing can be downloaded from the McCrometer web site with the following link.

[Muni FPI Mag Part and Price Configurator](#)

The Mag Meter Part and Price Configurator is a macro-enabled Excel spreadsheet that contains multiple drop down fields for multiple product configurations. After it is filled out, save the spreadsheet under a different name and submit the file with the submittal package.

You can request a version of the Configurator with pricing by contacting McCrometer Customer Service or Inside Sales. Their contact information is on the McCrometer Web site.

PART NUMBER	DESCRIPTION	METER 1 QTY.	METER 2 QTY.	METER 3 QTY.
Standard Equipment				
Model 395	FPI Mag™ Meter Forward Flow			
	Standard meter			
	Hazardous location meter			
Model 394	FPI Mag™ Meter Bidirectional Flow			
	Standard meter			
	Hazardous location meter			
	ProComm Go Transmitter • Battery power standard • Two digital pulse outputs • Data logger			
<p>Notes on standard equipment on FPI Mag flow meters:</p> <ul style="list-style-type: none"> • Nominal pipe size in inches (4" to 138") • 2" stainless steel full port ball valve with 2 x close stainless steel nipple • Quick Connect Cable Connector (IP68) • Submersible sensor cable, 25 feet • Compression seal • Set of installation rods • Set of retaining rods • Instruction manual • 3M fusion bonded epoxy protective coating on probe 				
Sensor Options				
	Additional sensor cable: Specified total length in feet (leave blank for none)			
Special	Compression Gland Seals (instead of Quick Connects at sensor)			
75031/75032	Insertion Tool			
170007101	Stainless Steel Tag			
Transmitter Options				
	Power Options	10 to 35 VDC		
		100 to 240 VAC		
	Communications Options (select all that apply)	SmartTrax		
		AMI Smart Output (Sensus, Itron 6, Itron 9)		
	Output Option	4-20mA (passive)		



IMPORTANT: The MINIMUM port inside diameter for all installation valves is 1-7/8" (48mm).

Project Notes

Meter 1:

Meter 2:

Meter 3:

Contents

FPI Mag 3000	5
Suggested Specifications	5
Product Specifications.....	8
Part Number Matrix	11
FPI Mag 3000 Sensor Parts.....	13
ProComm Go Transmitter	14
Transmitter Specifications	14
Transmitter Dimensions	16
Cable Connections from Sensor.....	17
Battery Installation and Connection.....	20

Suggested Specifications

PART 1 - GENERAL

1.1 SCOPE

This section describes the requirements for an electromagnetic insertion flow meter and microprocessor-based signal transmitter. Under this item, the contractor shall furnish and install the insertion mag meter equipment and accessories as indicated on the plans and as herein specified.

1.1 SUBMITTALS

The following information shall be included in the submittal for this section:

1. Data sheets and catalog literature for the 395 or 394 Insertion Mag meter and the microprocessor-based signal transmitter
2. Connection diagrams for equipment wiring.
3. List of spare parts and optional equipment.

PART 2 - PRODUCTS

2.1 ELECTROMAGNETIC INSERTION FLOWMETER (FPI MAGMETER)

The electromagnetic insertion flow meter shall consist of a flow sensor based on Faraday's Law of Electromagnetic Induction and microprocessor-based signal transmitter.

A. Sensor:

1. Operating principle: Utilizing Faraday's Law of Electromagnetic Induction, the flow of a conductive liquid around the sensor induces an electrical voltage that is proportional to the velocity of the flow.
2. Construction: The sensor material shall be constructed of 316 Stainless Steel and coated with NSF 61 certified approved epoxy coating.
3. Hastelloy Electrodes (Optional) shall be used when corrosive fluid is present.
4. Sensor operating Temp: +14° to +140° F @ 250 PSI
5. Electronics operating temperature (Transmitter): -4° to +140° F
6. Size: 4" to 138" diameter (see instrument schedule)
7. Installation hardware shall include a Stainless Steel 2" full ported valve with a stainless-steel nipple.
8. Submergence:
 - a. The sensor shall be NEMA 6P or IP68 rated to be permanently submerged up to 6 feet.
 - b. The sensor shall be NEMA 6P or IP68 rated to be permanently submerged up to 30 feet (option with IP68 rated strain relief connection only).

B. Transmitter:

1. Electronic Enclosure: Shall be a NEMA 4X, IP67 rated enclosure.
2. Transmitter/display: Background illumination with alphanumeric 8-line graphical backlit LCD display with 6-keyouch programming to indicate flow rate, totalized values, settings, and faults.
3. Power supply:
 - a. 100/240 VAC
 - b. 10-35 VDC (option)
 - c. Battery (option)

Suggested Specifications

4. Operating temperature: -4 to +140 degrees F.
5. Outputs:
 - a. 4-20 mA (0-21mA).
 - b. Two separate digital programmable outputs:
 - 1) Open collector transistor usable for pulse
 - 2) Frequency and alarm settings
6. Communications-Optional:
 - a. SmartTrax
 - b. AMI Smart Output (Sensus, Itron 6, Itron 9).
 - 1) Sensus
 - 2) Itron 6 digit
 - 3) Itron 9 digit
 - 4) Neptune
7. Transmitter Self Diagnostics
8. Manufacturer shall provide an optional Hazardous Location certified model. Certified by MET to UL 6100-1 and MET C22.2 No. 61010-1-04
 - a. Class I, Division 2, Groups A-D, T5
 - b. Class I, Zone 2, IIC T5
9. Sensor and signal transmitter performance:
 - a. Flow Range: .2 FPS to 32 FPS for accuracies stated below.
 - b. Accuracy:
 - 1) ProComm Go Electronics : $\pm 1\%$ of measured value ± 0.006 ft/s (± 0.0018 m/s)
 - 2) Reverse Flow: $\pm 1\%$ of measured value ± 0.006 ft/s (± 0.0018 m/s)
 - c. Cable Length: Remote Mount
 - 1) AC or DC Power: Up to 500'/152.4m
 - d. Manufacturer shall offer optional Quick Connect cabling for remote mounted installations.
 - e. Repeatability: $\pm 0.05\%$ or ± 0.0008 ft/s (± 0.25 mm/s), whichever is greater
 - f. Conductivity: Minimum 5 μ s/cm
 - g. Optional meter mounted transmitter.
 - h. Bi-directional flow capabilities (optional)
 - i. Power & Signal Cabling: The power and signal between the transmitter and sensor are combined in a single cable.
 - j. Flow Direction Measurement: Forward and reverse flow indication and forward, reverse, net totalization is available.

2.2 THE ELECTROMAGNETIC INSERTION FLOW METER SHALL BE FPI MAG 3000 395 FOR FORWARD FLOW, OR 394 BI-DIRECTIONAL FULL PROFILE INSERTION MAG METER OR EQUAL.

2.3 **SPARE PARTS**

- A. Spare parts for the equipment shall include the following, unless otherwise noted:
 1. Extra operation manuals as required.

Suggested Specifications

2.4 OPERATOR FUNCTIONS

- A. Calibration
 - 1. Each flow sensor shall have wet flow calibration of the complete meter flow element and its signal transmitter. The calibration facilities must be traceable to the National Institute of Standards and Technology (N.I.S.T). All the calibration information and factory settings matching the sensor shall be stored in an integrally mounted memory unit. The memory unit shall store sensor calibration data and signal transmitter settings for the lifetime of the product. At initial commissioning, the flow meter commences measurement without any initial programming. Any customer specified settings are downloaded to the memory unit. Should the signal transmitter need to be replaced, the new signal transmitter will upload all previous settings and resume measurement without any need for reprogramming or rewiring.
 - 2. Manufacturer shall provide a calibrated meter set which includes the sensor element, the cabling and the transmitter.
 - 3. An N.I.S.T. certificate of calibration shall accompany each flow element.

PART 3 - PART 3 - EXECUTION

3.1 INSTALLATION

- A. Follow manufacturer's recommendation for the minimum upstream and downstream installation requirements for the flow element.
- B. Wiring between flow element and remote mounted signal transmitters shall use cable type and procedures as per the manufacturers' recommendations.

3.2 MANUFACTURER'S ASSISTANCE

- A. Warranty
 - 1. The manufacturer of the electromagnetic flow meter shall provide a two-year warranty that the equipment shall be free from defects in design, workmanship, or materials. Extended warranties up to five years shall be available for additional cost.
 - 2. The manufacturer of the electromagnetic flow meter shall provide a Lifetime Guarantee on the flow element Ultra Liner fusion bonded epoxy liner.
 - 3. In the event a component fails to perform as specified or is proven defective in service during the guarantee period, the manufacturer shall promptly repair or replace the defective part at no cost to the owner.

Product Specifications

The full pipe averaging flow meter comes complete with Mounting Hardware, AC Converter with Dual 4-20mA output, 25 Feet of Dual Submersible Cables with quick connects at sensor, Stainless Steel Body, 316 Stainless Steel Electrodes, NSF Approved Fusion Bonded Epoxy Coating, 2" Stainless Steel Ball Valve (minimum of 1-7/8" port I.D.), 2" x Close Stainless Steel Nipple, 2-Year Warranty.

Physical Specifications

Measurement	Electromagnetic
Directionality	Forward and reverse
Pipe Sizes	Up to 138"
Body Style	Full profile insertion
Materials	<ul style="list-style-type: none"> Stainless steel body 316 stainless steel electrodes NSF approved fusion bonded epoxy coating 2" stainless steel ball valve (minimum of 1-7/8" port I.D.) 2" x close stainless steel nipple
Coating	Fusion bonded epoxy (NSF 61 approved) coated 316 stainless steel
Electrodes	316 Stainless Steel, Hastelloy optional
Electrical Connections	Quick Connect
Electronics	ProComm GO electronics
Electronics Mount	Remote mount only
Sensor Cable Lengths	<ul style="list-style-type: none"> Standard: 25'/7.6 m McCrometer supplied submersible cable with each remote mount unit. Optional: Up to 500'/152.4 m, or 25'/7.6 m max for battery powered. Quick connect: Available in standard cable lengths: Feet: 25, 50, 75, 100, 125, 150, 175, 200, 500 Meters: 7.6, 15.25, 22.5, 30.5, 38.1, 45.75, 53.3, 61, 152.4 Custom quick connect cable lengths at additional cost.
Insertion Hardware	316 Stainless Steel
Compression Seal	Silicone Rubber

Performance and Operational Specifications

Measurement Method	Volumetric flow in filled flow conduits 4" (100 mm) to 138" (3,500 mm) utilizing insertable electromagnetic averaging sensor. Flow indication in English Standard or Metric units.
Direction Measurement	<ul style="list-style-type: none"> 395 sensor: Forward flow measurement and reverse flow indication 394 sensor: Bidirectional flow measurement
Operating Temperature	-10 to 60°C (14 to 140°F) up to 250 PSI
Storage Temperature	-15 to 60°C (5 to 140° F) Note regarding storage: During freezing conditions and when meter is not in use, sensor must be removed from pipe and stored in dry conditions. Note: Damage to the sensor caused by allowing the sensor freeze in the pipe is not covered by the warranty.
IP Rating	<ul style="list-style-type: none"> Standard model: Quick Connect (IP68) HL model: Quick Connect (IP67)
Sensor Submersibility Depth	With standard quick connect: 9 m (30 ft.)

Product Specifications

Velocity Range	See following pages flow velocity ranges by line size for each type of electronics.
Calibrated accuracy for forward and bidirectional sensors	<ul style="list-style-type: none"> • ProComm Go Electronics : ±1% of measured value ±0.006 ft/s (±0.0018 m/s) • Reverse Flow: ±1% of measured value ±0.006 ft/s (±0.0018 m/s)
Linearity	0.3% of Range
Repeatability	0.2% of Reading
Pipe Run Requirements	Pipe run requirements for the FPI Mag sensor can vary, depending on the disturbances in the pipe run. See FPI Mag flow meter manual 30127-05, step 3 of the installation procedure for a table of upstream and downstream straight-pipe run recommendations.

Other Specifications

Certifications and Approvals	<p>Standard model:</p> <ul style="list-style-type: none"> • ISO 9001:2015 certified quality management system • Certified by MET to UL 61010-1 • Certified to NSF / ANSI Standards* <p>HL Model:</p> <ul style="list-style-type: none"> • ISO 9001:2015 certified quality management system • Certified by MET to UL 61010-1 and MET C22.2 No. 61010-1-04 <ul style="list-style-type: none"> • Class I, Division 2, Groups A-D, T5 • Class I, Zone 2, IIC T5 • Certified to NSF / ANSI Standards*
System Options	<ul style="list-style-type: none"> • Hastelloy electrodes • Annual verification / calibration • Stainless steel ID tag
Meter Options and Accessories	<ul style="list-style-type: none"> • Sensor insertion tool • Extension to hardware clearance • Additional sensor cable up to 475' (500' max for model 395 and 200' max for model 394)
Warranty	2 years

* Certified by IAPMO R&T to NSF/ANSI 61 for material safety and NSF/ANSI 372 for low lead content.

Note regarding cable length: McCrometer recommends minimizing cable length. Electromagnetic flow meters may have unfavorable signal strength to noise ratio in electrically noisy environments. Longer lengths of cable increase the likelihood of interference. In those cases where the meter's signal must be transmitted a long distance, or where the environment may be particularly noisy, we suggest using the converter's analog output(s) that allows locating the transmitter as close as possible to the metering location.

Product Specifications

Flow Meter Pipe Sizes and Flow Ranges with ProComm Max Transmitter

Imperial Units

Pipe Size (Nominal)	Pipe ID Range		Flow Ranges (GPM Standard)		Standard Program Defaults ¹	Minimum Clearance Required During Installation ²	Velocity Range ³ (f/s)	
	Min Pipe ID	Max Pipe ID	Min (GPM) ¹	Max (GPM) ¹	20mA (GPM)			
S = Standard (Available in 395 models Pipe Sizes 4" - 24" as shown in table below) C = Custom (Available in all 394 and 395 models Pipe Sizes 4" - 138") Standard Length Hardware and Installation Clearance Dimensions are based on a 4" Maximum Height Coupling and Pipe Schedule Standard								
4"	3.74	4.99	12	1280	1280	51"	0.3 - 32	
6"	5.00	7.24	26	2800	2800	51"	0.3 - 32	
8"	7.25	9.24	47	5000	5000	55"	0.3 - 32	
10"	9.25	11.24	80	8000	8000	55"	0.3 - 32	
12"	11.25	12.99	110	11000	11000	59"	0.3 - 32	
14"	13.00	14.99	150	15000	15000	59"	0.3 - 32	
16"	15.00	16.75	190	20000	20000	59"	0.3 - 32	
18"	16.76	18.80	240	26000	26000	63"	0.3 - 32	
20"	18.81	22.74	300	28000	28000	63"	0.3 - 28	
24"	22.75	24.99	410	33000	33000	67"	0.3 - 23	
30"	25.00	33.99	600	44000	44000	71.25"	0.3 - 20	
36"	34.00	39.99	1000	48000	48000	77.25"	0.3 - 15	
42"	40.00	45.99	1300	56000	56000	83.25"	0.3 - 13	
48"	46.00	51.99	1700	62000	62000	89.25"	0.3 - 11	
54"	52.00	57.99	2200	79000	79000	95.25"	0.3 - 11	
60"	58.00	63.99	2600	97000	97000	101.25"	0.3 - 11	
66"	64.00	69.99	3200	106000	106000	107.25"	0.3 - 10	
72"	70.00	75.99	3800	127000	127000	113.25"	0.3 - 10	
78"-128"	76.00	138.00	Available - Call Factory at 1-800-220-2279					

¹ Default totalizer units measured as KGAL.

² Hardware clearance after installation for all sizes is 28".

³ Flow temperature range -10° to 60° C (14° to 140° F) up to 250 PSI, max pressure is 250 psi.

Required Information

At the time of ordering, please be prepared to provide the following information:

1. Pipe ID and Pipe OD
2. Unit of Measure (US Gallons is Default)
3. Maximum pressure
4. FPI Specification Data Sheet for custom length sensors

Consult factory if any chemicals are in use.

Part Number Matrix

FP339		-																		
Single or Bidirectional Flow																				
Bidirectional Flow		4																		
Single Forward Flow		5																		
Standard or Customer Length Sensor																				
Standard Length Sensor		S																		
Custom Length Sensor		C																		
Nominal Line Size																				
4 in		04																		
6 in		06																		
8 in		08																		
10 in		10																		
12 in		12																		
14 in		14																		
16 in		16																		
18 in		18																		
20 in		20																		
24 in		24																		
30 in		30																		
36 in		36																		
42 in		42																		
48 in		48																		
54 in		54																		
60 in		60																		
66 in		66																		
72 in		72																		
78 in		78																		
84 in		84																		
90 in		90																		
96 in		96																		
100 in		H0																		
110 in		H1																		
120 in		H2																		
130 in		H3																		
Sensor Length Options																				
20" Sensor Length		020																		
21" Sensor Length		021																		
Each nominal Inch Length		XXX																		
175" Sensor Length		175																		
Electrode Material Options																				
S316 Stainless Steel (Standard)		S																		
Hastelloy		H																		
Ball Valve Options																				
2" NPT		N																		
2" BSPT		B																		
No Valve 2" NPT		X																		
No Valve 2" BSPT		Y																		
Remote Mount Cable Connector Options																				
25 ft. Quick Connect		Q																		

FPI Mag 3000 Sensor Parts

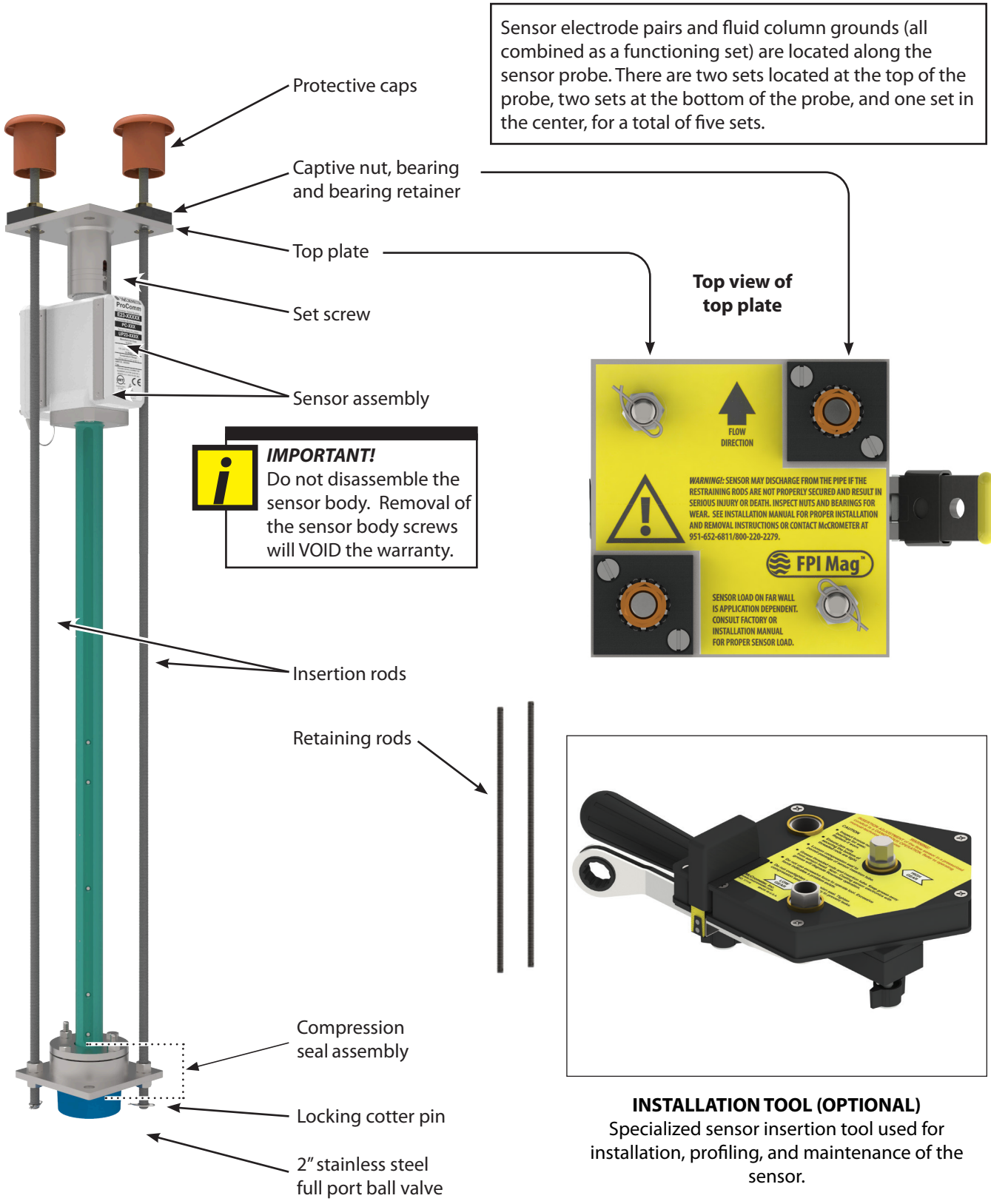

Transmitter Specifications

Physical Specifications

Electronic Housing	Diecast aluminum, powder coated enclosure w/ tamper resistant seal, 6½" x 6½" x 43/8" tall
Transmitter Dimensions	See "Dimensions" section for meter mount and remote mount transmitter dimensions.
Power	Battery: Standard: three 3.6V lithium-thionyl chloride (Li-SOCl ₂) D size batteries with two AA backup batteries AC Power: 100-240VAC/45-66Hz (4W) DC Power: Linear power supply 10-35VDC (4 W)
Electrical Connections	<ul style="list-style-type: none"> Optional shielded cable for 10-32VDC/4-20 mA output Optional shielded cable for pulse out

Performance and Operational Specifications

Battery Life	Five-year expected battery life, five-year battery warranty
Location	Indoor or outdoor use
Altitude	Operating: 2000 meters Storage: 12,000 meters
Operating Temperature	-4° to 140° F (-20° to 60° C)
Storage Temperature	-4° to 140° F (-20° to 60° C)
Relative Humidity	0% to 100%
IP Rating	IP67 Die cast aluminum transmitter
Outputs	Digital output: Digital pulse (open collector) output for volumetric - Two isolated digital pulse (open collector) outputs for volumetric - AMI output Analog output: 4-20mA: Galvanically Isolated, 16 Bit resolution. All power configurations (including battery). Note: 9-30 VDC loop power required (not supplied via transmitter)

Display and Measurement

Display	<ul style="list-style-type: none"> 2-Line LCD display (no backlight) Non-volatile memory Anti-reverse totalizer (standard) Total (to 9 digits of precision) 	<ul style="list-style-type: none"> Flow rate and velocity (to 5 digits of precision) Two alarms: low battery and empty pipe (optional) Opening lid activates display 																																																
Digits	5 Rate, 9 Total																																																	
Units	<table border="0"> <tr> <td>GPM</td> <td>Gallons per minute</td> <td>IGM</td> <td>Imperial gal per minute</td> <td>CFM</td> <td>Cubic feet per minute</td> </tr> <tr> <td>MGD</td> <td>Mega gal per day</td> <td>MI9</td> <td>Miners inch (9G)</td> <td>B5M</td> <td>Barrels per minute (55G)</td> </tr> <tr> <td>CFS</td> <td>Cubic feet per second</td> <td>MI1</td> <td>Miners inch (11.22G)</td> <td>B5H</td> <td>Barrels per hour (55G)</td> </tr> <tr> <td>MLD</td> <td>Megaliters per day</td> <td>APD</td> <td>Acre feet per day</td> <td>B5D</td> <td>Barrels per day (55G)</td> </tr> <tr> <td>LPS</td> <td>Liters per second</td> <td>KLH</td> <td>Kiloliters per hour</td> <td>B4M</td> <td>Barrels per minute (42G)</td> </tr> <tr> <td>CMH</td> <td>Cubic meters per hour</td> <td>LPH</td> <td>Liters per hour</td> <td>B4H</td> <td>Barrels per hour (42G)</td> </tr> <tr> <td>LPM</td> <td>Liters per minute</td> <td>CMM</td> <td>Cubic meters per minute</td> <td>B4D</td> <td>Barrels per day (42G)</td> </tr> <tr> <td>GPH</td> <td>Gallons per hour</td> <td>CFM</td> <td>Cubic feet per minute</td> <td></td> <td></td> </tr> </table>		GPM	Gallons per minute	IGM	Imperial gal per minute	CFM	Cubic feet per minute	MGD	Mega gal per day	MI9	Miners inch (9G)	B5M	Barrels per minute (55G)	CFS	Cubic feet per second	MI1	Miners inch (11.22G)	B5H	Barrels per hour (55G)	MLD	Megaliters per day	APD	Acre feet per day	B5D	Barrels per day (55G)	LPS	Liters per second	KLH	Kiloliters per hour	B4M	Barrels per minute (42G)	CMH	Cubic meters per hour	LPH	Liters per hour	B4H	Barrels per hour (42G)	LPM	Liters per minute	CMM	Cubic meters per minute	B4D	Barrels per day (42G)	GPH	Gallons per hour	CFM	Cubic feet per minute		
GPM	Gallons per minute	IGM	Imperial gal per minute	CFM	Cubic feet per minute																																													
MGD	Mega gal per day	MI9	Miners inch (9G)	B5M	Barrels per minute (55G)																																													
CFS	Cubic feet per second	MI1	Miners inch (11.22G)	B5H	Barrels per hour (55G)																																													
MLD	Megaliters per day	APD	Acre feet per day	B5D	Barrels per day (55G)																																													
LPS	Liters per second	KLH	Kiloliters per hour	B4M	Barrels per minute (42G)																																													
CMH	Cubic meters per hour	LPH	Liters per hour	B4H	Barrels per hour (42G)																																													
LPM	Liters per minute	CMM	Cubic meters per minute	B4D	Barrels per day (42G)																																													
GPH	Gallons per hour	CFM	Cubic feet per minute																																															

Transmitter Specifications



Display and Measurement (cont.)

Totalizer Units	GAL	Gallons	B42	Barrel (42G)	MH1	Miners Inch Hour (11.22G)
	CUF	Cubic Feet	B46	Barrel (46G)	MD1	Miners Inch Day (11.22G)
	AFT	Acre Feet	B55	Barrel (55G)	MH9	Miners Inch Hour (9G)
	CUM	Cubic Meters	IMG	Imperial Gallon	MD9	Miners Inch Day (9G)
	LIT	Liters	AIN	Acre Inch	KGL	Kilo Gallons
	MML	Megaliter	TON	Ton (Short)	MGL	Mega Gallons
	MTT	Metric Ton (KL)	MM1	Miners Inch Minute (11.22G)	IN3	Cubic Inch
	B31	Barrel (31G)	MM9	Miners Inch Minute (9G)		
Data Logger	Standard with all models, minimum of five years of data stored					

Other Specifications

Options and Accessories	<ul style="list-style-type: none"> Data Logger - included as standard with five years of data storage at default (12hr) interval. (Cable sold separately) AC, DC, and battery powered with battery backup powered available
Safety	<ul style="list-style-type: none"> IEC 61010-1, Pollution Degree II Overvoltage protection Category III

Certifications

Standard Model	<ul style="list-style-type: none"> ISO 9001:2015 certified quality management system CE Certified by MET to UL 61010-1 	  
HL Model	<ul style="list-style-type: none"> ISO 9001:2015 certified quality management system CE Certified by MET to UL 61010-1 and MET C22.2 No. 61010-1-04 <ul style="list-style-type: none"> Class I, Division 2, Groups A B C D, T4 Class I, Zone 2, IIC T4 <p><i>Note: ProComm GO with SmartTrax On Board is not available for hazardous locations.</i></p>	

Transmitter Dimensions

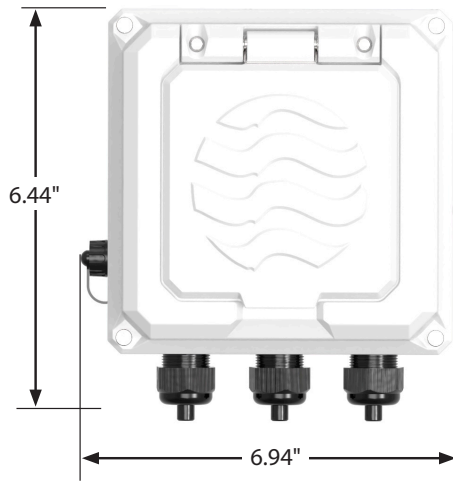

Meter mount converter

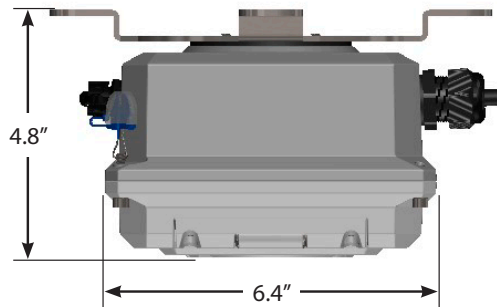
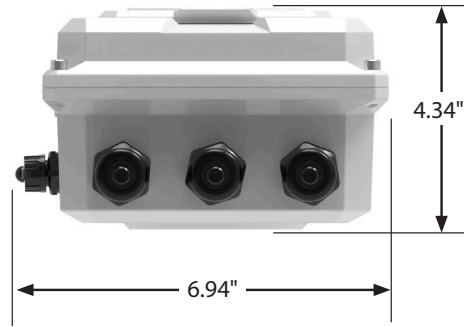

Remote mount converter

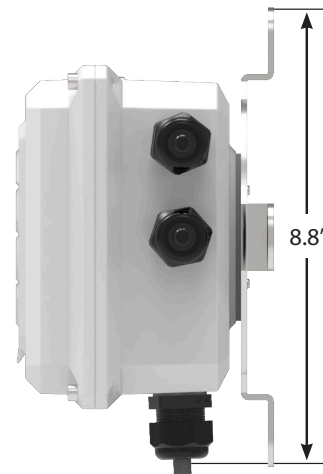
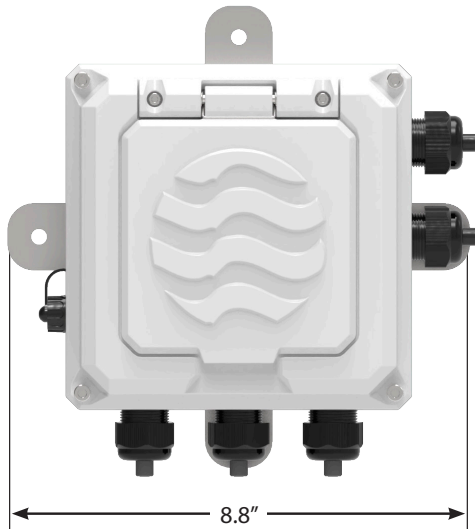

Cable Connections from Sensor

Example Remote Mount Configuration

After installing the sensor, mount the converter and connect the cable to the meter's junction box and the converter's external connection. Figure 4 below shows an example of a remote mount installation with an optional Smart Output connection.

You will need to prepare the location where you will install the remote converter. The location cannot be further from the flow meter than the length of the 25' cable. This must be planned in advance because **the cable cannot be lengthened**. Doing so will alter the calibration accuracy between the meter and the converter and void the warranty.

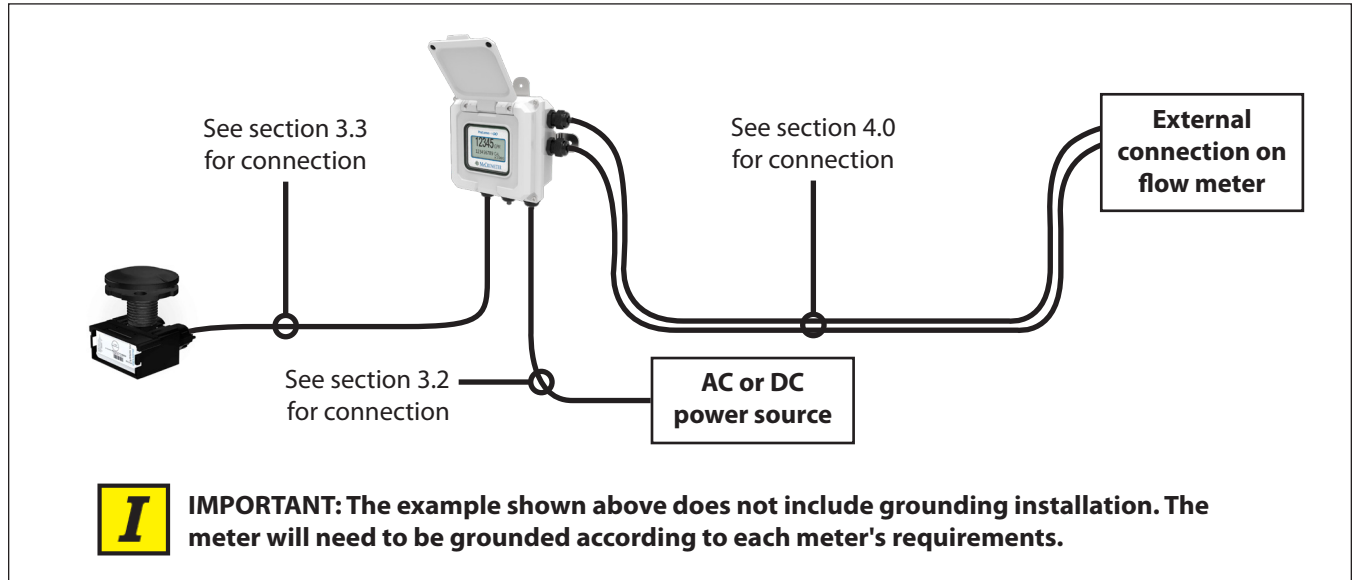

Cable Connections from Sensor

3.1 Terminal Block Diagram and Grounding Lug

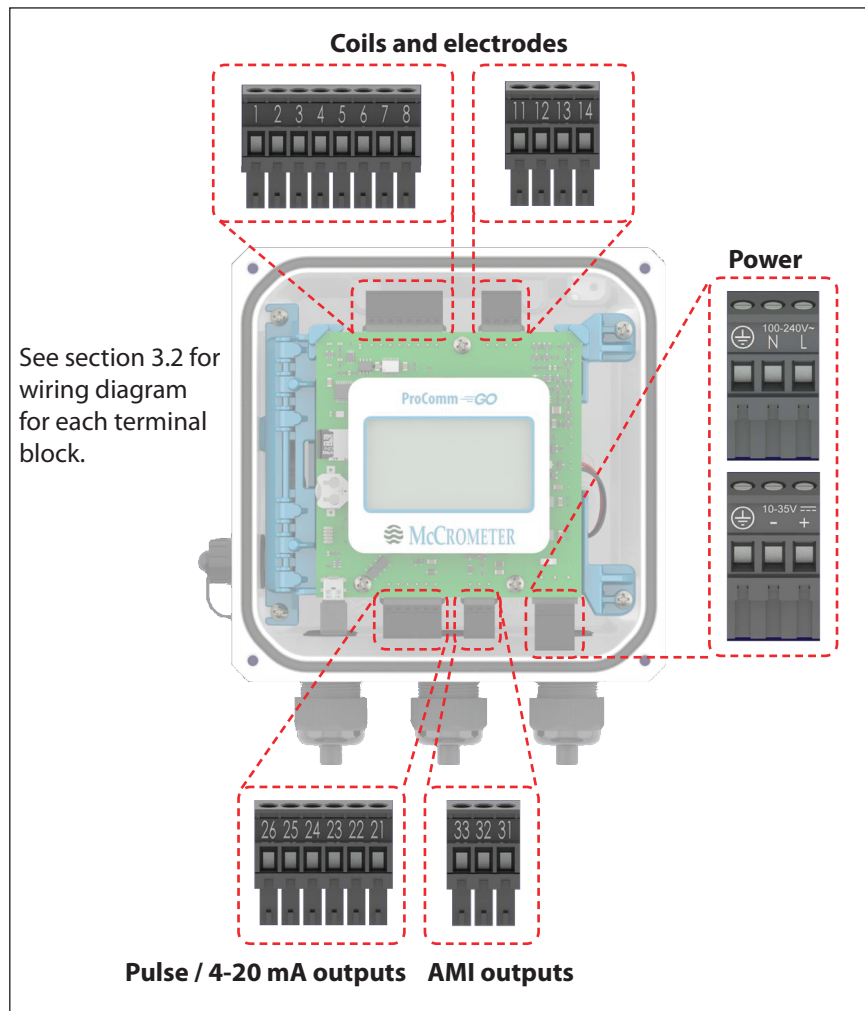

Figure 12. Terminal blocks

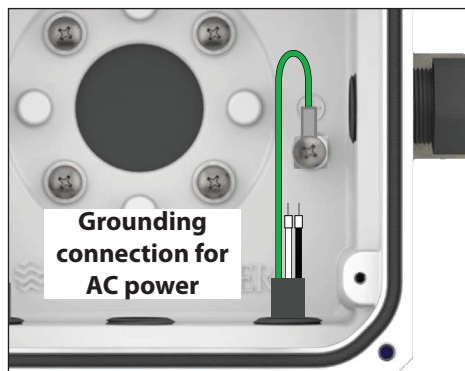
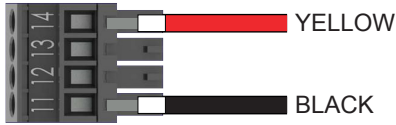

Figure 13. Grounding lug

Cable Connections from Sensor

TERMINAL BLOCK ASSIGNMENTS

Coils Harness



Terminal	Port	Wire Color
11	4	Black
14	4	Red

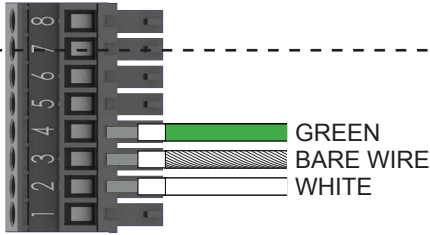

Electrodes Harness

Terminal	Port	Wire Color
2	5	White
3	5	Bare wire
4	5	Green

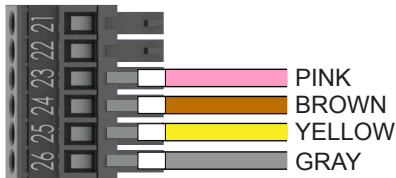

Pulse Output Harness

Terminal	Port	Wire Color
23	1	Pink
24	1	Brown
25	1	Yellow
26	1	Gray

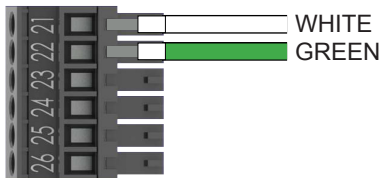

4-20 mA Output Harness

Terminal	Port	Wire Color
21	1	White
22	1	Green

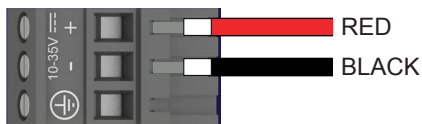

DC Power Harness

Terminal	Port	Wire Color
Positive	3	Red
Negative	3	Black



AC Power Harness

Terminal	Port	Wire Color
Load	3	Black
Neutral	3	White
Chassis lug	3	Green

ATTACHES TO CHASSIS LUG  GREEN

To complete AC power connection, connect green grounding lug to chassis as shown on previous page.

Battery Installation and Connection

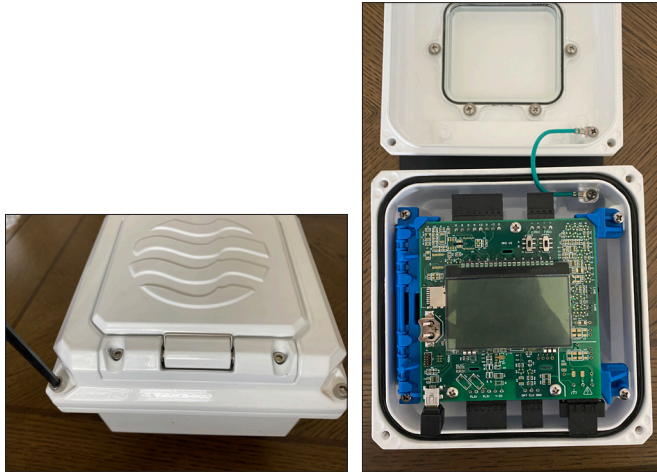

Large battery pack

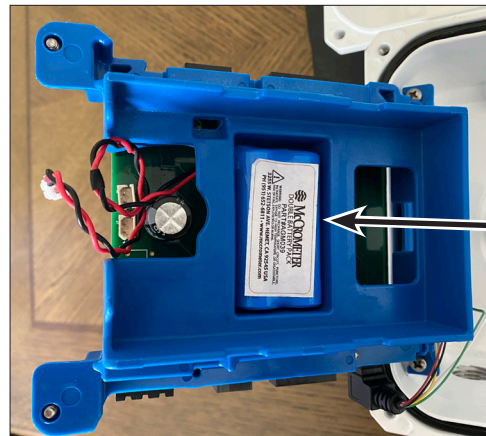

Small battery pack





McCrometer, Inc.
3255 West Stetson Avenue
Hemet, CA 92545 USA
Tel: 951-652-6811
800-220-2279
Fax: 951-652-3078
customerservice@mccrometer.com
www.mccrometer.com